

ALUMINCO[®]
ALUMINIUM BUILDING SYSTEMS



**FUSION
LINE**



TECHNICAL GUIDE



CONTENTS



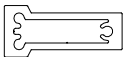
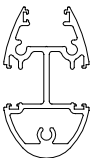
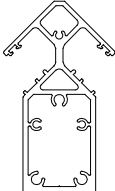

FUSION LINE: List of profiles, moments of inertia & resistance	3
FUSION LINE: List of profiles 1:1	9
LineaV	21
LineaV Balustrades: Top Mount	22
LineaV Top mount Ground fixing guide	39
LineaV Balustrades: Side Mount	59
LineaV Side mount Ground fixing guide	70
LineaV Fences	79
LineaV Fences Ground fixing guide	91
LineaV Profiles, Accessories	94
Orbit	101
Orbit 1 Assembly	102
Orbit 1 Ground fixing guide	110
Orbit 2 Assembly	114
Orbit 2 Ground fixing guide	123
Οδηγίες συγκράτησης του υαλοπίνακα στους τύπους των Orbit / Guidelines for glass panel support in Orbit types	127
Orbit Profiles & Accessories	128
Elxis	137
Elxis Assembly	138
Elxis Profiles & Accessories	145
Synthesis	150
Synthesis Assembly	151
Synthesis Ground fixing guide	162
Synthesis Profiles & Accessories	169
Πάκτωση των πελμάτων στο μπετόν (ελάχιστες απαιτήσεις) Ground anchoring of support feet (minimum requirements)	174
Σύνδεση κουπαστών στον τοίχο με τα εξαρτήματά τους / Wall fixing Fusion rail tops with their accessories	176
Συναρμολόγηση τυπικού πέλματος FUSION / FUSION Typical footplate assembly	177
Τοποθέτηση στο μπετόν FSN-105 με Πείρο Αγκύρωσης 4167 / FSN-105 Ground Fixing with Anchor Pin 4167	177
Αγκύρια στερέωσης / Concrete anchors	178
REQUIRED TOOLS	179

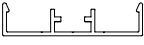
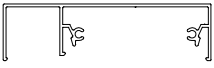
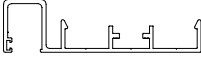

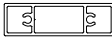
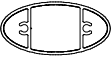
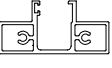

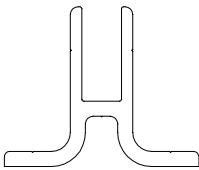

A photograph of a modern building's balcony. The balcony features a railing made of vertical, dark-colored slats. In the background, a city skyline is visible through the railing. To the right, a green wall with a grid pattern is partially visible, with some greenery growing on it. The overall scene is brightly lit, suggesting daytime.

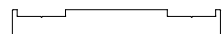
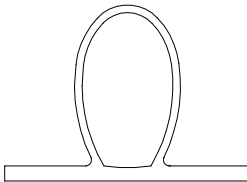

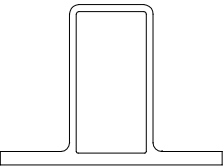
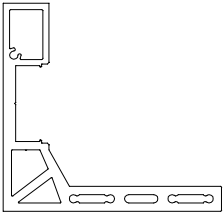
**FUSION LINE:
List of profiles,
moments
of inertia &
resistance**

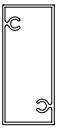
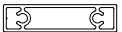
Κωδικός Code	Σχήμα Shape	Y X	Βάρος Weight gr/m	Μήκος Length m	Δέμα Pack	Ροπή Αδρανείας Moment of inertia cm ⁴		Ροπή αντιστάσεως Moment of resistance cm ³		Περιγραφή Description
						lx	ly	Wx	Wy	
FSN-100			1442	6	-	lx	0,86	Wx	1,44	Κολώνα Post Profile
						ly	21,20	Wy	6,62	
FSN-101			1980	6	-	lx	4,78	Wx	3,41	Κολώνα Post Profile
						ly	35,6	Wy	10,44	
FSN-102			2384	6	-	lx	49,97	Wx	11,60	Κολώνα Post Profile
						ly	14,77	Wy	6,56	
FSN-103			2367	6	-	lx	65,95	Wx	14,71	Κολώνα Post Profile
						ly	17,22	Wy	8,61	
FSN-104			3118	6	-	lx	125,88	Wx	22,32	Κολώνα Post Profile
						ly	23,74	Wy	7,73	
FSN-105			2367	6	-	lx	8,48	Wx	6,06	Κολώνα Post Profile
						ly	40,18	Wy	12,55	
FSN-221			754	6	-	lx	1,9	Wx	1,00	Καπάκι οδηγού CLS-201 Cover for guide CLS-201
						ly	27,2	Wy	6,80	
FSN-222			736	6	-	lx	2,0	Wx	1,13	Καπάκι οδηγού CLS-201 Cover for guide CLS-201
						ly	26,8	Wy	6,00	

Κωδικός Code	Σχήμα Shape	Y X	Βάρος Weight gr/m	Μήκος Length m	Δέμα Pack	Ροπή Αδρανείας Moment of inertia cm ⁴		Ροπή αντιστάσεως Moment of resistance cm ³		Περιγραφή Description
						lx	ly	Wx	Wy	
CLS-201			757	6	-	lx	0,66	Wx	0,52	Οδηγός Guide
						ly	16,01	Wy	4,33	
FSN-223			1006	6	-	lx	3,03	Wx	1,45	Οδηγός Guide
						ly	55,45	Wy	10,05	
FSN-203			1260	6	-	lx	3,63	Wx	1,90	Οδηγός Guide
						ly	51,66	Wy	8,76	
FSN-300			607	6	-	lx	2,07	Wx	1,46	Οδηγός Guide
						ly	2,91	Wy	1,64	
FSN-301			607	6	-	lx	1,69	Wx	0,93	Οδηγός Guide
						ly	2,91	Wy	1,64	
FSN-302			781	6	-	lx	1,21	Wx	1,42	Εσωτερικό προφίλ Internal Profile
						ly	9,89	Wy	3,41	
FSN-304			804	6	-	lx	2,34	Wx	1,68	Εσωτερικό προφίλ Internal Profile
						ly	8,73	Wy	3,01	
FSN-303			976	6	-	lx	2,22	Wx	1,23	Οδηγός Guide
						ly	10,54	Wy	3,62	

Κωδικός Code	Σχήμα Shape	Y X	Βάρος Weight gr/m	Μήκος Length m	Δέμα Pack	Ροπή Αδρανείας Moment of inertia cm ⁴		Ροπή αντιστάσεως Moment of resistance cm ³		Περιγραφή Description
						lx	ly	Wx	Wy	
FSN-306			857	6	-	lx	2,21	Wx	1,48	Οδηγός Guide
						ly	8,62	Wy	2,96	
FSN-307			475	6	-	lx	1,12	Wx	0,68	Οδηγός Guide
						ly	1,28	Wy	1,15	
FSN-901			1931	6	-	lx	7,98	Wx	3,64	Προφίλ Στηριξης Οδηγού Τζαμιού Support Profile Glass Panel Guide
						ly	2,74	Wy	2,54	
FSN-903			4717	6	-	lx	107,07	Wx	19,36	Προφίλ Εξωτερικής Στηριξης Κολωνας FSN-101 External Fixation Profile for FSN-101
						ly	88,80	Wy	17,24	
FSN-904			3005	6	-	lx	5,70	Wx	2,11	Προφίλ Στηριξης σε τοίχο FSN-102 Wall Support Profile for FSN-102
						ly	107,94	Wy	18	
FSN-907			4938	6	-	lx	3,28	Wx	4,21	Πέλμα Footplate
						ly	239,16	Wy	35,96	
FSN-906			3956	6	-	lx	2,40	Wx	2,92	Πέλμα Footplate
						ly	136,23	Wy	24,77	
FSN-909			4907	6	-	lx	164,40	Wx	24,32	Προφίλ Εξωτερικής Στηριξης Κολωνας FSN-102 External Fixation Profile for FSN-102
						ly	181,30	Wy	27,90	

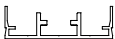
Κωδικός Code	Σχήμα Shape	Y X	Βάρος Weight gr/m	Μήκος Length m	Δέμα Pack	Ροπή Αδρανείας Moment of inertia cm ⁴		Ροπή αντιστάσεως Moment of resistance cm ³		Περιγραφή Description
						lx	ly	Wx	Wy	
FSN-910			4995	6	-	lx	200	Wx	30,60	Προφίλ Εξωτερικής Στηρίξης Κολώνας FSN-103
						ly	183,17	Wy	28,18	External Fixation Profile for FSN-103
FSN-912			4609	6	-	lx	158	Wx	21,87	Προφίλ Βάσης Πλάγιας Στερέωσης
						ly	174,45	Wy	24,40	Ground Side Mount Fixing Profile
FSN-911			1955	6	-	lx	0,64	Wx	0,85	Προφίλ Βάσης Στερέωσης
						ly	45,09	Wy	10,02	Ground Fixing Profile
FSN-401			1142	6	-	lx	33,42	Wx	8,44	Προφίλ Εσωτερικού Στοιχείου
						ly	8,35	Wy	4,88	Inner Rail Profile
FSN-106			540	6	-	lx	0,42	Wx	0,71	Κολώνα Post Profile
						ly	5,33	Wy	2,13	
CLS-102			1245	6	-	lx	8,21	Wx	4,11	Κολώνα Post Profile
						ly	7,72	Wy	3,86	
F50-106			793	6	-	lx	6,70	Wx	3,35	Εσωτερικό προφίλ
						ly	6,85	Wy	3,42	Internal Profile
WD-4040			619.4	6	-	lx	2,95	Wx	1,26	Decorative Profile Διακοσμητικό προφίλ επένδυσης τοίχου
						ly	5,79	Wy	2,94	

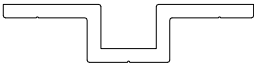
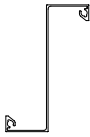
Κωδικός Code	Σχήμα Shape	Y X	Βάρος Weight gr/m	Μήκος Length m	Δέμα Pack	Ροπή Αδρανείας Moment of inertia cm ⁴		Ροπή αντιστάσεως Moment of resistance cm ³		Περιγραφή Description
						lx	ly	Wx	Wy	
CLS-3K1			450	6	-	lx	1,25	Wx	0,60	Καπάκι οδηγού CLS-301
						ly	9,25	Wy	3,09	Cover for guide CLS-301
CLS-301			588	6	-	lx	0,44	Wx	0,36	Οδηγός
						ly	7,37	Wy	2,59	Guide
CLS-3K2			324	6	-	lx	0,58	Wx	0,37	Καπάκι οδηγών
						ly	2,83	Wy	1,43	Cover for guide
CLS-302			359	6	-	lx	0,10	Wx	0,15	Οδηγός
						ly	2,09	Wy	1,06	Guide
5302-902			2416	6	-	lx	6,48	Wx	4,05	Mounting system Βάση στήριξης
						ly	72,6	Wy	13,14	
FSN-107			1010	6	-	lx	8,38	Wx	13,99	Mounting system Βάση στήριξης
						ly	18,3	Wy	4,65	

A photograph of a modern balcony or terrace. The railing is made of dark, vertical slats. In the background, there are two black wicker chairs and a small table. To the right, there is a living wall with green plants. The text "FUSION LINE: List of profiles 1:1" is overlaid in white on the image.

FUSION LINE: List of profiles 1:1

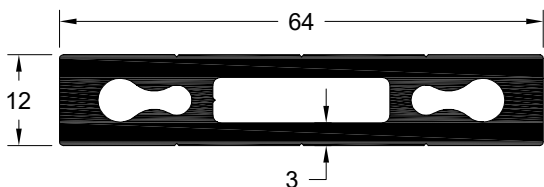

Κωδικός Code	FSN-100
Βάρος Weight	1442 gr/m
Περιγραφή	Κολώνα
Description	Post profile

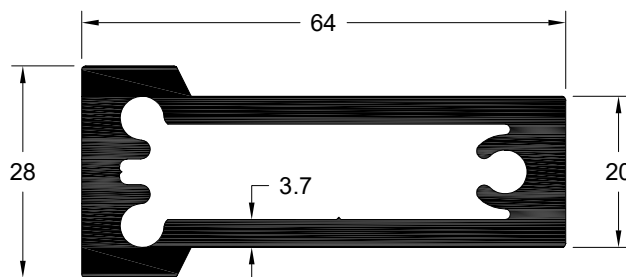

Κωδικός Code	FSN-101
Βάρος Weight	1980 gr/m
Περιγραφή	Κολώνα
Description	Post profile

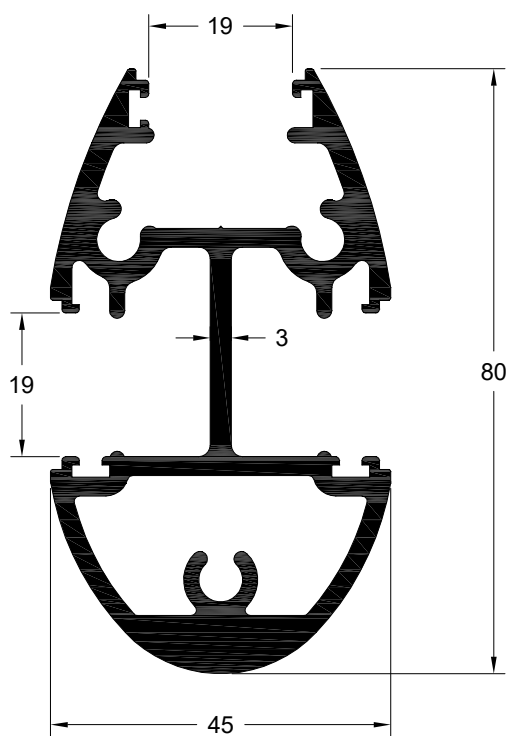

Κωδικός Code	FSN-102
Βάρος Weight	2384 gr/m
Περιγραφή	Κολώνα
Description	Column

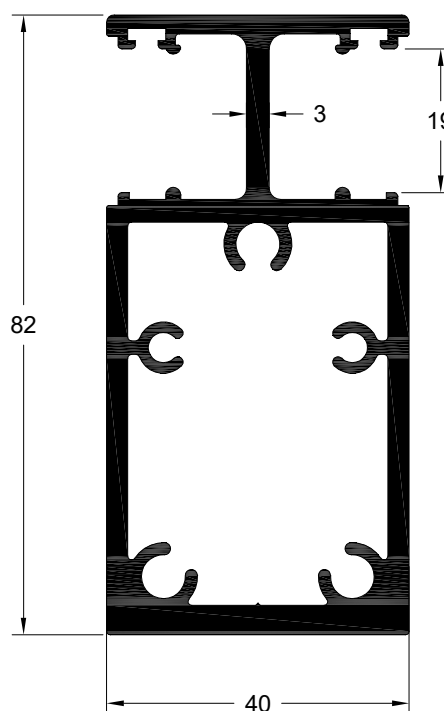

Κωδικός Code	FSN-103
Βάρος Weight	2367 gr/m
Περιγραφή	Κολώνα
Description	Column

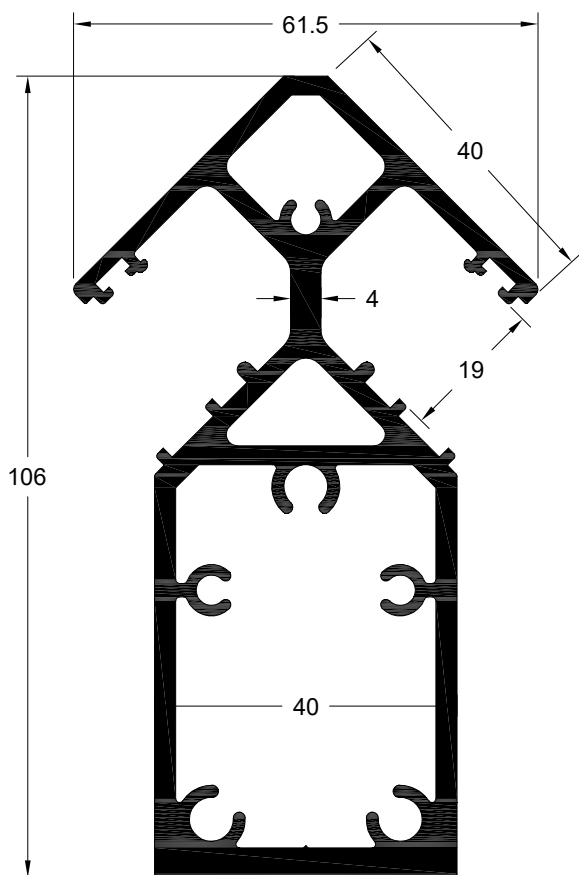

Κωδικός Code	FSN-104
Βάρος Weight	3118 gr/m
Περιγραφή	Κολώνα
Description	Column

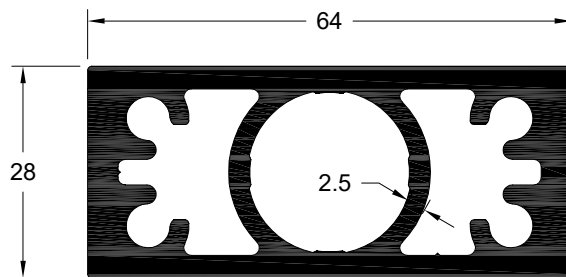

Κωδικός Code	FSN-105
Βάρος Weight	2367 gr/m
Περιγραφή	Κολώνα
Description	Column

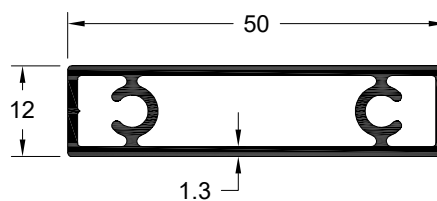

Κωδικός Code	FSN-106
Βάρος Weight	540 gr/m
Περιγραφή	Κολώνα
Description	Column

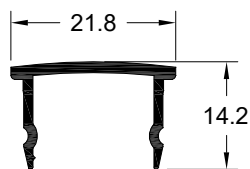

Κωδικός Code	FSN-122
Βάρος Weight	163 gr/m
Περιγραφή	Καπάκι
Description	Cover

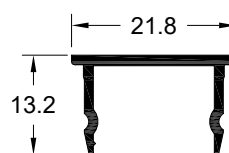

Κωδικός Code	FSN-123
Βάρος Weight	156 gr/m
Περιγραφή	Καπάκι
Description	Cover

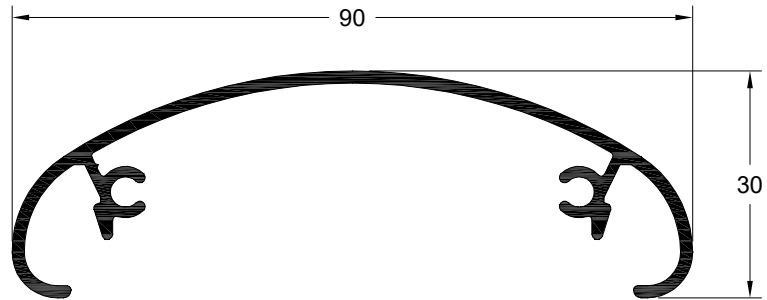

Κωδικός Code	FSN-222
Βάρος Weight	736 gr/m
Περιγραφή	Καπάκι οδηγού CLS-201
Description	Cover for guide CLS-201

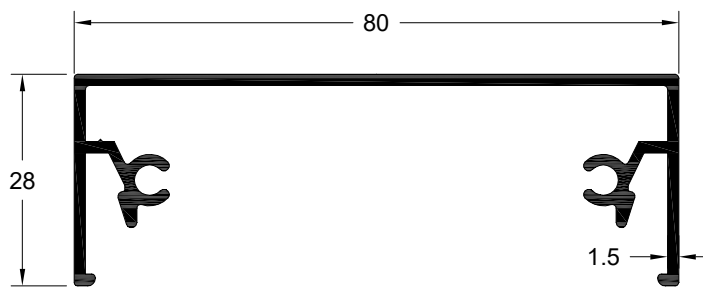

Κωδικός Code	FSN-221
Βάρος Weight	754 gr/m
Περιγραφή	Καπάκι οδηγού CLS-201
Description	Cover for guide CLS-201

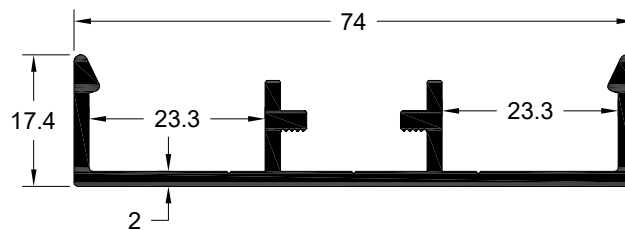

Κωδικός Code	CLS-201
Βάρος Weight	757 gr/m
Περιγραφή	Οδηγός Κουπαστης
Description	Handrail Guide

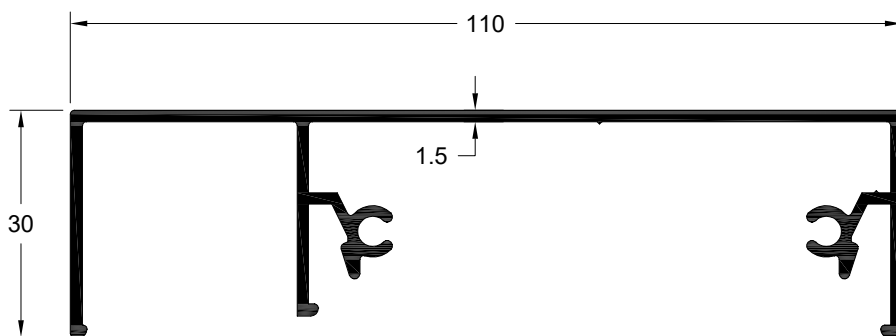

Κωδικός Code	FSN-223
Βάρος Weight	1006 gr/m
Περιγραφή	Καπάκι οδηγού FSN-203
Description	Cover for guide FSN-203

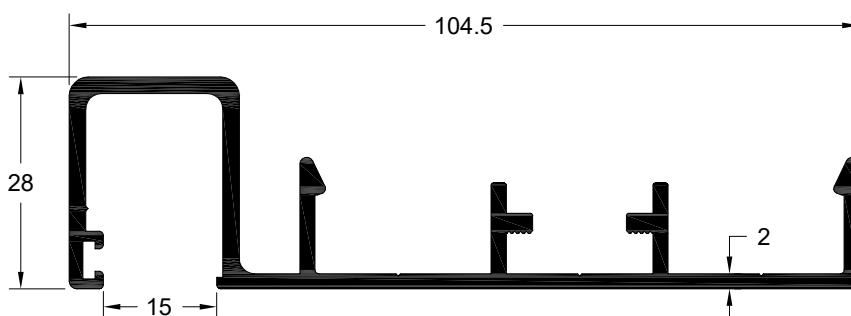

Κωδικός Code	FSN-203
Βάρος Weight	1260 gr/m
Περιγραφή	Οδηγός Κουπαστης
Description	Handrail Guide

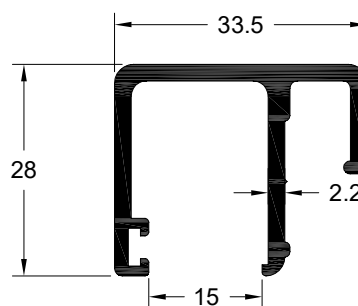
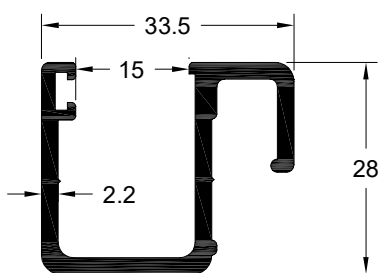

Κωδικός Code	FSN-300
Βάρος Weight	607 gr/m
Περιγραφή	Οδηγός Τζαμιου
Description	Glass Panel Guide

Κωδικός Code	FSN-301
Βάρος Weight	607 gr/m
Περιγραφή	Οδηγός Τζαμιου
Description	Glass Panel Guide

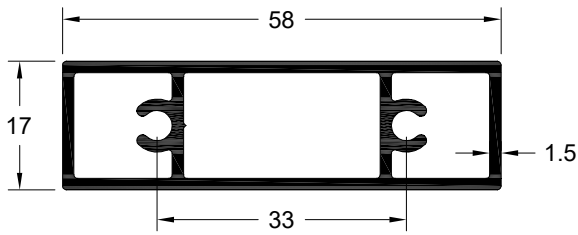

Κωδικός Code	FSN-302
Βάρος Weight	781 gr/m
Περιγραφή	Εσωτερικό
Description	Internal Profile

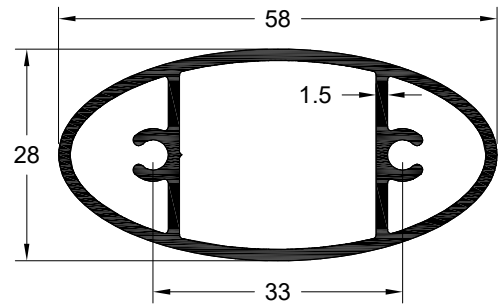

Κωδικός Code	FSN-304
Βάρος Weight	804 gr/m
Περιγραφή	Εσωτερικό
Description	Internal Profile

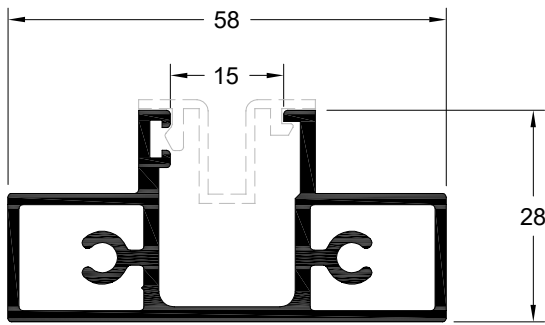

Κωδικός Code	FSN-303
Βάρος Weight	976 gr/m
Περιγραφή	Οδηγός Τζαμιου
Description	Glass Panel Guide

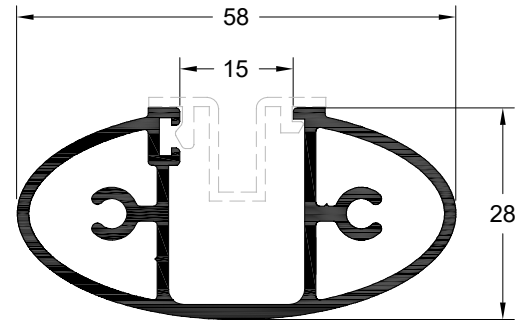

Κωδικός Code	FSN-306
Βάρος Weight	857 gr/m
Περιγραφή	Οδηγός Τζαμιου
Description	Glass Panel Guide

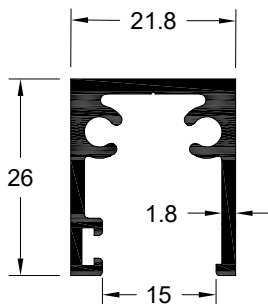

Κωδικός Code	FSN-307
Βάρος Weight	475 gr/m
Περιγραφή	Οδηγός Τζαμιου
Description	Glass Panel Guide

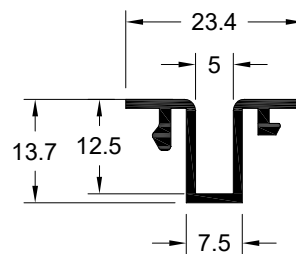

Κωδικός Code	FSN-308
Βάρος Weight	200 gr/m
Περιγραφή	Προσθηκη για Λαμαρινα
Description	Perforated Sheet Input

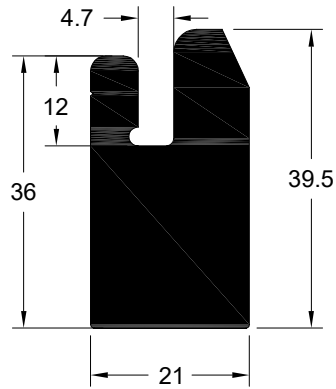

Κωδικός Code	FSN-901
Βάρος Weight	1931 gr/m
Περιγραφή	Προφιλ Στηριξης Οδηγού Τζαμιού
Description	Support Profile for Glass Panel Guide

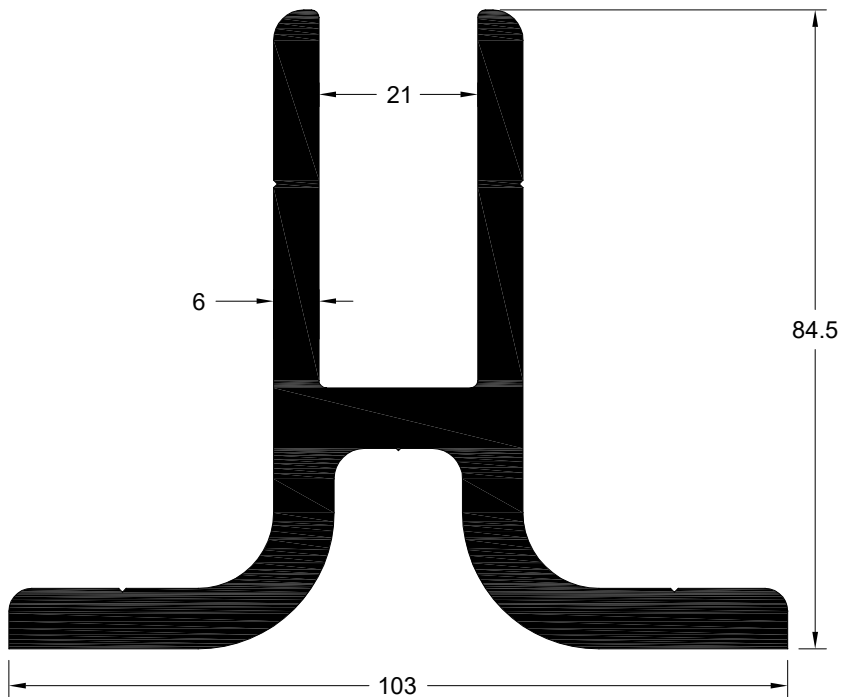

Κωδικός Code	FSN-903
Βάρος Weight	4717 gr/m
Περιγραφή	Προφιλ Εξωτερικής Στηριξης Κολωνας FSN-101
Description	External Fixation Profile for FSN-101

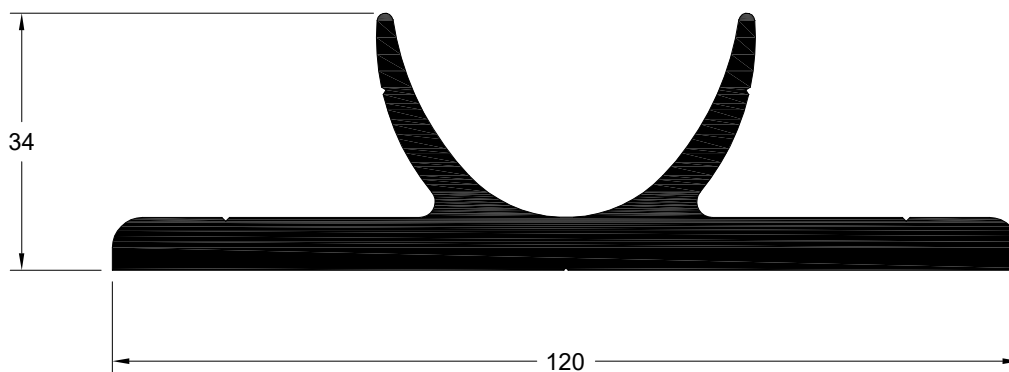

Κωδικός Code	FSN-904
Βάρος Weight	3005 gr/m
Περιγραφή	Προφίλ Στηριξης σε Τοίχο Κολωνας FSN-102
Description	Wall Support Profile for FSN-102

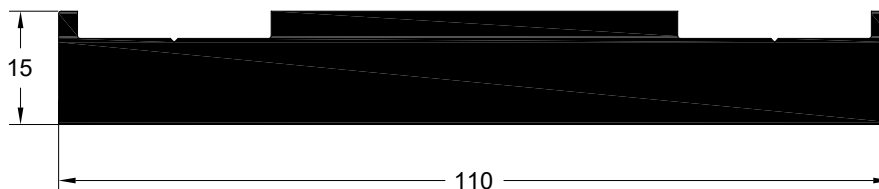

Κωδικός Code	FSN-906
Βάρος Weight	3956 gr/m
Περιγραφή	Προφίλ Πέλματος
Description	Post Footplate Profile

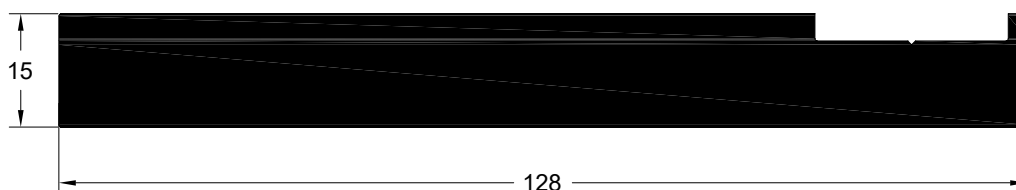

Κωδικός Code	FSN-907
Βάρος Weight	4938 gr/m
Περιγραφή	Προφίλ Γωνιακού Πέλματος
Description	Corner Post Footplate Profile



Κωδικός Code	FSN-908
Βάρος Weight	369 gr/m
Περιγραφή	Προφίλ Καπάκι Πελμάτων
Description	Footplate Cover

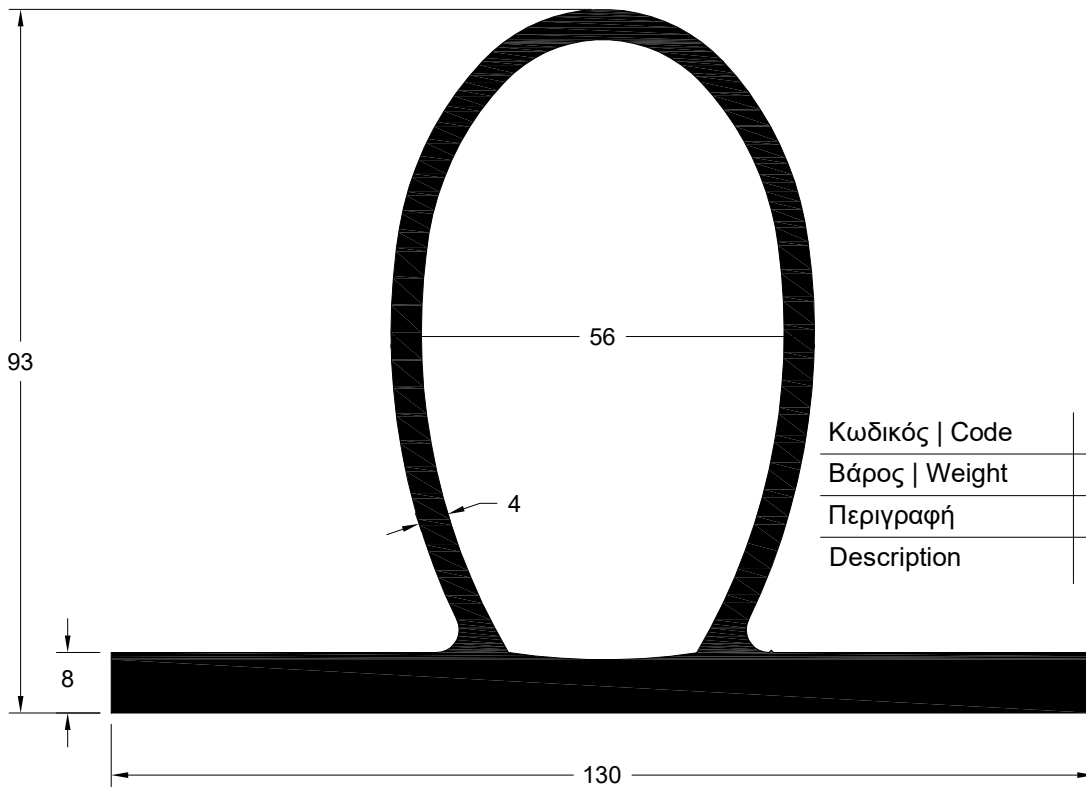

Κωδικός Code	FSN-909
Βάρος Weight	4907 gr/m
Περιγραφή Description	Εξωτερική Στήριξη FSN-102 External Fixation FSN-102

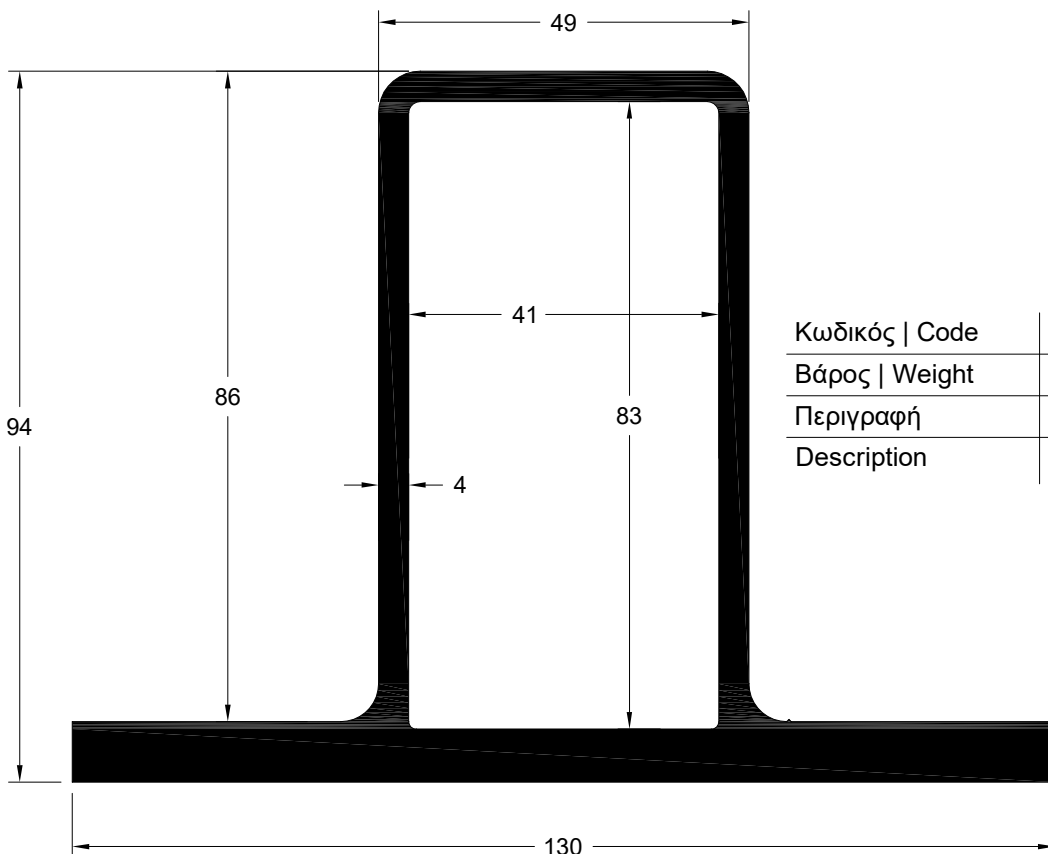

Κωδικός Code	FSN-910
Βάρος Weight	4995 gr/m
Περιγραφή Description	Εξωτερική Στήριξη FSN-103 External Fixation FSN-103

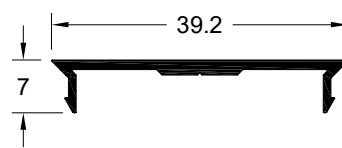
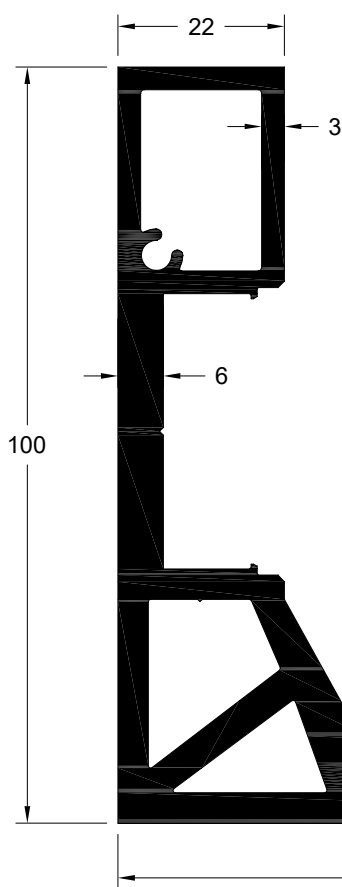

Code Κωδικός	WD-5001
Weight Βάρος	187 gr/m
Description	Cover profile
Περιγραφή	Καπάκι

Κωδικός Code	FSN-912
Βάρος Weight	4609 gr/m
Περιγραφή	Προφίλ Βάσης Πλάγιας Στερέωσης
Description	Ground Side Mount Fixing Profile

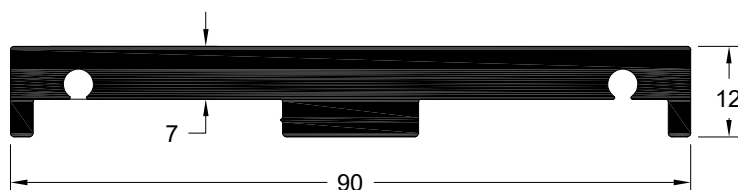
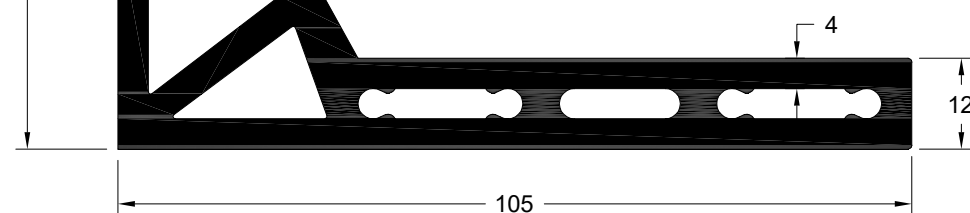

Κωδικός Code	FSN-911
Βάρος Weight	1955 gr/m
Περιγραφή	Προφίλ Βάσης Στερέωσης
Description	Ground Fixing Profile

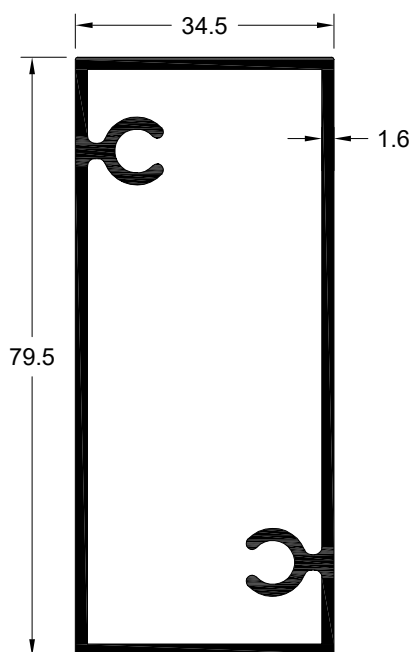

Κωδικός Code	FSN-401
Βάρος Weight	1142 gr/m
Περιγραφή	Προφίλ Εσωτερικού Στοιχείου
Description	Inner Rail Profile

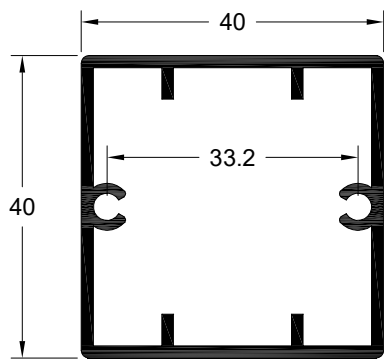

Κωδικός Code	F50-106
Βάρος Weight	793 gr/m
Περιγραφή	Εσωτερικό
Description	Internal profile

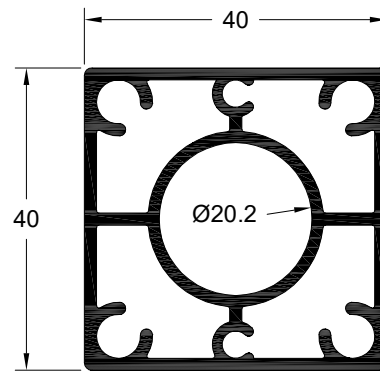

Κωδικός Code	CLS-102
Βάρος Weight	1245 gr/m
Περιγραφή	Κολώνα
Description	Post profile

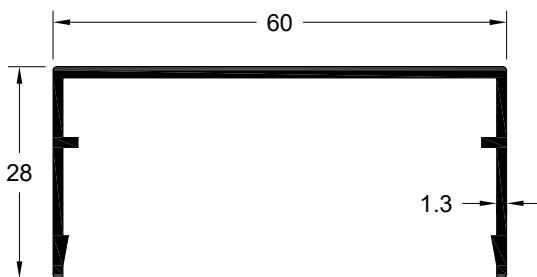

Κωδικός Code	CLS-3K1
Βάρος Weight	450 gr/m
Περιγραφή	Καπάκι οδηγού CLS-301
Description	Cover for guide CLS-301

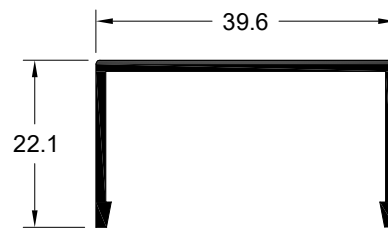

Κωδικός Code	CLS-3K2
Βάρος Weight	324 gr/m
Περιγραφή	Καπάκι οδηγών
Description	Cover for guide

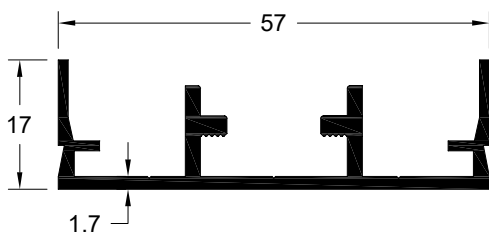

Κωδικός Code	CLS-301
Βάρος Weight	588 gr/m
Περιγραφή	Οδηγός
Description	Guide

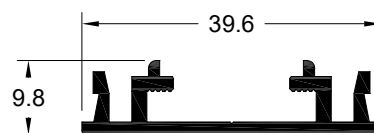

Κωδικός Code	CLS-302
Βάρος Weight	359 gr/m
Περιγραφή	Οδηγός
Description	Guide

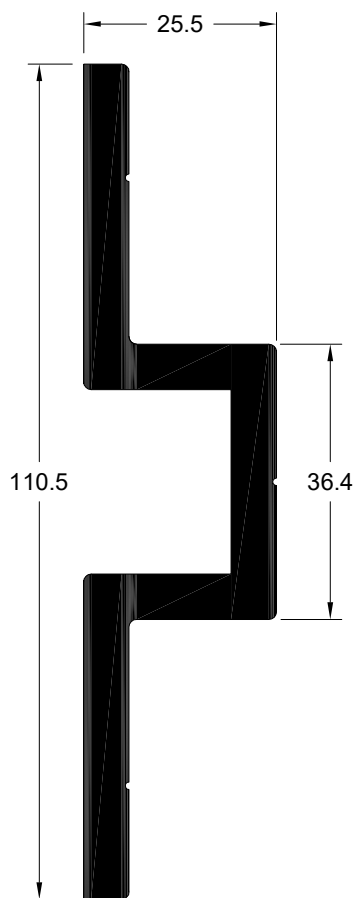

Code Κωδικός	5302-902
Weight Βάρος	2416 gr/m
Description	Mounting system
Περιγραφή	Βάση στήριξης

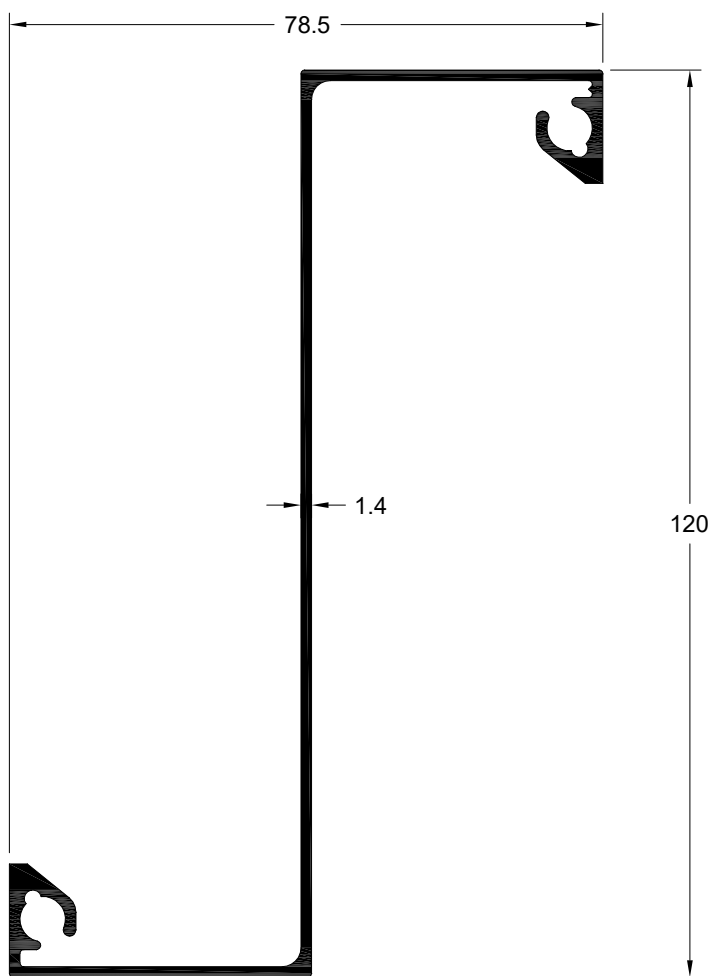

Code Κωδικός	FSN-107
Weight Βάρος	1010 gr/m
Description	Fence Upright
Περιγραφή	Ορθοστάτης Φράκτη

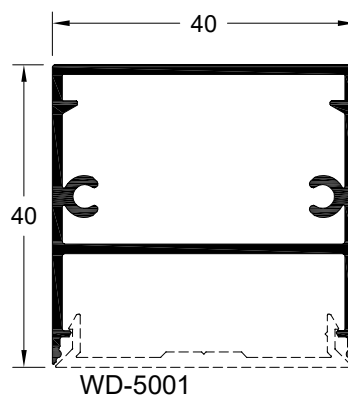

Code Κωδικός	WD-4040
Weight Βάρος	619.4 gr/m
Description	Decorative Profile
Περιγραφή	Διακοσμητικό προφίλ επένδυσης τοίχου

Linea V



LineaV

Balustrades: Top Mount



1

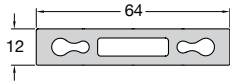

Code/Κωδικός **FSN-100**
Weight/Βάρος 1442 gr/m

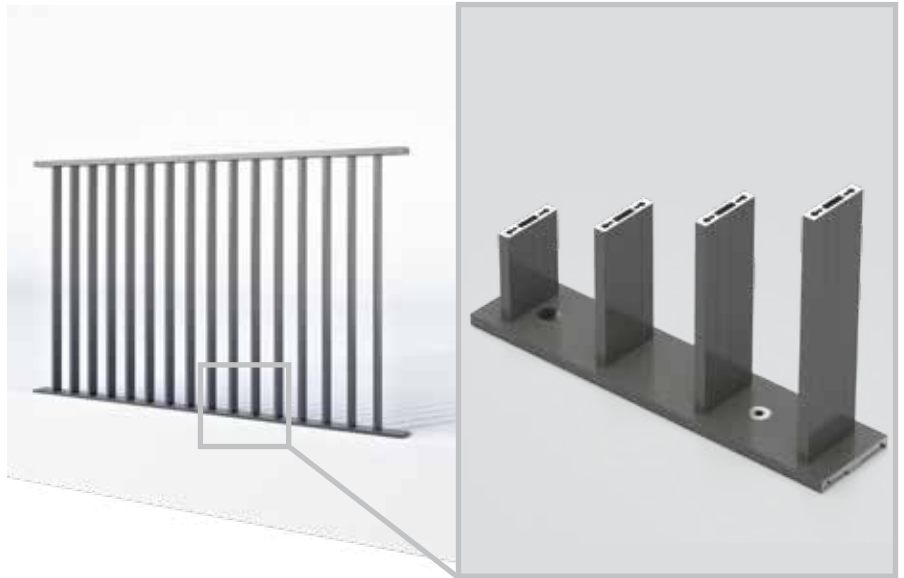

2

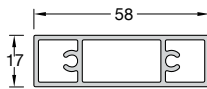

Code/Κωδικός **FSN-302**
Weight/Βάρος 781 gr/m

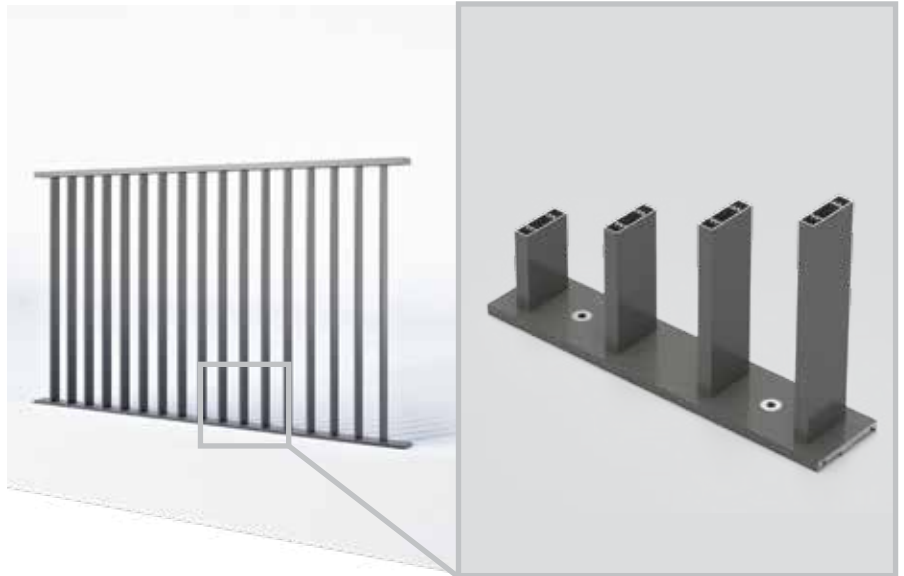

3

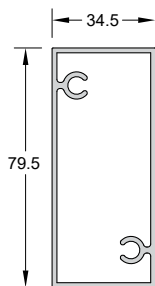

Code/Κωδικός **FSN-401**
Weight/Βάρος 1142 gr/m
Length/Μήκος 6 m

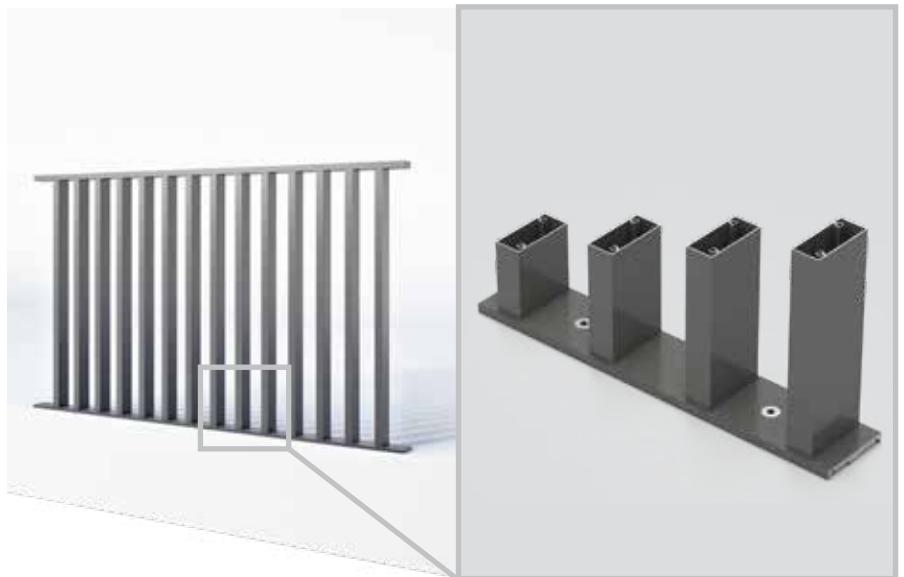

4

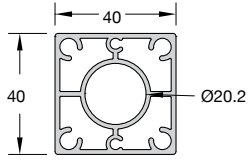

Code/Κωδικός **CLS-102**
 Weight/Βάρος 1245 gr/m
 Length/Μήκος 6 m

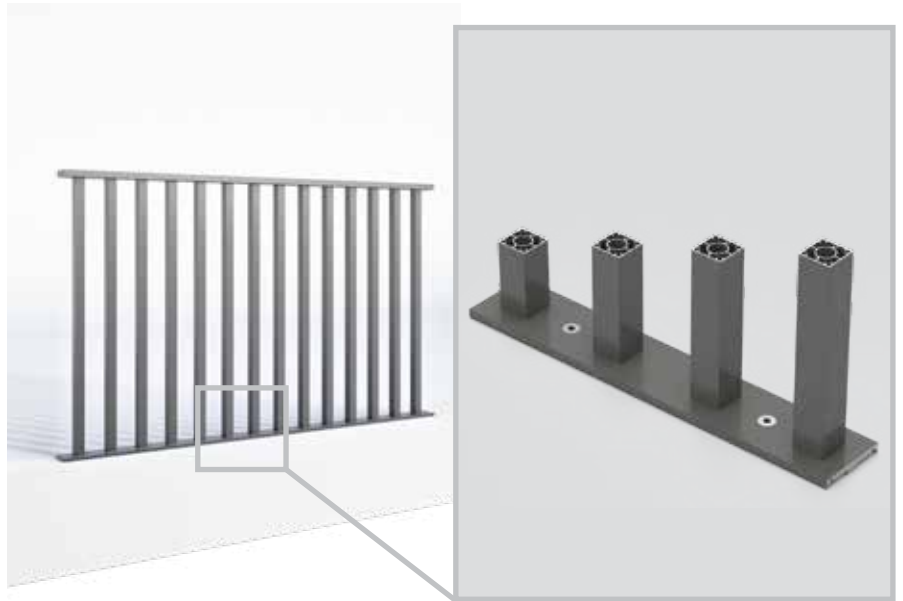

5

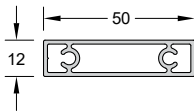

Code/Κωδικός **FSN-106**
 Weight/Βάρος 540 gr/m
 Length/Μήκος 6 m

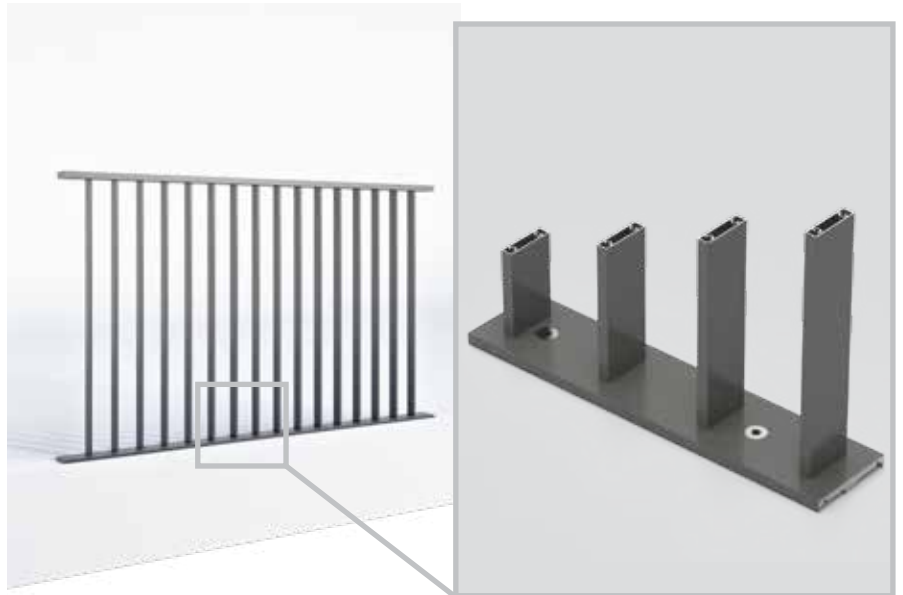

Top Mount Typical Assembly - FSN 106/ FSN-911

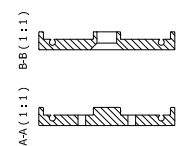
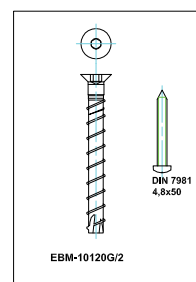
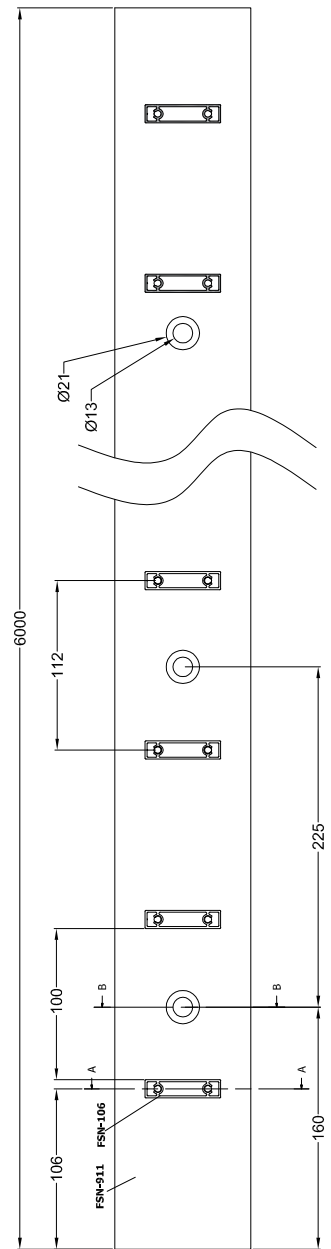
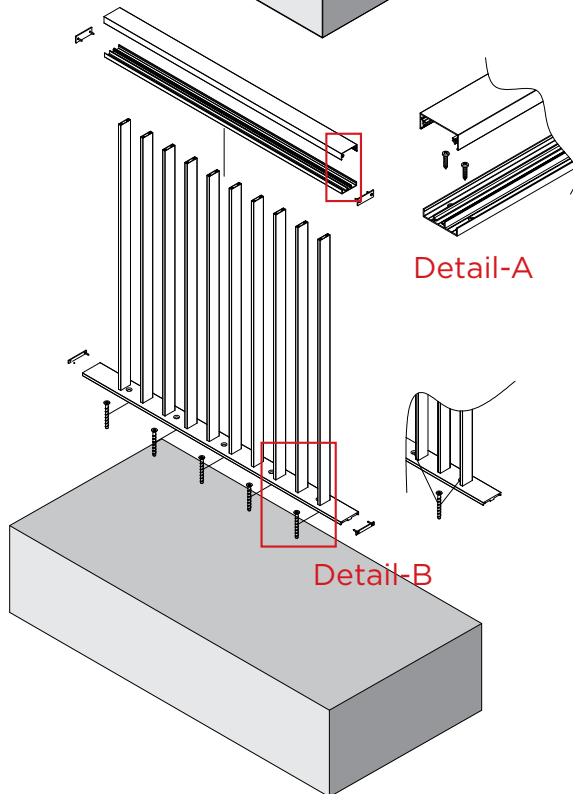
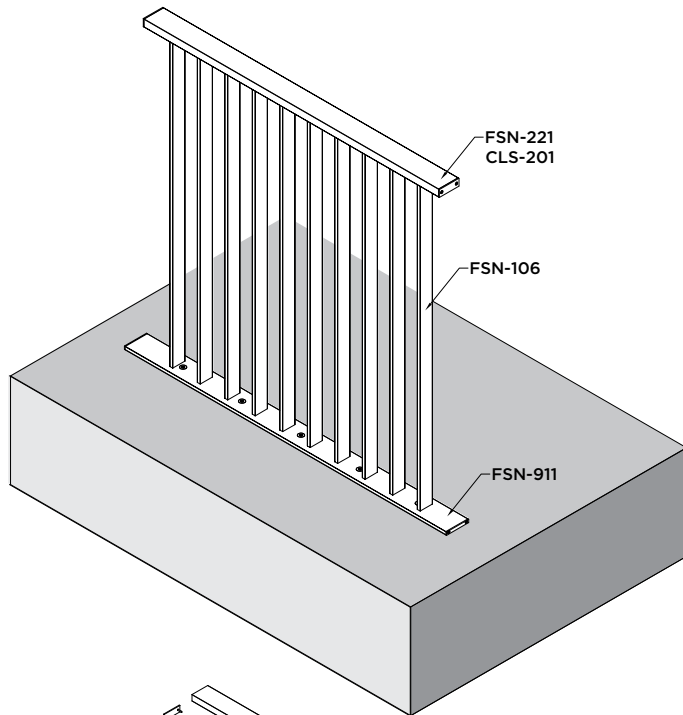

New Fusion Line Type:
 Top Mount FSN-106 BALUSTRADE (TOP MOUNT UNIFORM BASE)

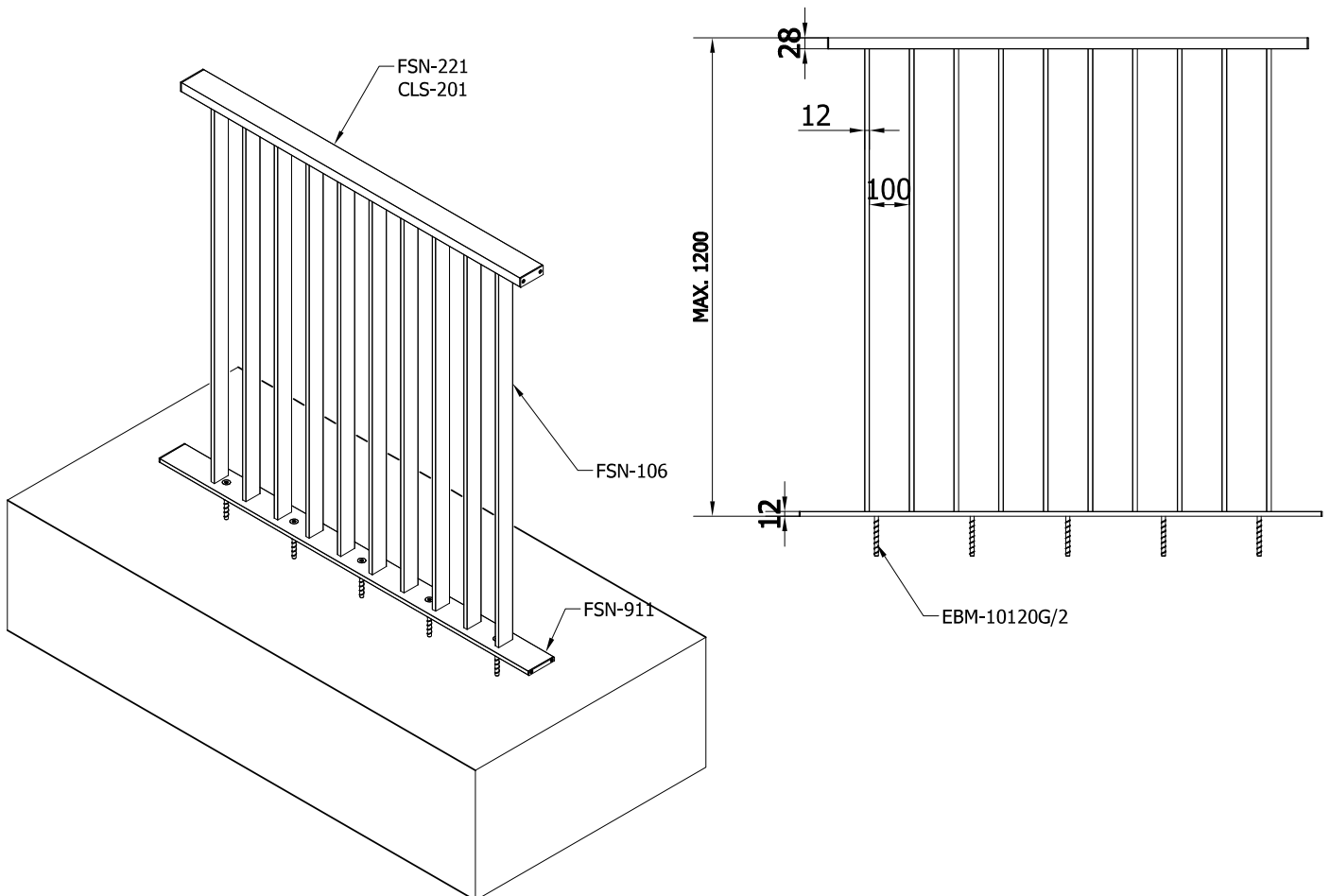

New Fusion Line Type: Top Mount FSN-401 BALUSTRADE

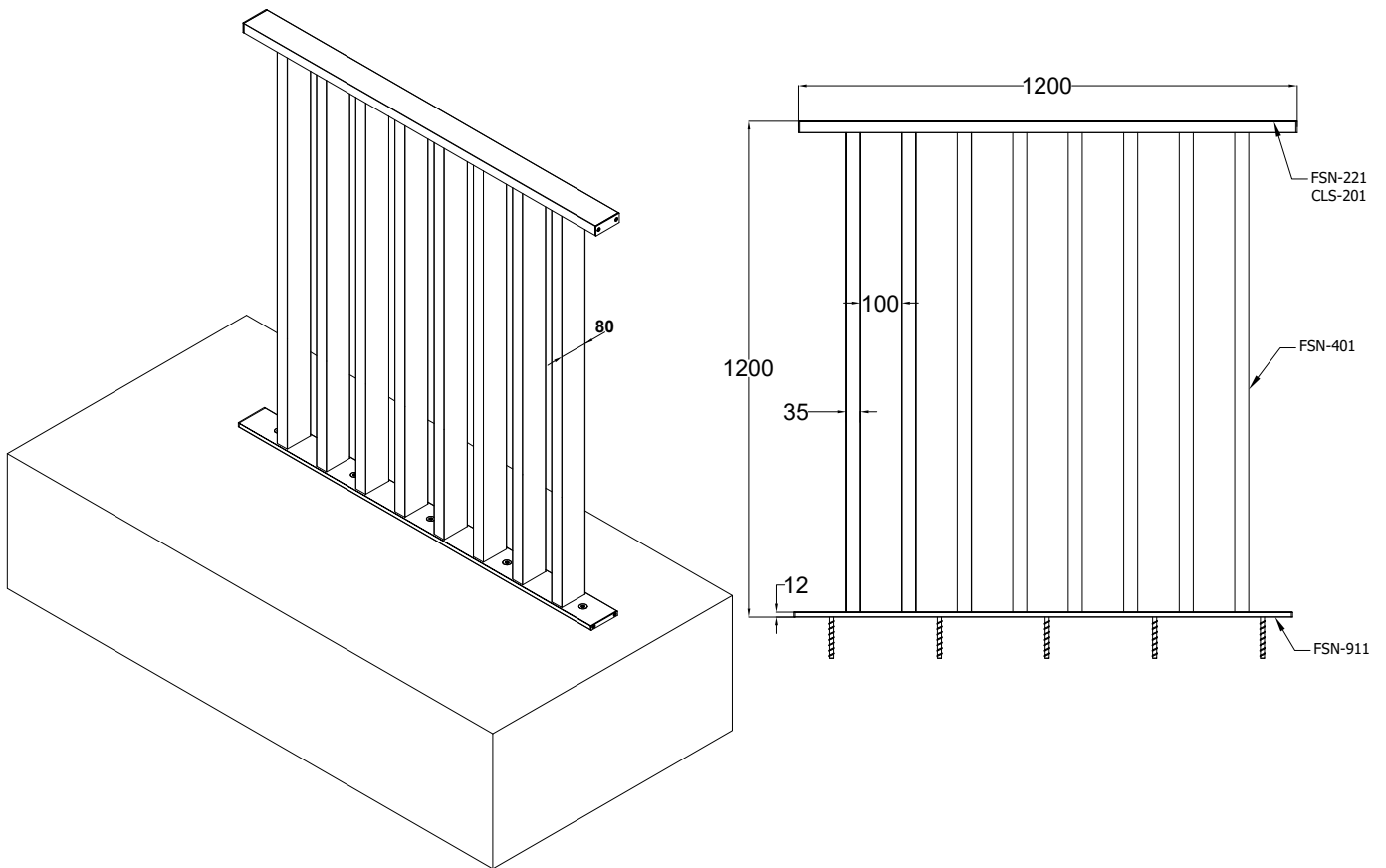

New Fusion Line Type: Top Mount FSN-302 BALUSTRADE

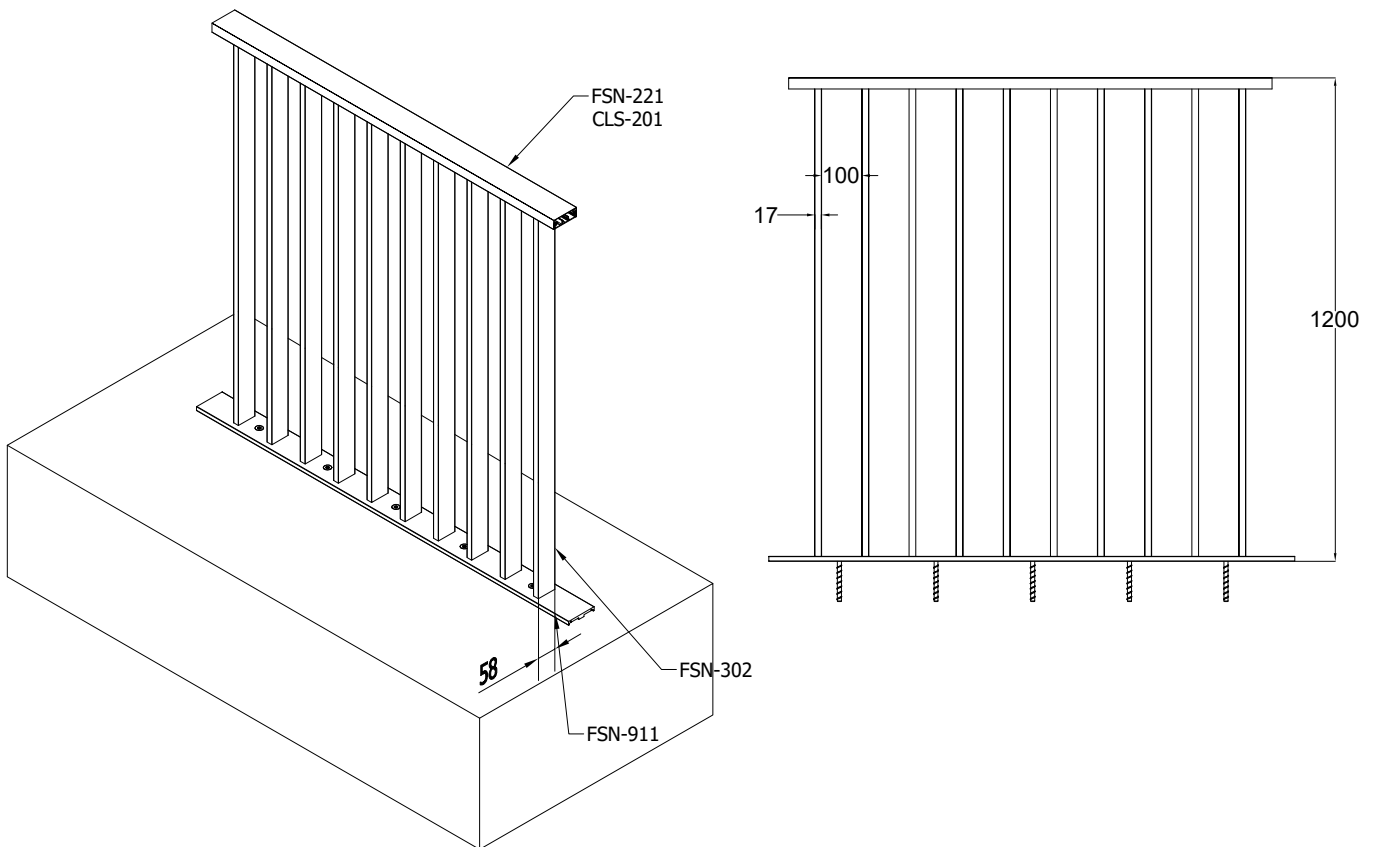

New Fusion Line Type:
Top Mount FSN-100 BALUSTRADE TYPE with FOOTPLATES

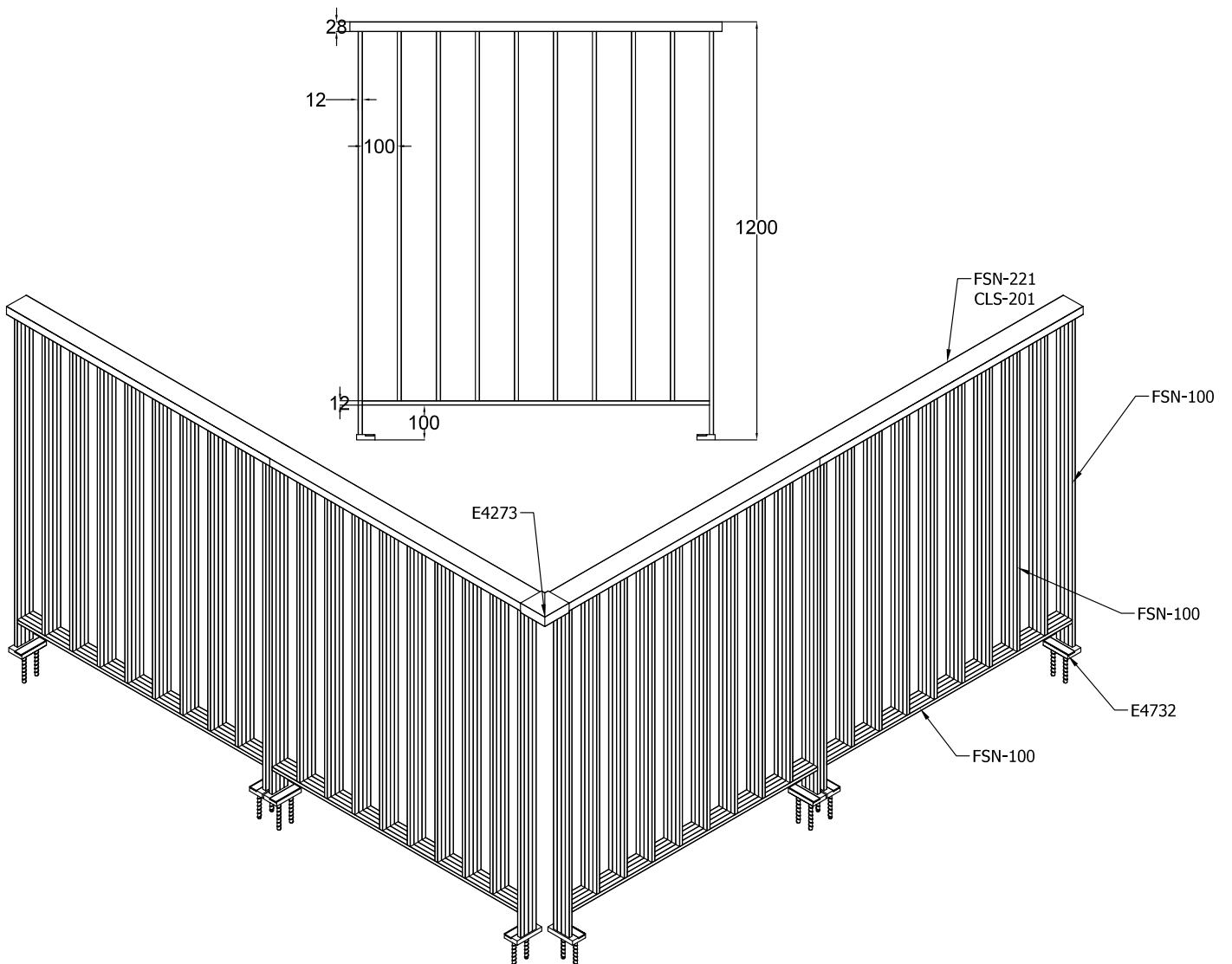

New Fusion Line Type: Top Mount FSN-106 BALUSTRADE TYPE with FOOTPLATES

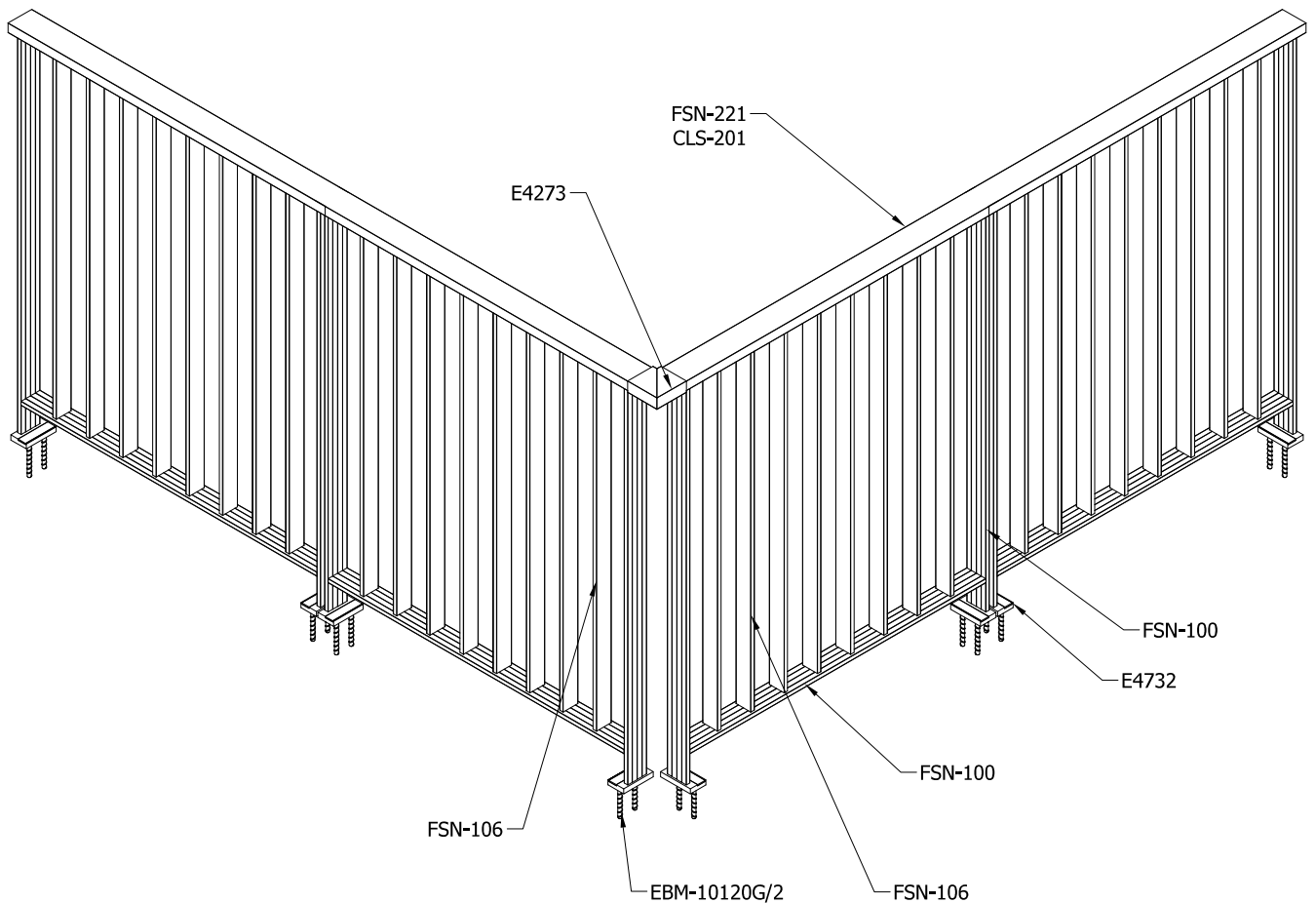
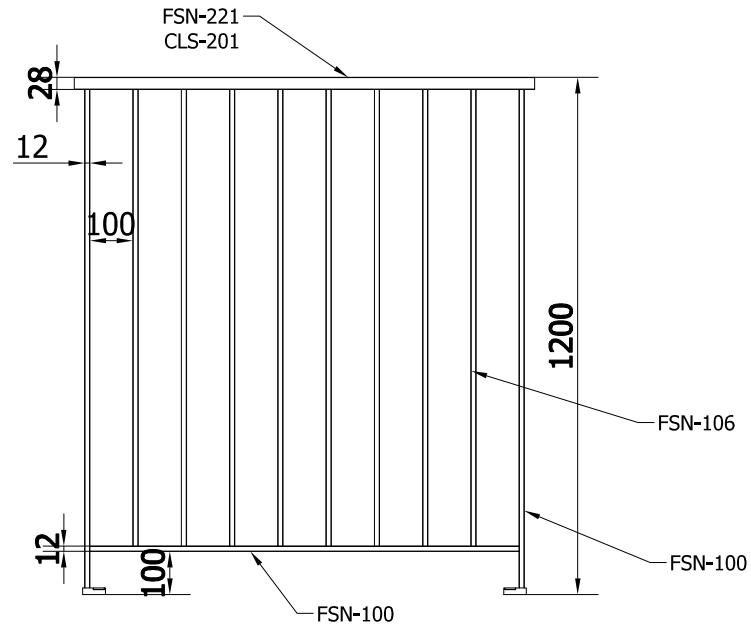

Fusion Line -Top Mount - Continuous

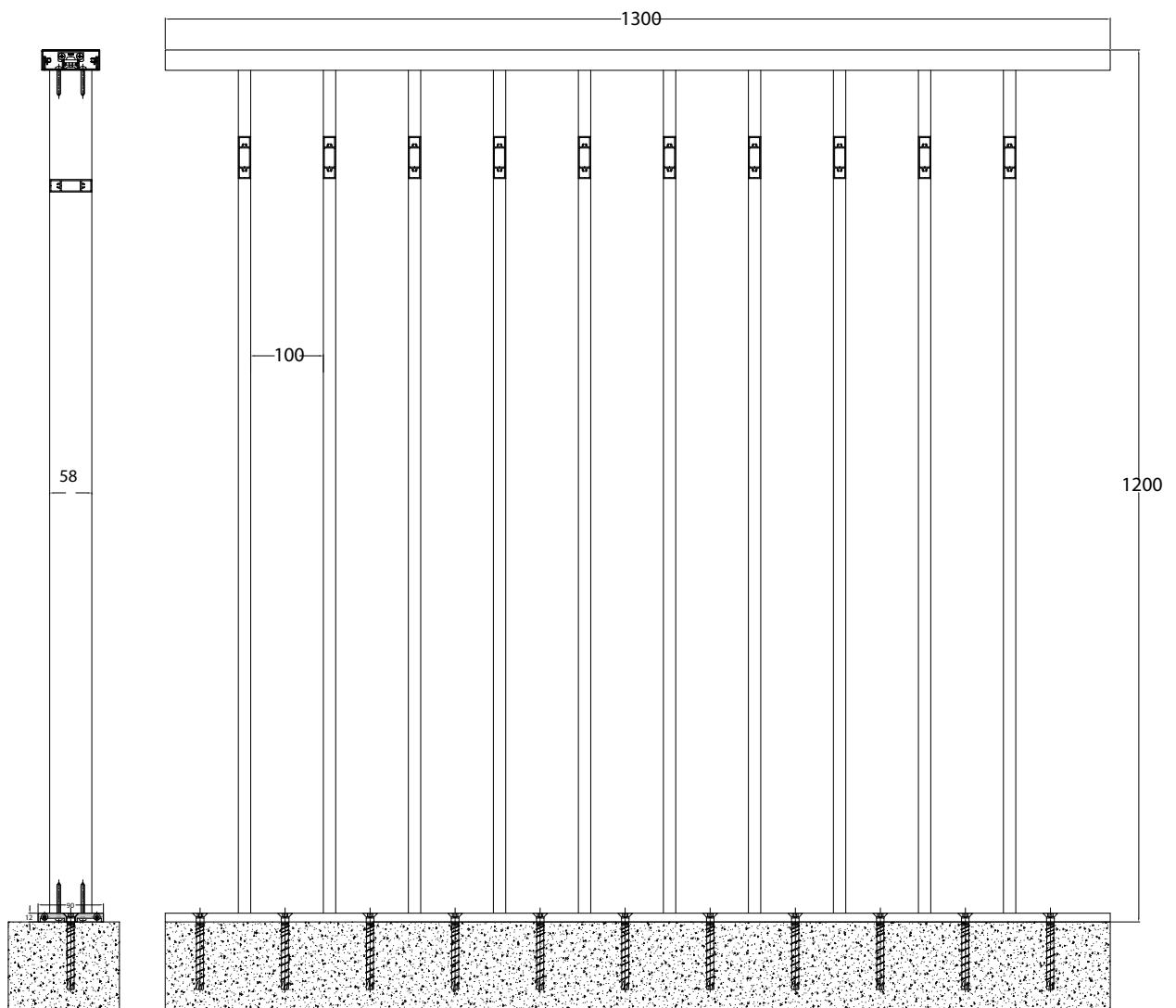

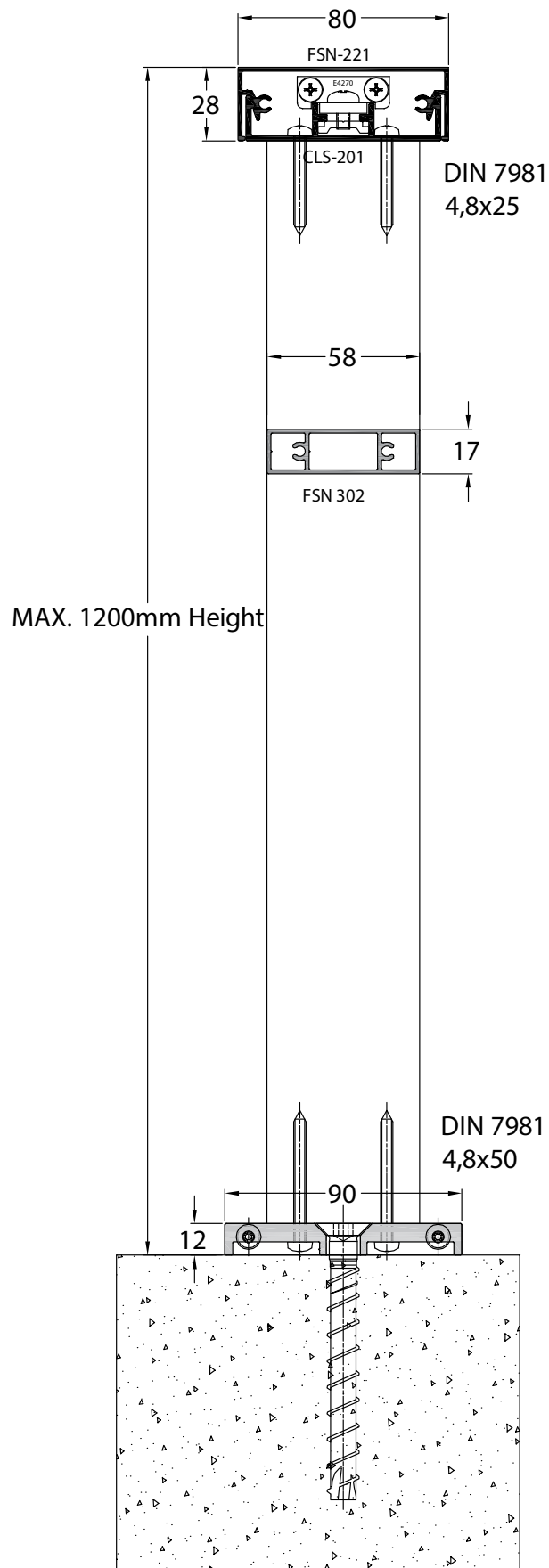

Fusion Line - Modular Panel

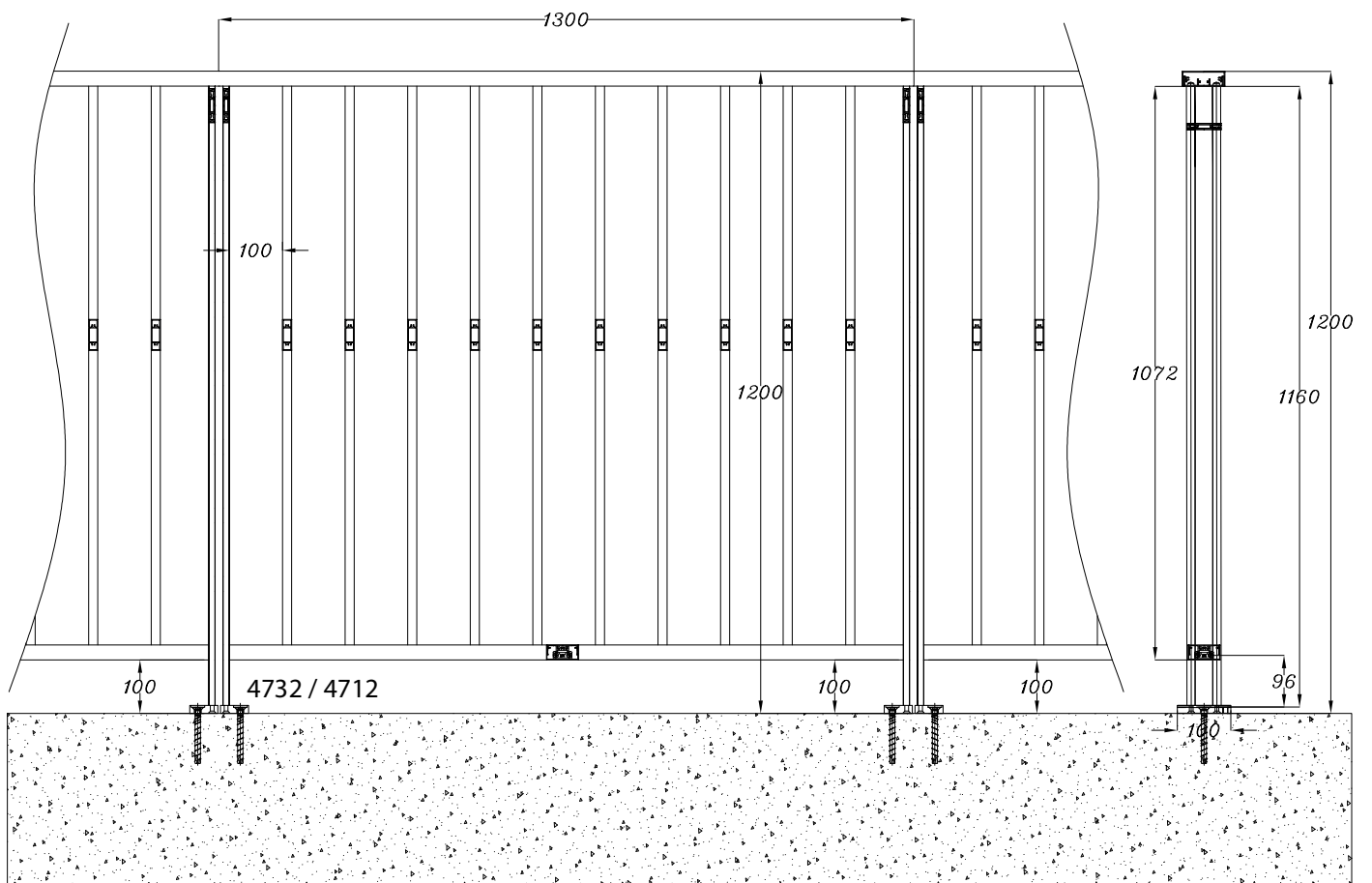

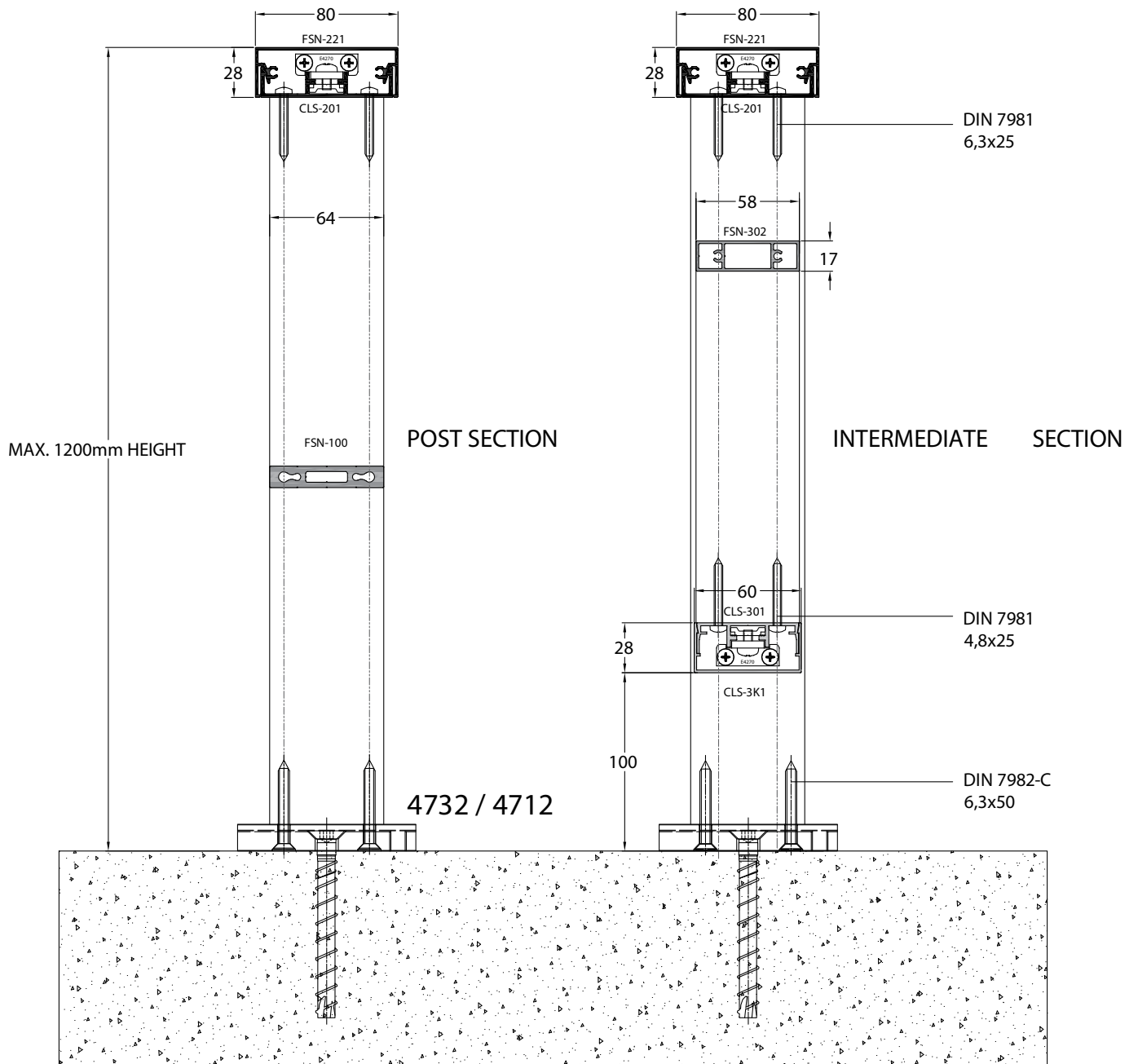

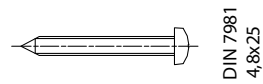
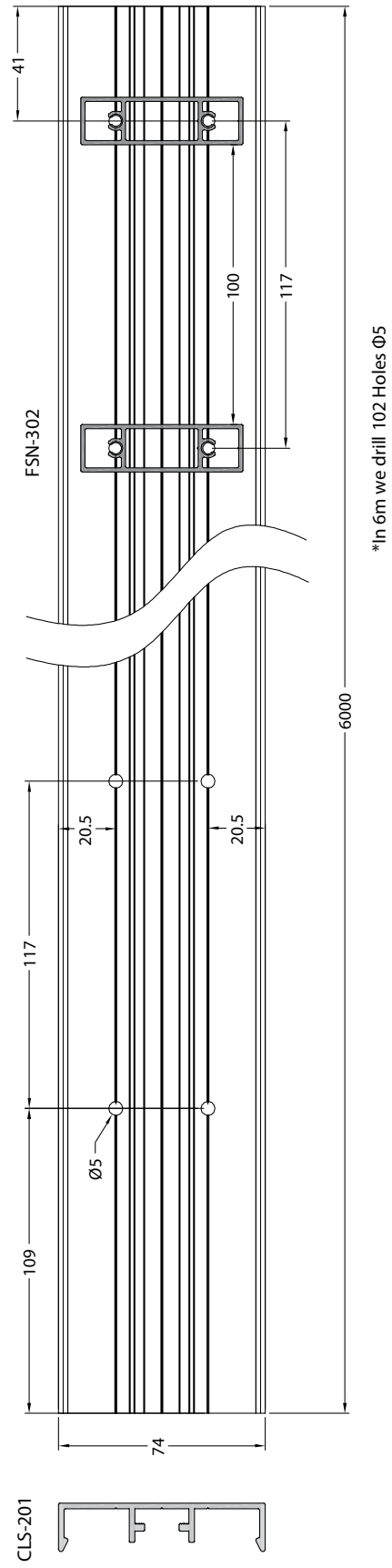
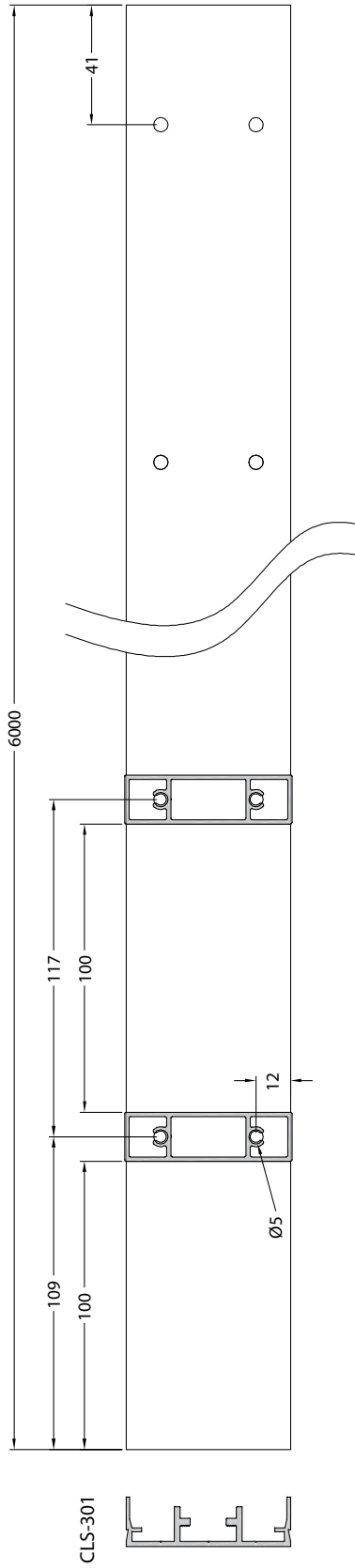

New Fusion Line Type:
Top Mount CLS-102 BALUSTRADE TYPE

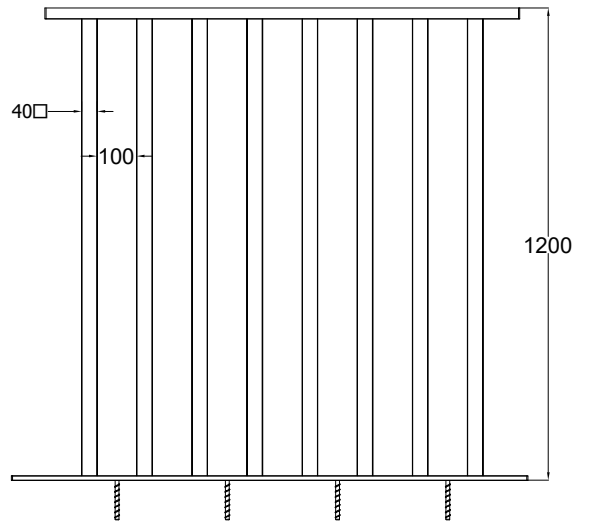
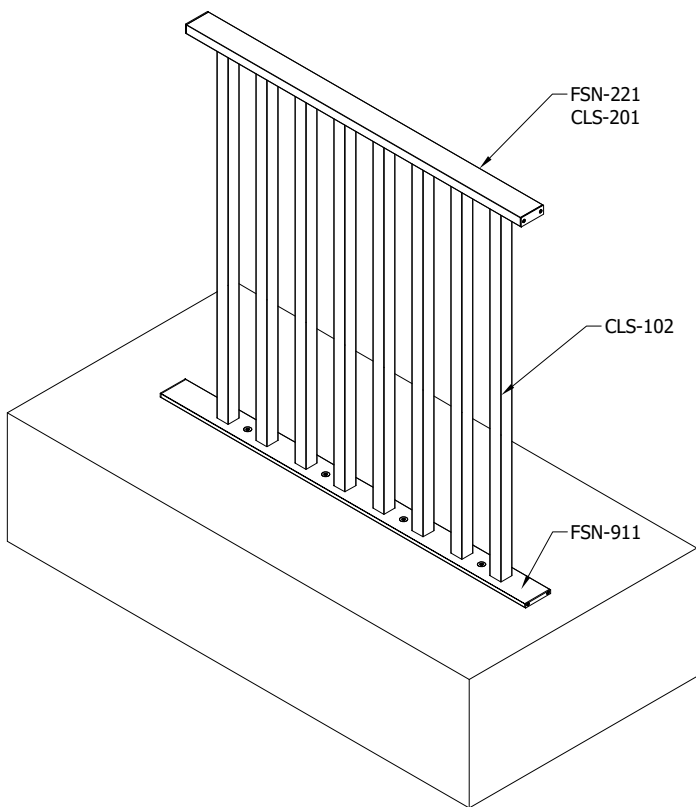

New Fusion Line Type: Top Mount FSN-102 BALUSTRADE TOP MOUNT with WALL & DECO

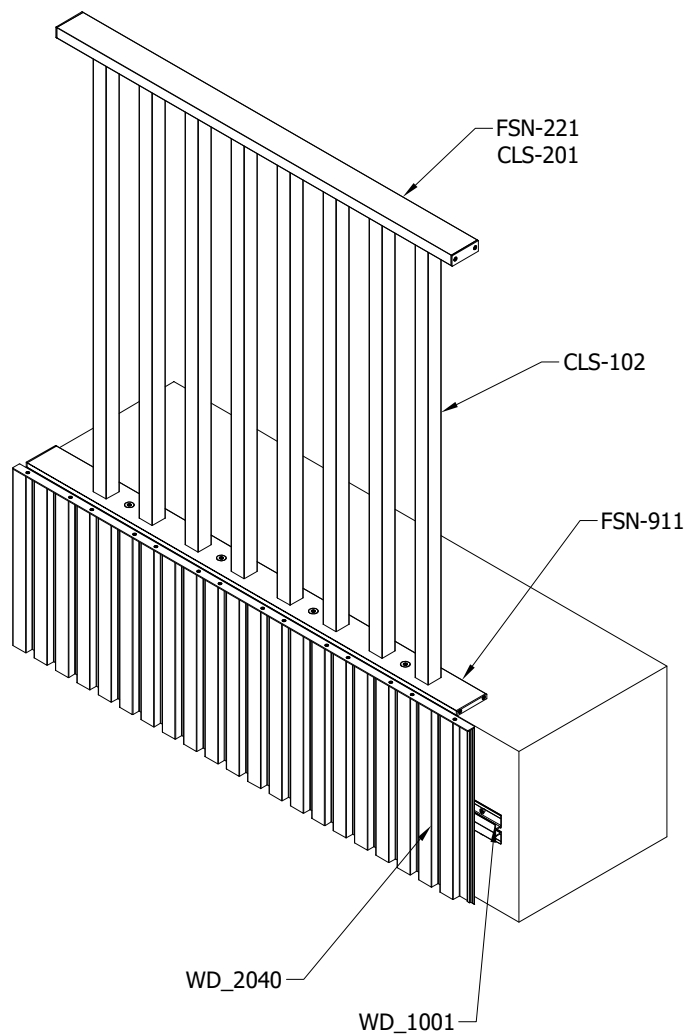
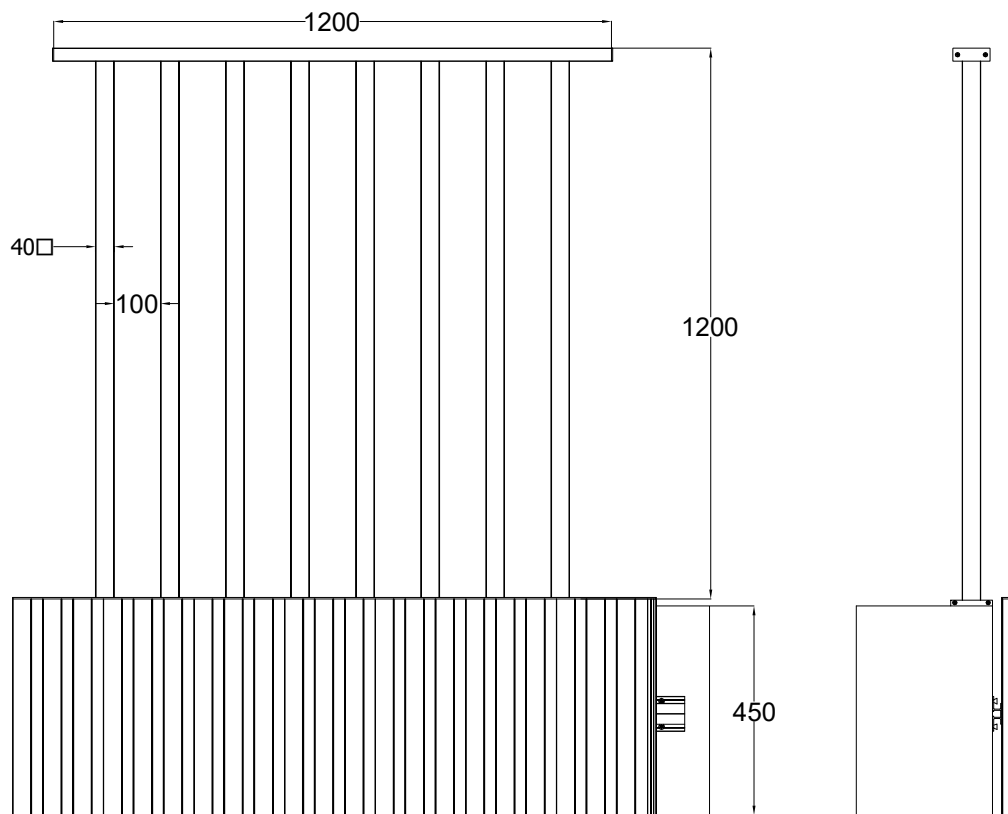

LineaV Top mount Ground fixing guide



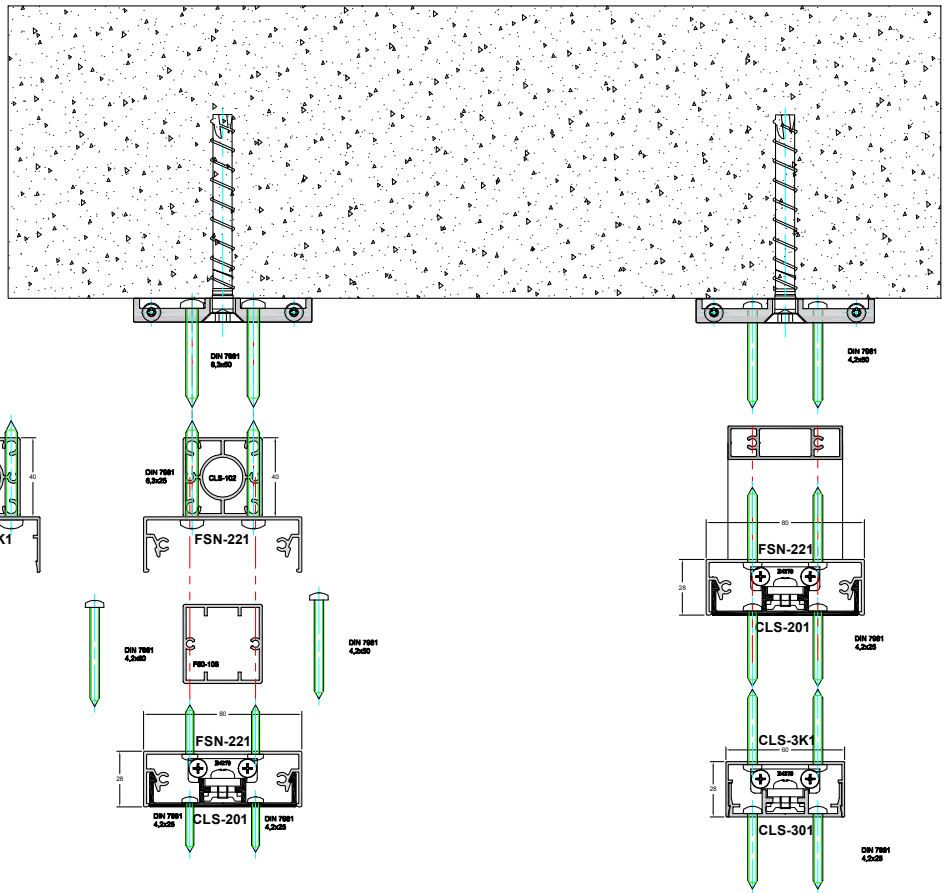

TOP MOUNT

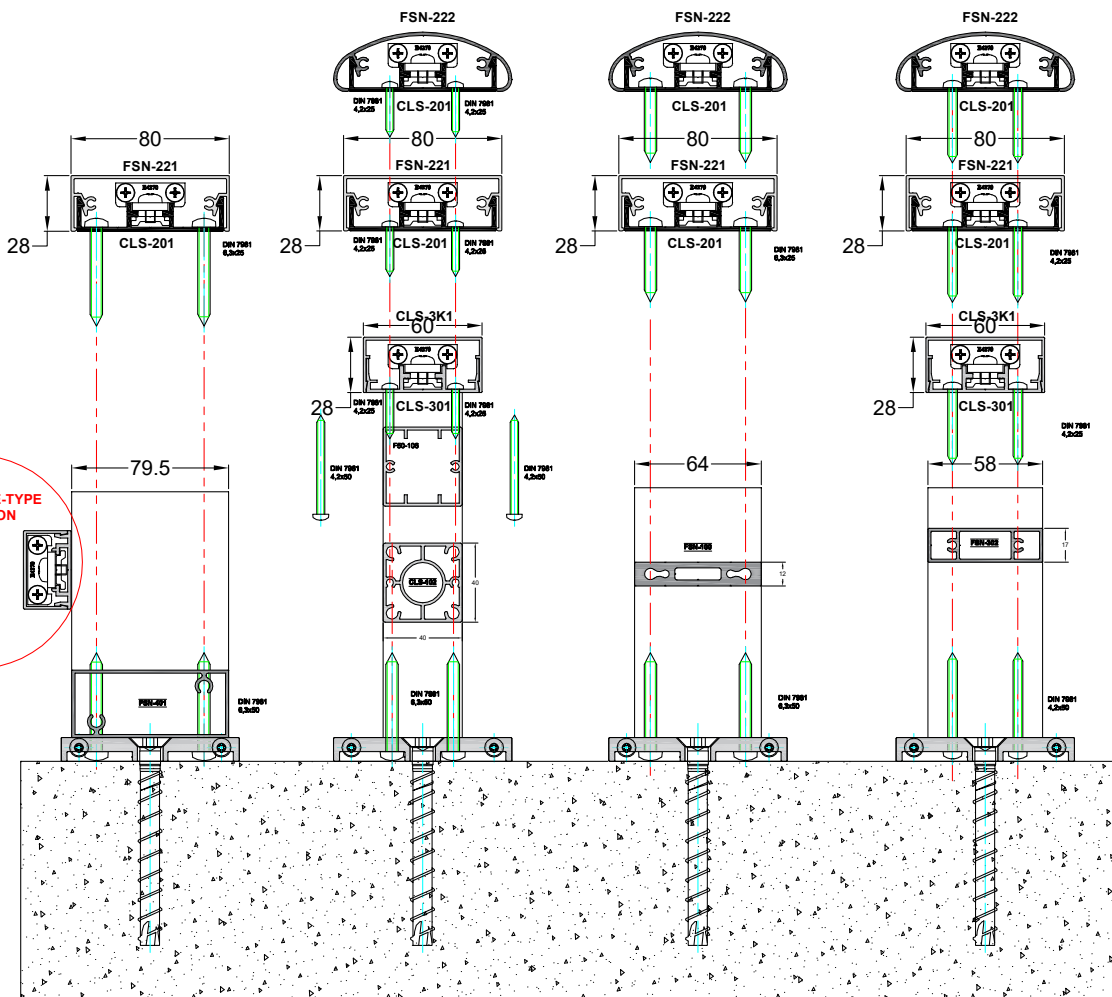

NEW FUSION LINE FSN-106 TOP MOUNT INSTALLATION

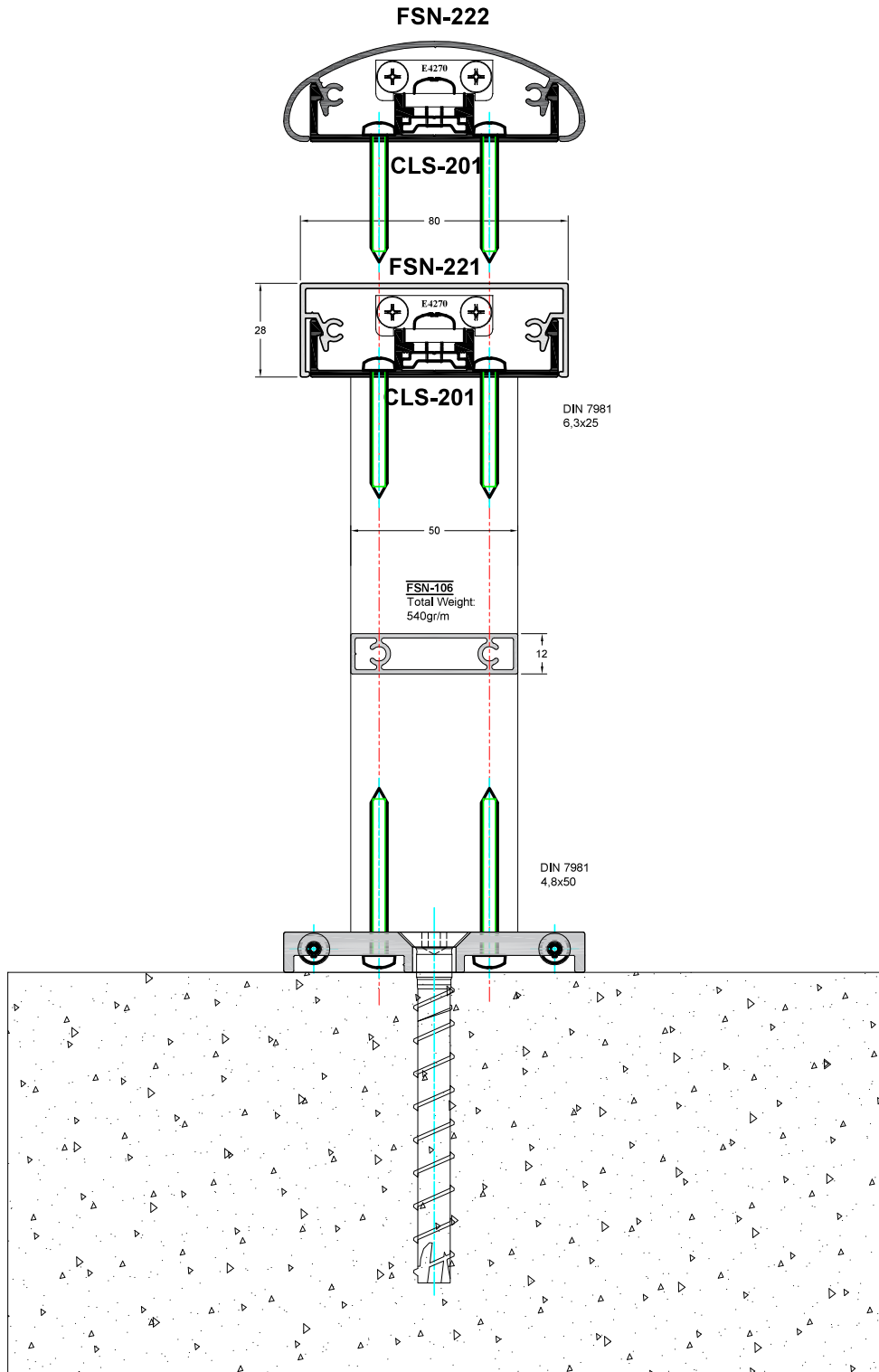

FSN-221_CLS-102 LINEAR HOLE CUTTINGS

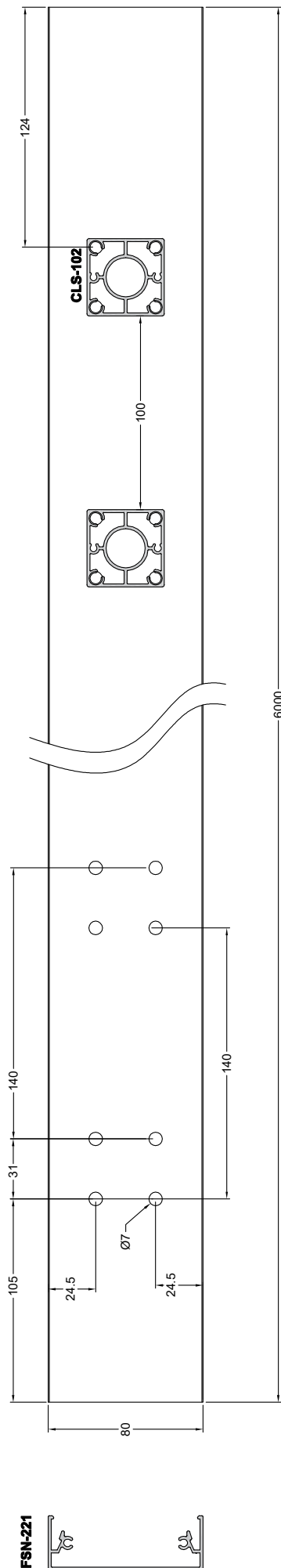

* Στο 6μ προφίλ κάνουμε 84 Τρύπες Ø7



DIN 7981
6.3x25

CLS-201_CLS-102 LINEAR HOLE CUTTINGS

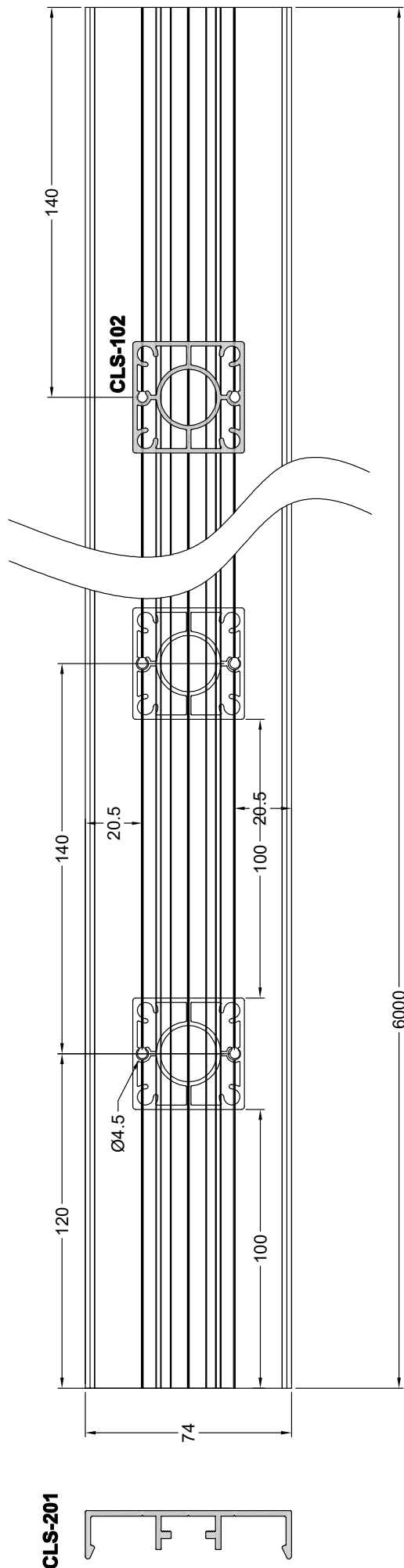

* Στο 6μ προφίλ κάνουμε 84 Τρύπες Φ4.5



DIN 7981
4,2x25

FSN-221_F50-106_CLS-102 LINEAR HOLE CUTTINGS

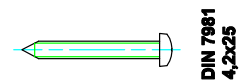
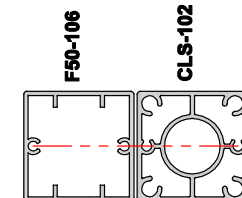
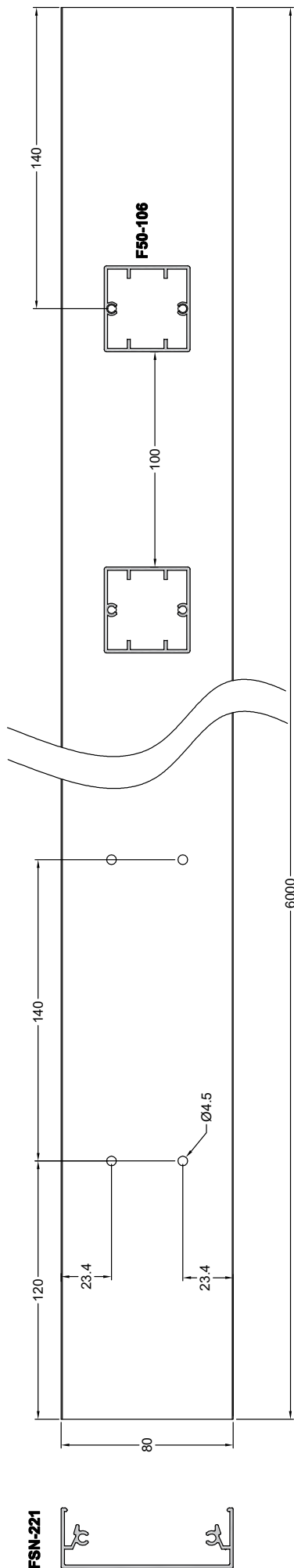

* Στο 6μ προφίλ κάνουμε 84 Τρύπες $\varnothing 4.5$

CLS-201_F50-106_CLS-102 LINEAR HOLE CUTTINGS

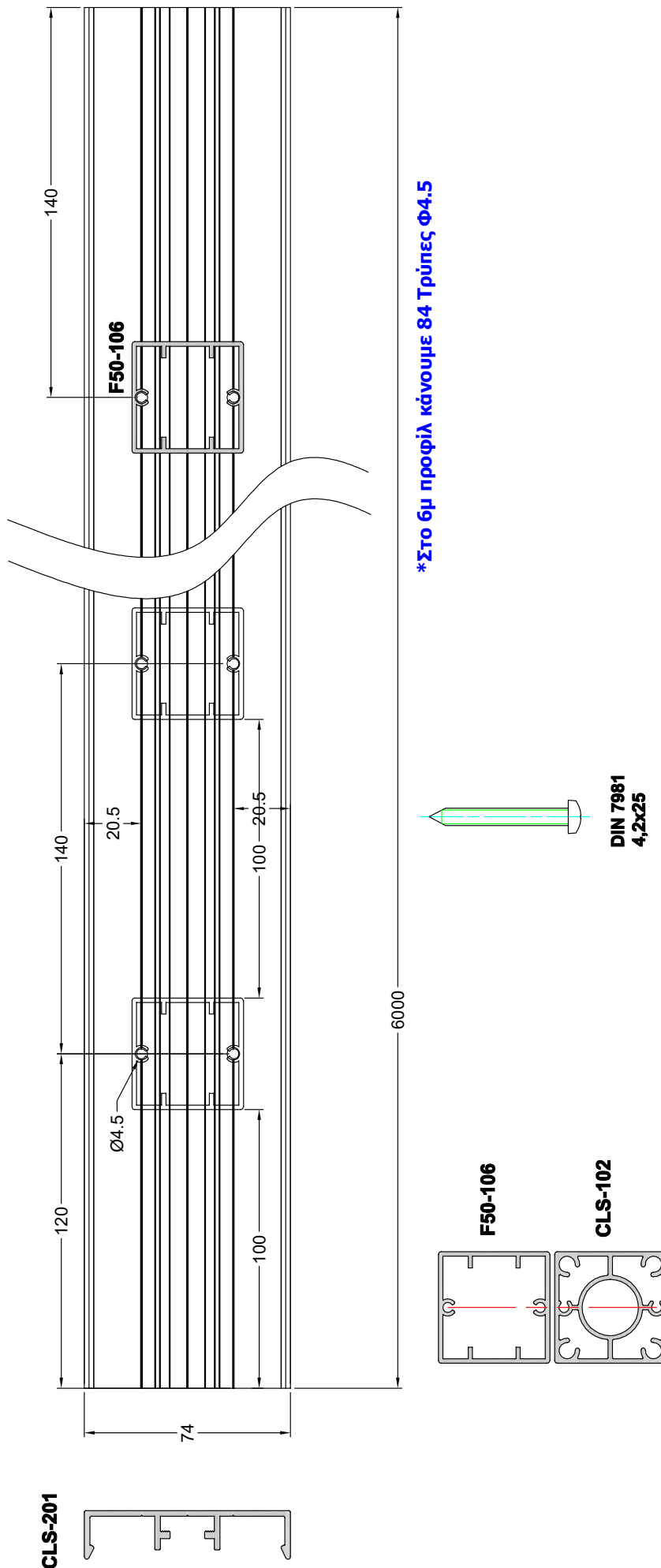

FSN-221_FSN-302 LINEAR HOLE CUTTINGS

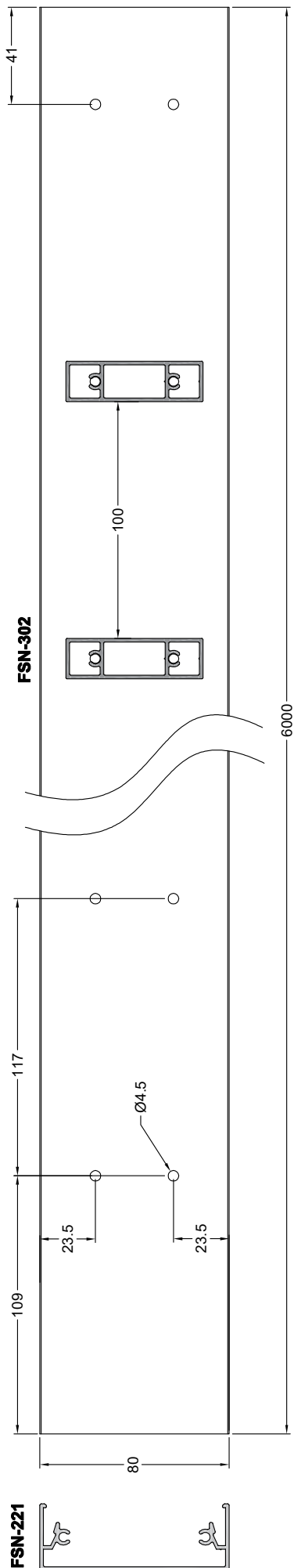

*Στο 6μ προφίλ κάνουμε 102 Τρύπες $\varnothing 4.5$



DIN 7981
4,2x25

CLS-201_FSN-100 LINEAR HOLE CUTTINGS

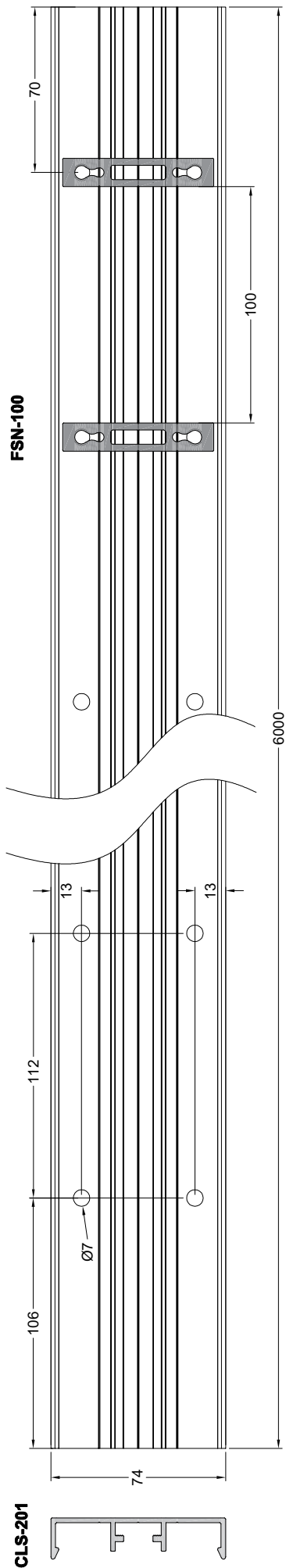

* Στο 6μ προφίλ κάνουμε 106 Τρύπες Φ7

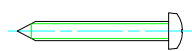

DIN 7981
6,3x25

CLS-3K1_CLS-102 LINEAR HOLE CUTTINGS

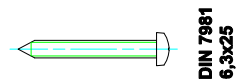
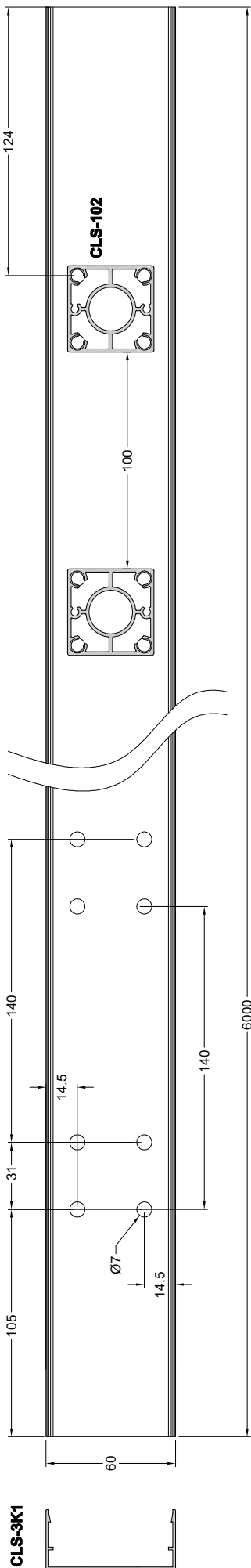

* Στο 6μ προφίλ κάνουμε 84 Τρύπες Φ7

CLS-301_CLS-102 LINEAR HOLE CUTTINGS

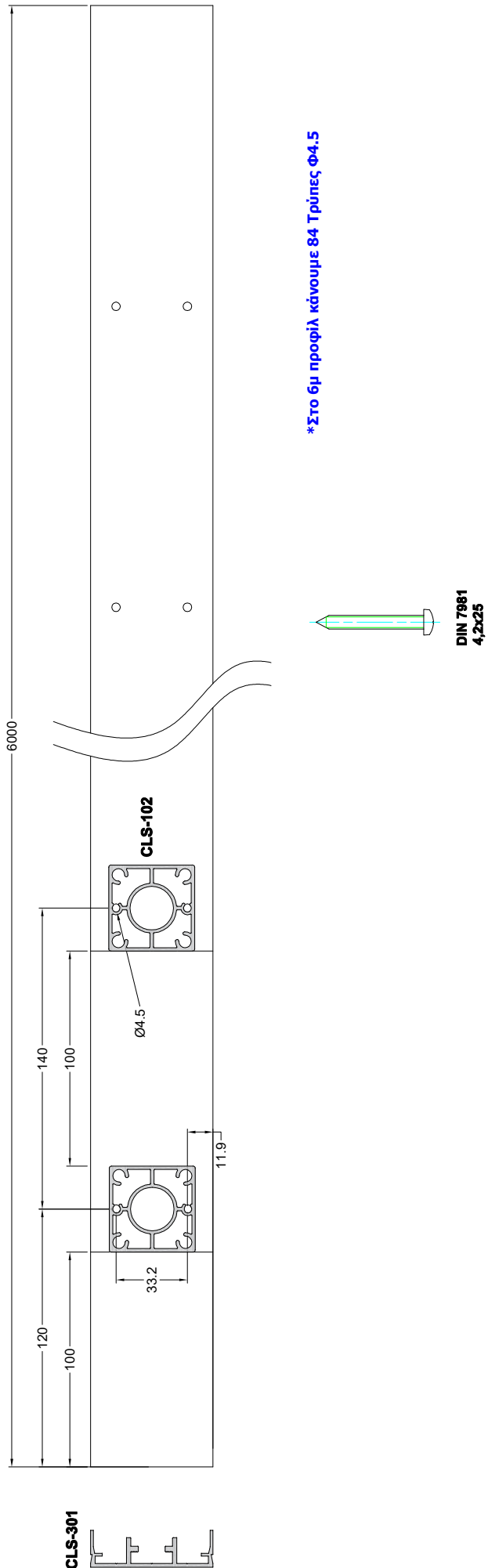

CLS-3K1_F50-106_CLS-102 LINEAR HOLE CUTTINGS

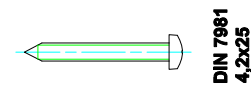
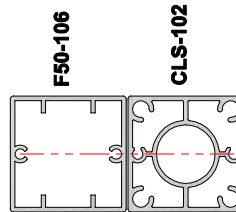
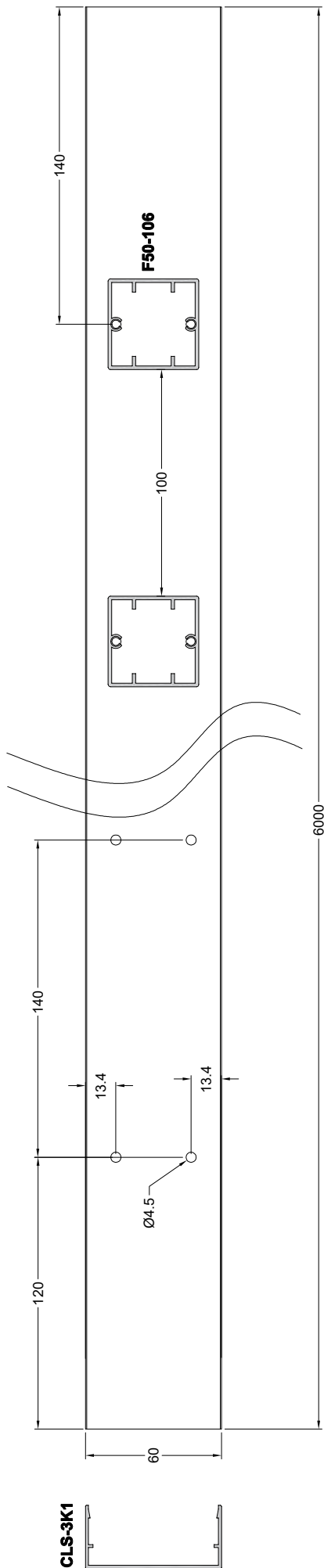

* Στο 6μ προφίλ κάνουμε 84 Τρύπες Ø4.5

CLS-301_F50-106_CLS-102 LINEAR HOLE CUTTINGS

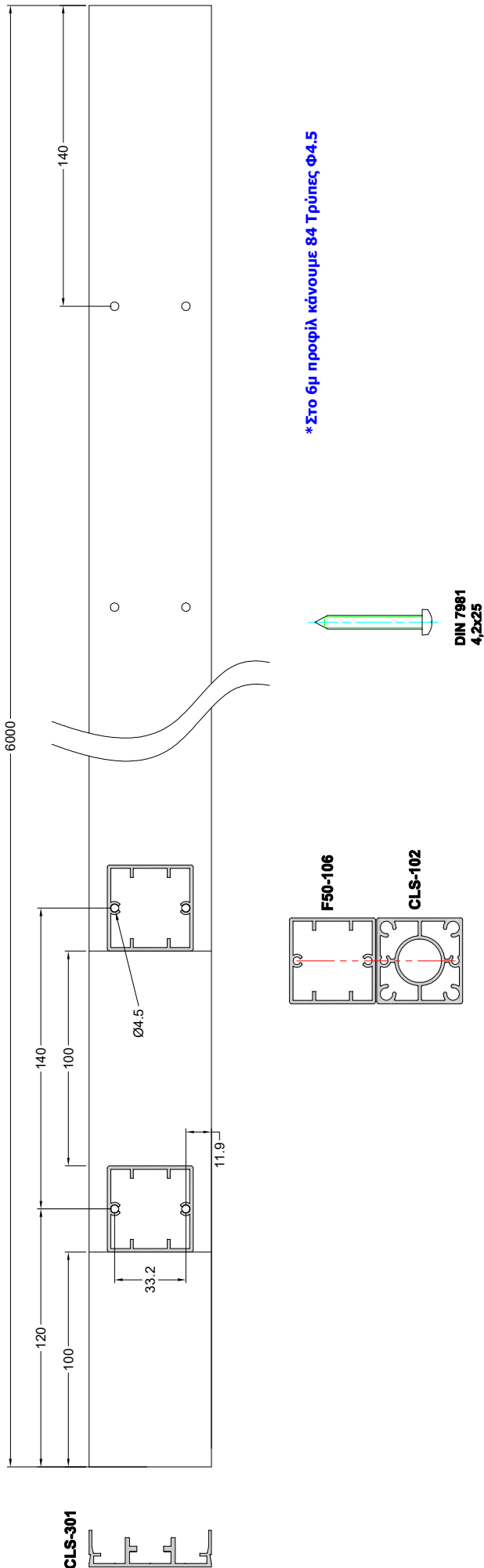

CLS-3K1_FSN-302 LINEAR HOLE CUTTINGS

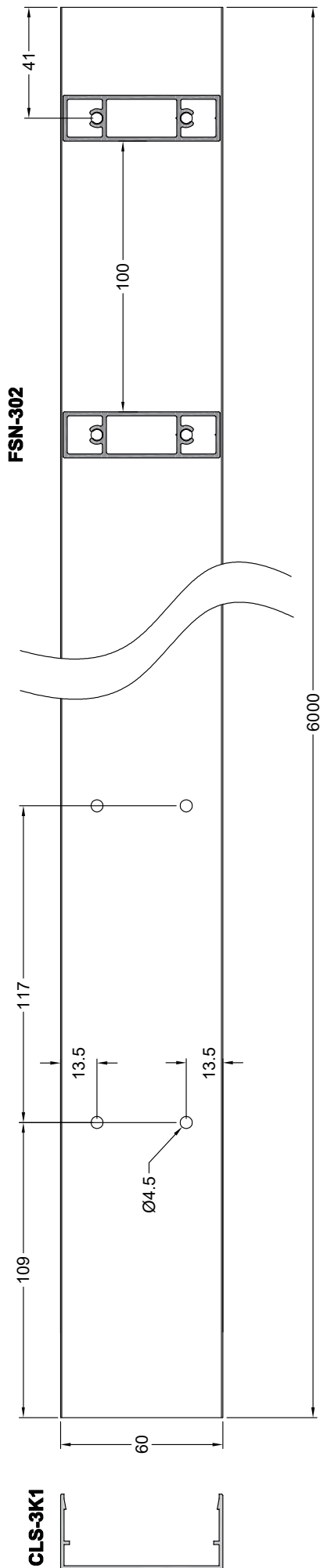

* Στο 6m προφίλ κάνουμε 102 Τρύπες Φ4.5

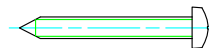

DIN 7981
4,2x25

CLS-301_FSN-302 LINEAR HOLE CUTTINGS

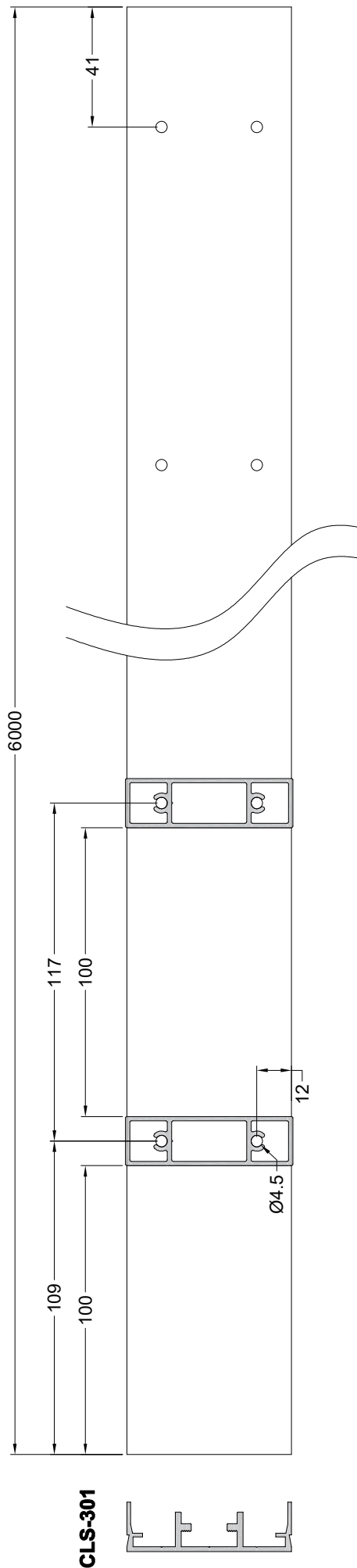

CLS-301

*** Στο 6μ προφίλ κάνουμε 102 Τρύπες $\varnothing 4.5$**

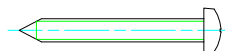

**DIN 7981
4,2x25**

CLS-201_WD-4040 LINEAR HOLE CUTTINGS

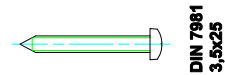
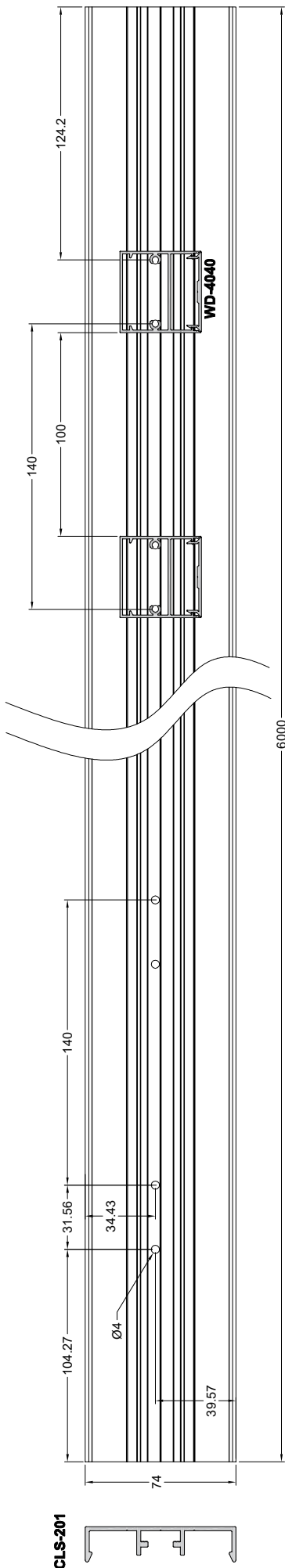

*Στο 6μ προφίλ κάνουμε 84 Τρύπες $\varnothing 4$

FSN-911_FSN-106 LINEAR HOLE CUTTINGS

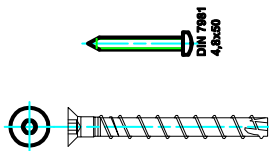
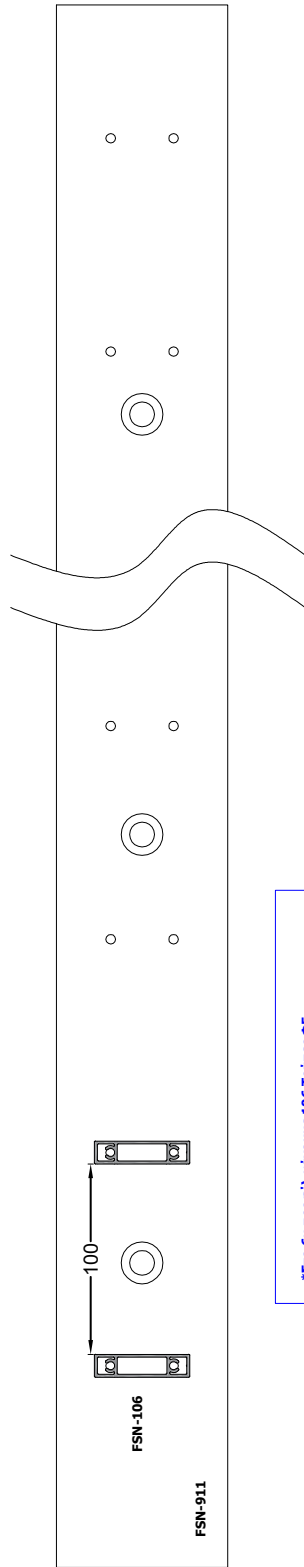

*Στο 6μ προφίλ κάνουμε 106 Τρύπες Φ5
 *Στο 6μ προφίλ κάνουμε 26 Φρέζαρες Τρύπες Φ13/Φ22

EBM-10120G/2

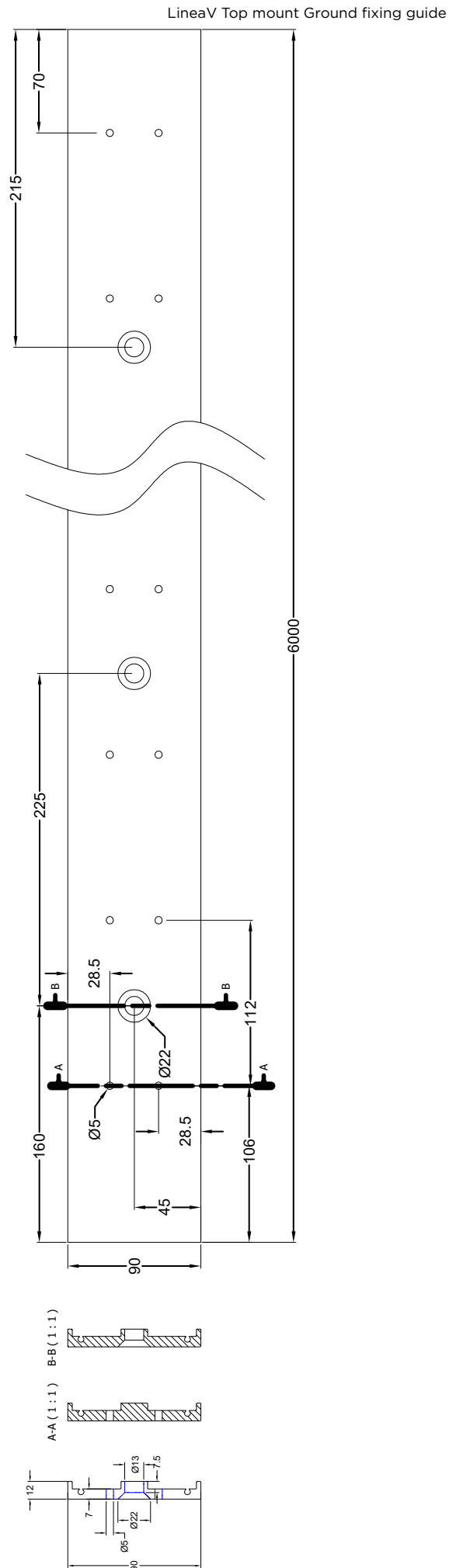

CLS-201_FSN-106 LINEAR HOLE CUTTINGS

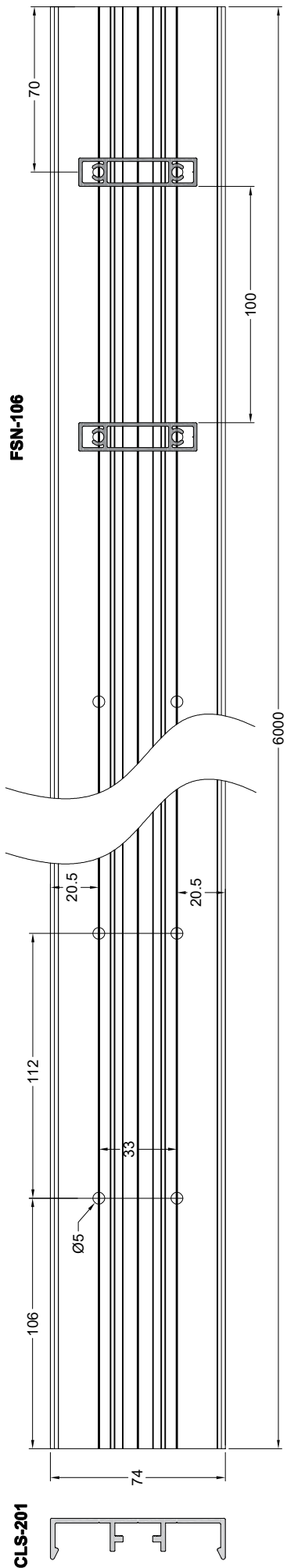

* Στο 6μ προφίλ κάνουμε 106 Τρύπες Φ5

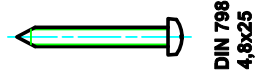

DIN 7981
4.8x25

FSN-221_FSN-106 LINEAR HOLE CUTTINGS

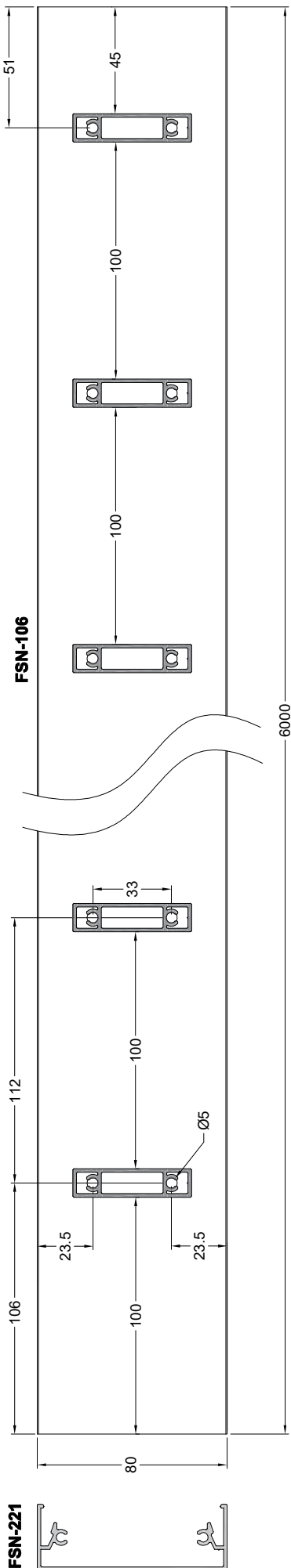

* Στο 6μ προφίλ κάνουμε 106 Τρύπες Φ5



DIN 7981
4,8x25

LineaV

Balustrades: Side Mount



1

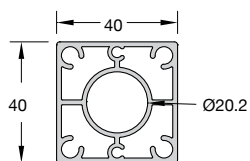

Code / Κωδικός **CLS-102**
 Weight / Βάρος 1245 gr/m
 Length / Μήκος 6 m



2

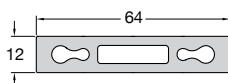

Code / Κωδικός **FSN-100**
 Weight / Βάρος 1442 gr/m
 Length / Μήκος 6 m



3

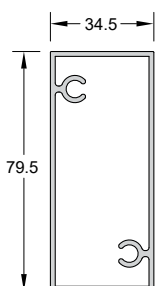

Code / Κωδικός **FSN-401**
 Weight / Βάρος 1142 gr/m
 Length / Μήκος 6 m



4

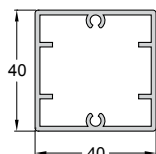

Code / Κωδικός **F50-106**
 Weight / Βάρος 794 gr/m
 Length / Μήκος 6 m



5

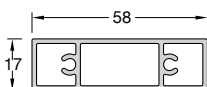

Code / Κωδικός **FSN-302**
 Weight / Βάρος 781 gr/m
 Length / Μήκος 6 m



6

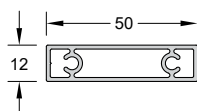

Code / Κωδικός **FSN-106**
 Weight / Βάρος 540 gr/m
 Length / Μήκος 6 m



Side Mount Typical Assembly - FSN 106/ FSN-912

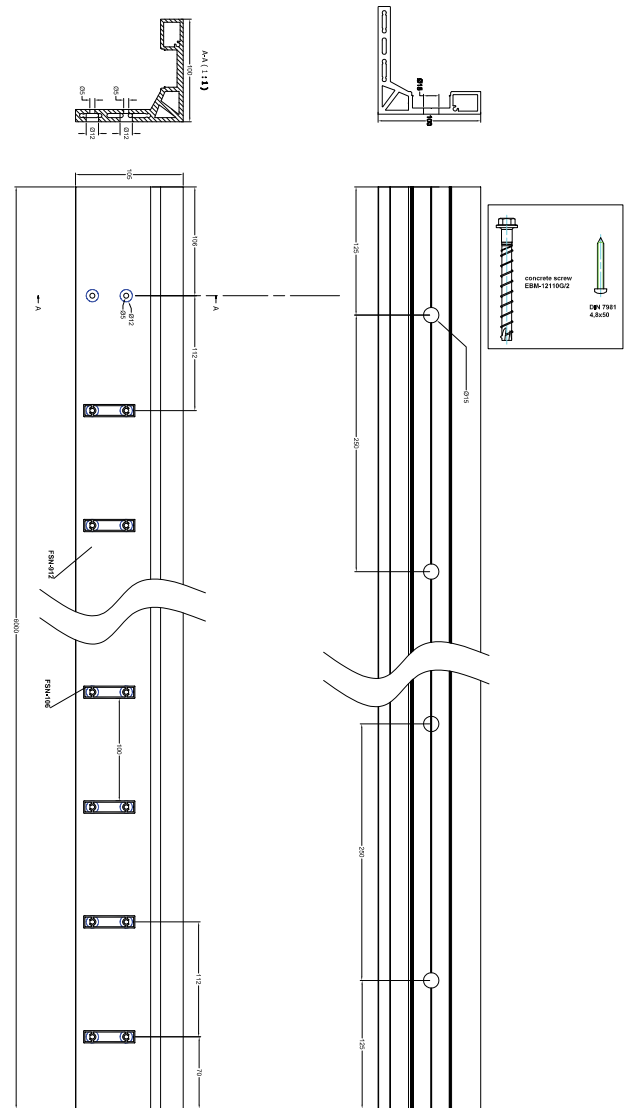
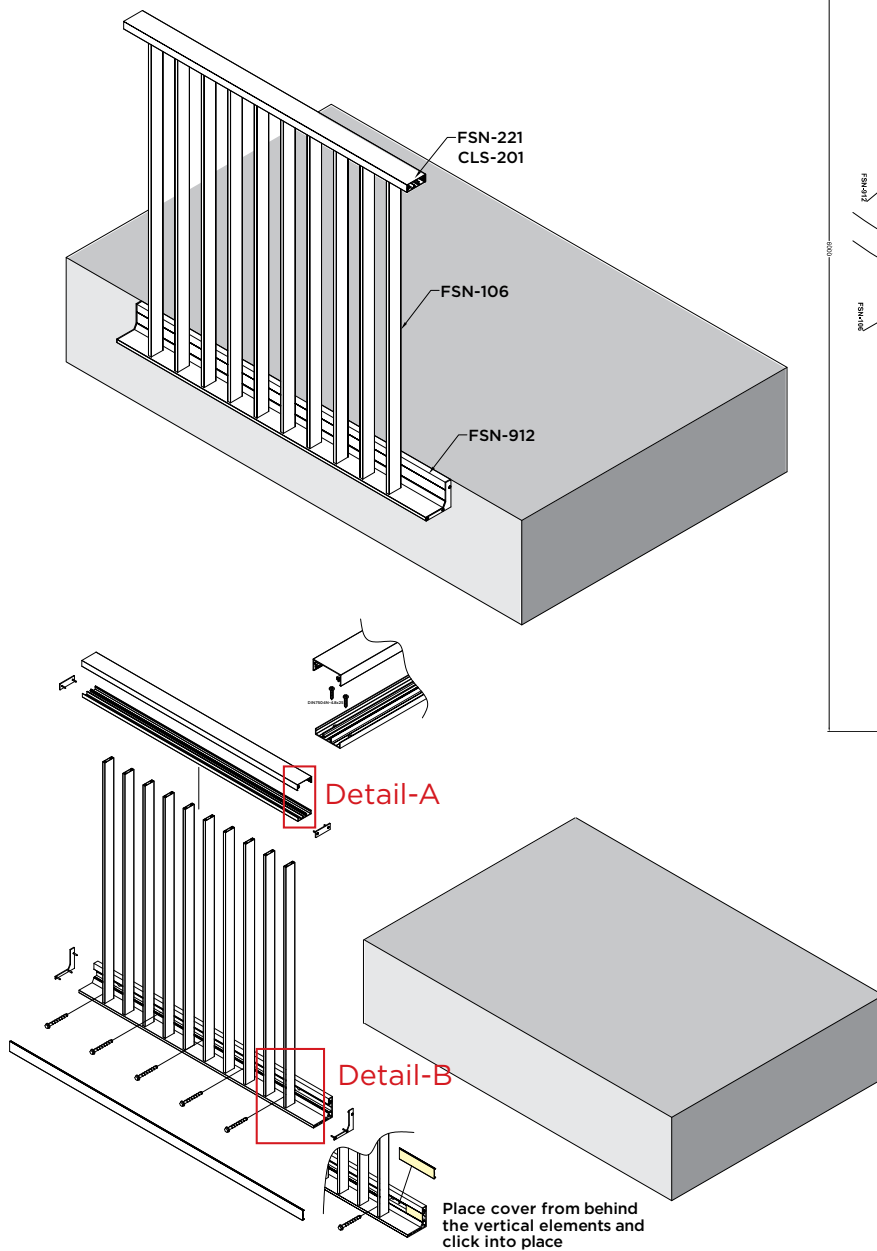

New Fusion Line Type:
Side Mount FSN-106
(SIDE MOUNT UNIFORM BASE)

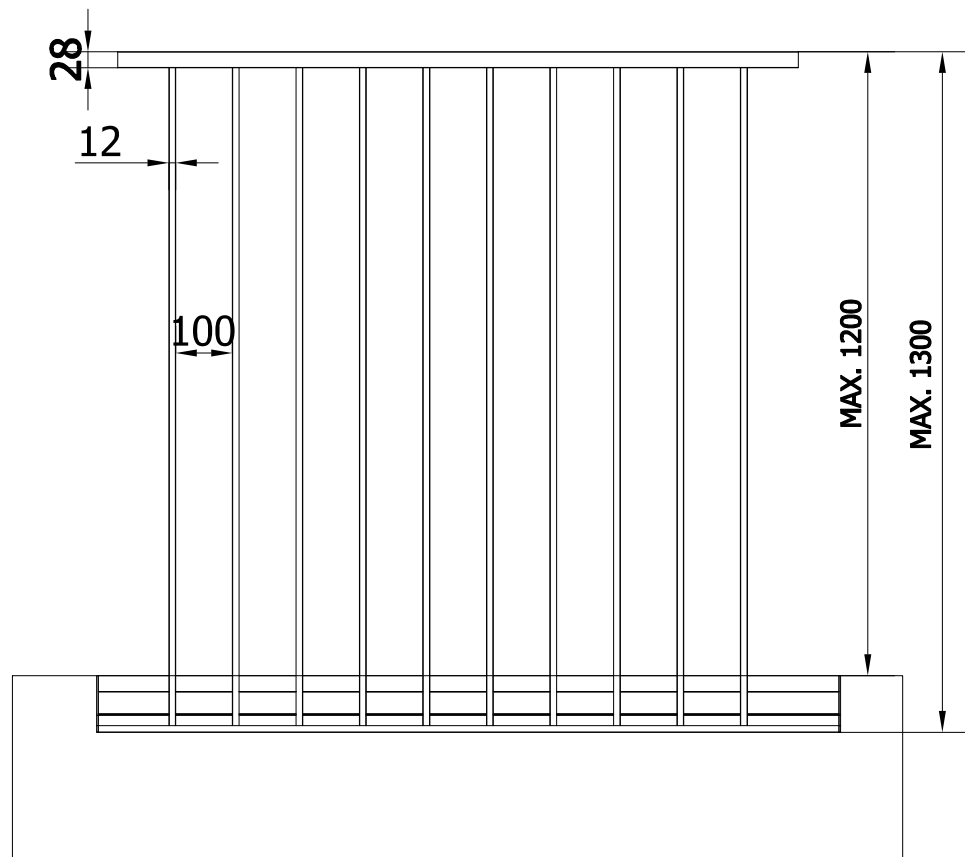
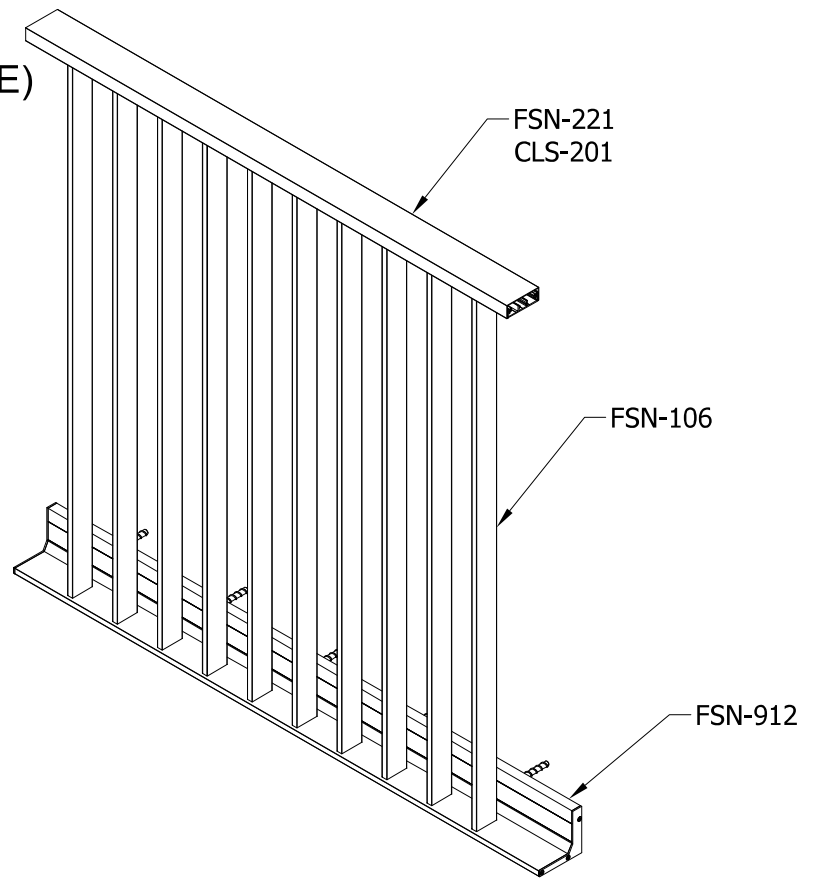

New Fusion Line Type: Side Mount FSN-302

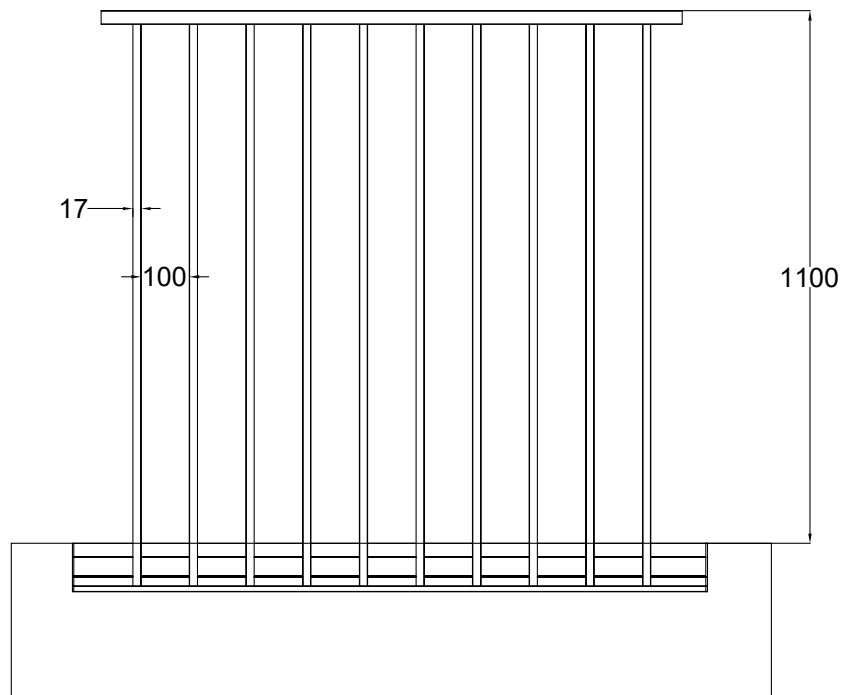
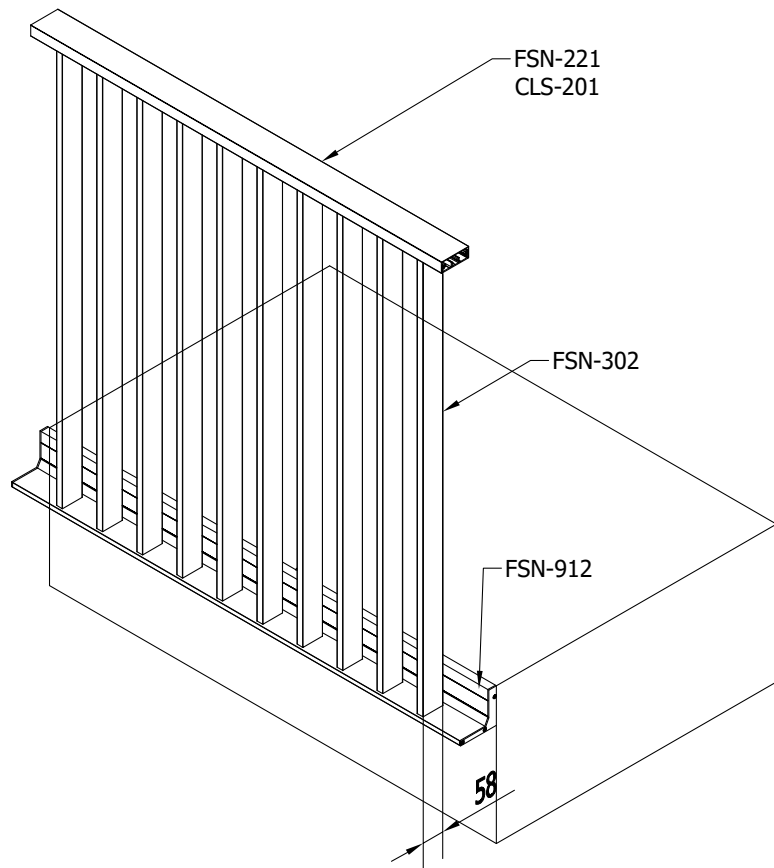

New Fusion Line Type: Side Mount FSN-100

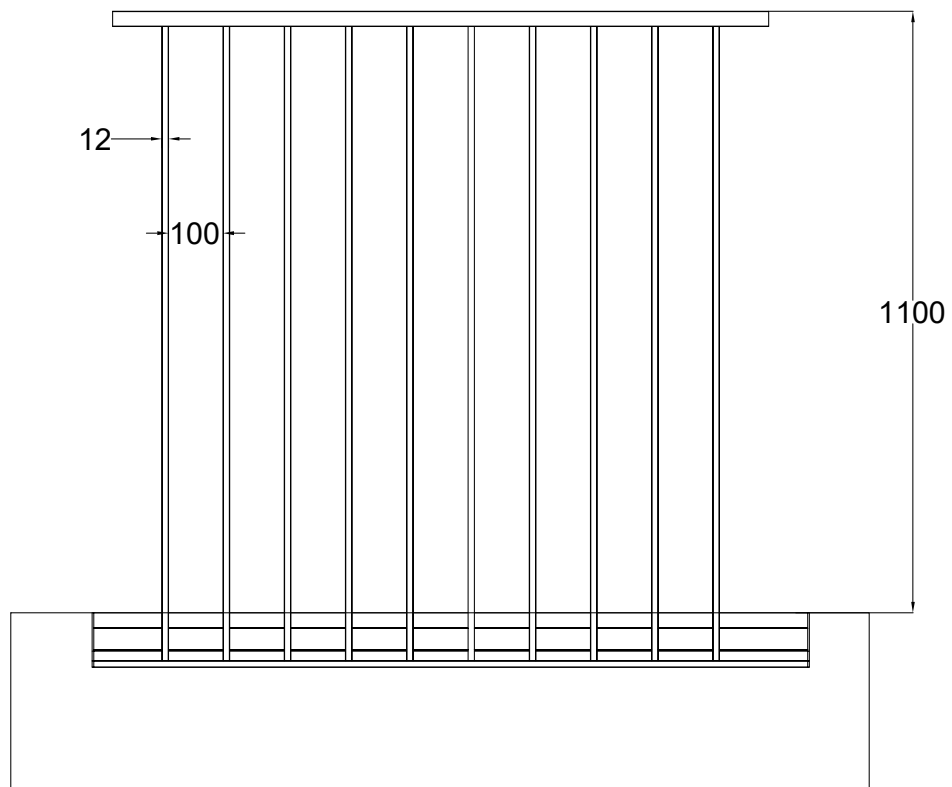
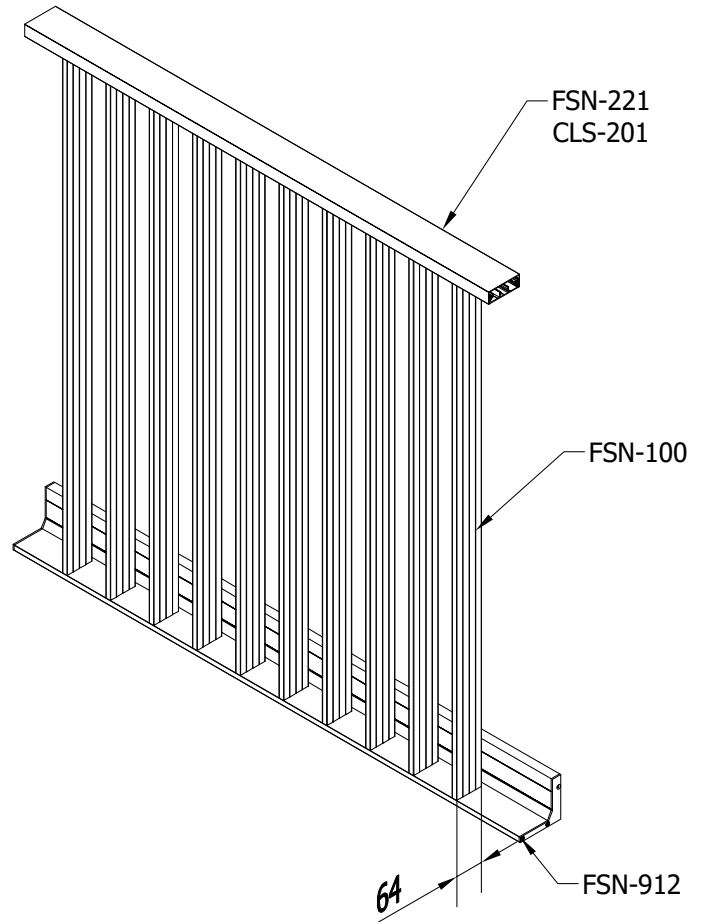

New Fusion Line Type: Side Mount CLS-102

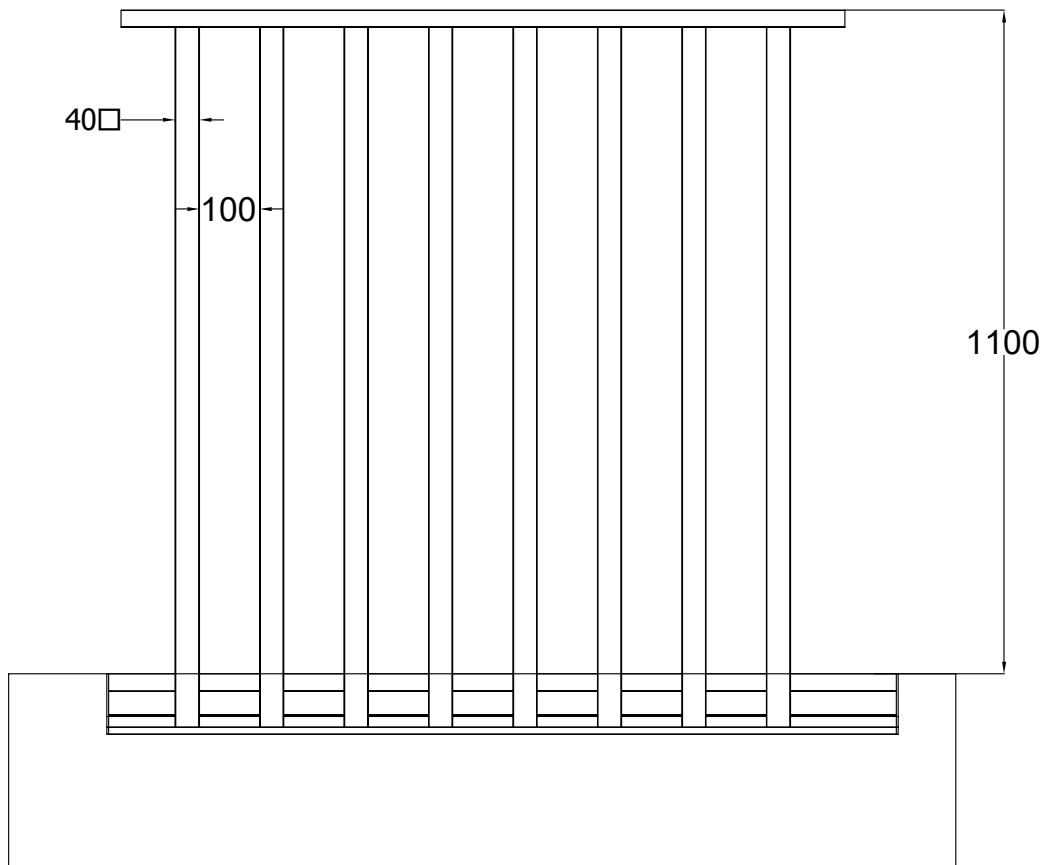
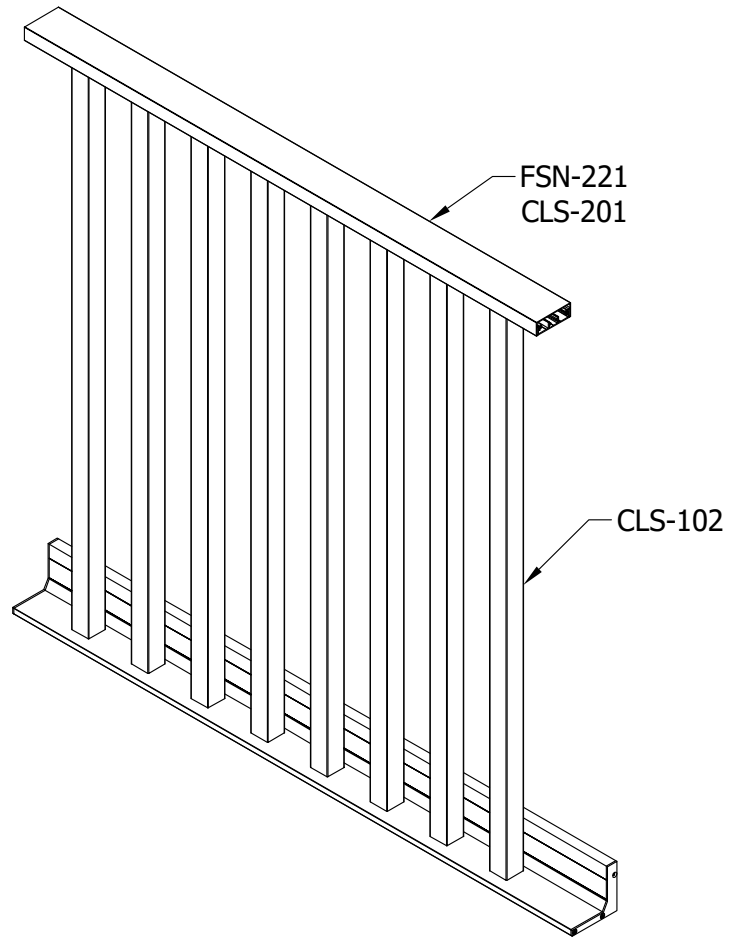

New Fusion Line Type:
Side Mount CLS-102
with WALL&DECO

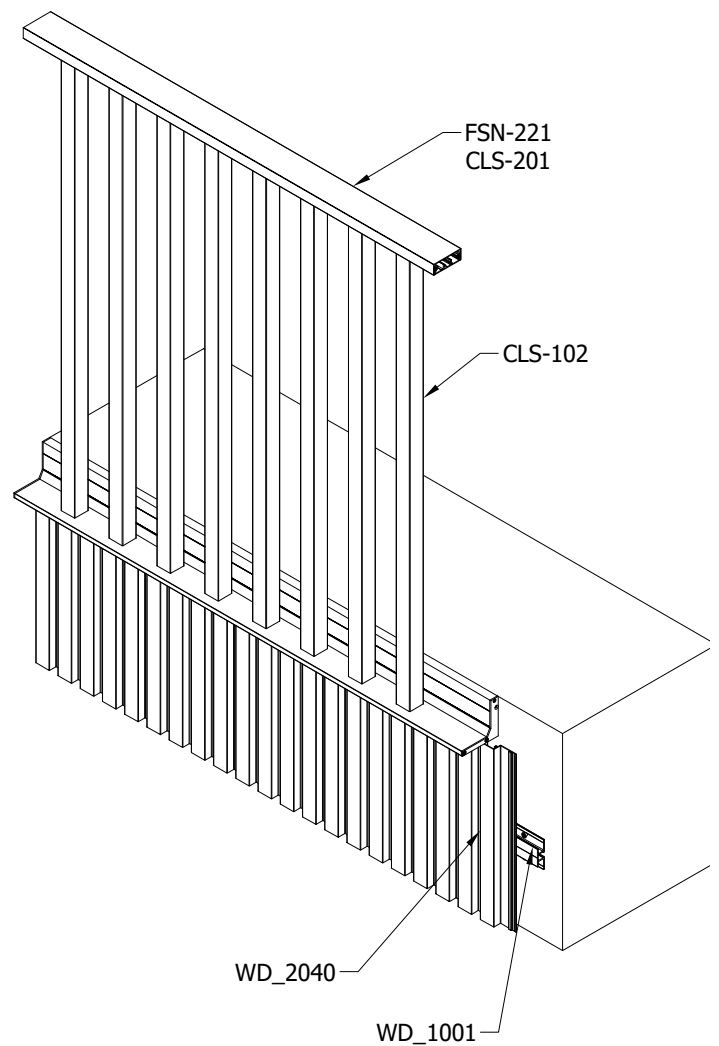
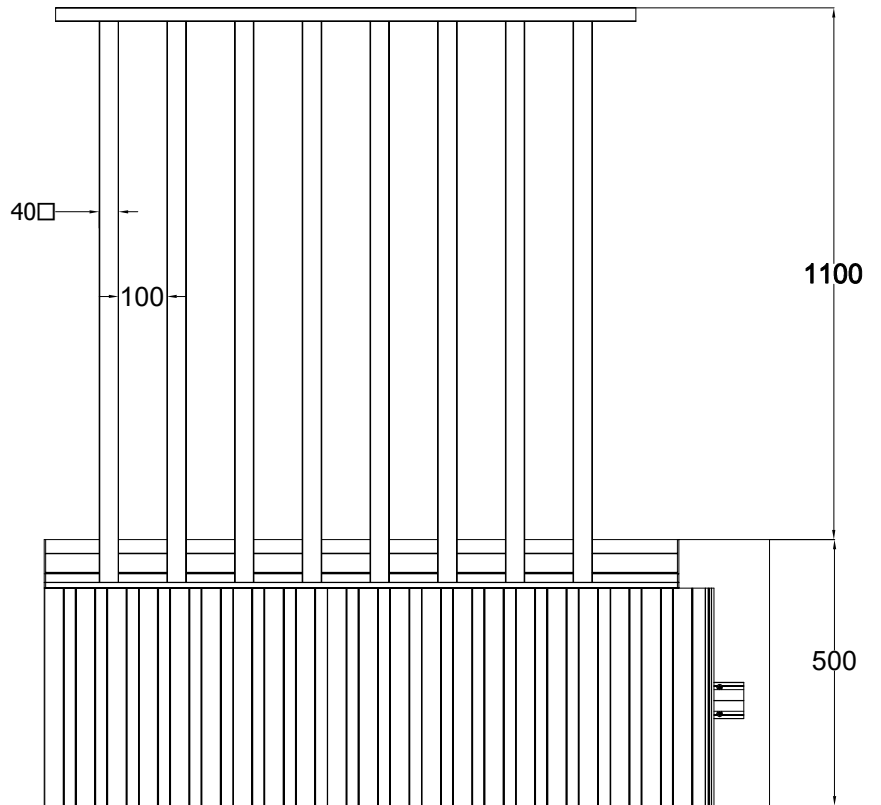

New Fusion Line Type: Side Mount FSN-401

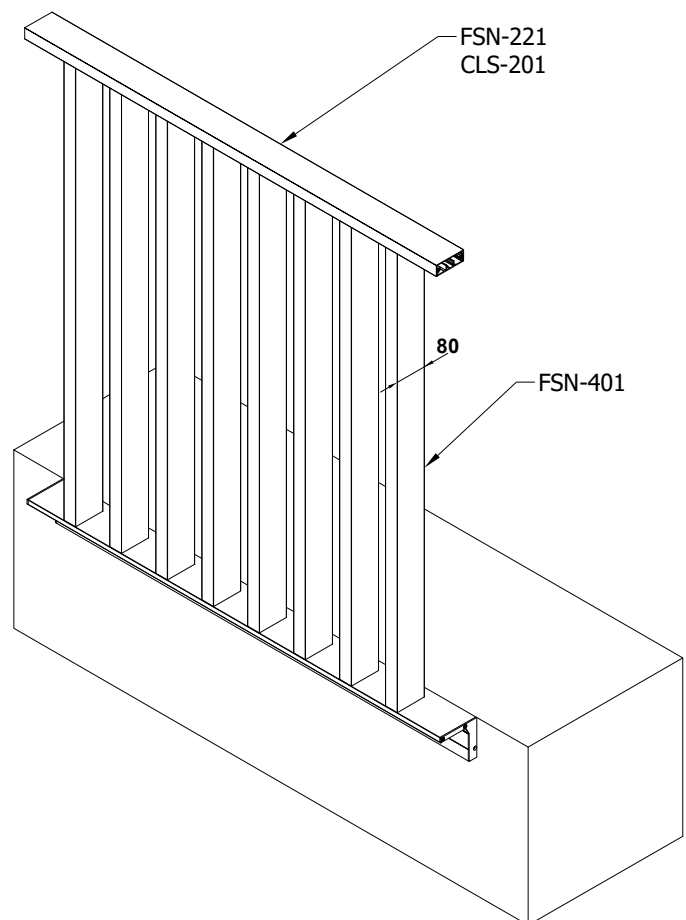
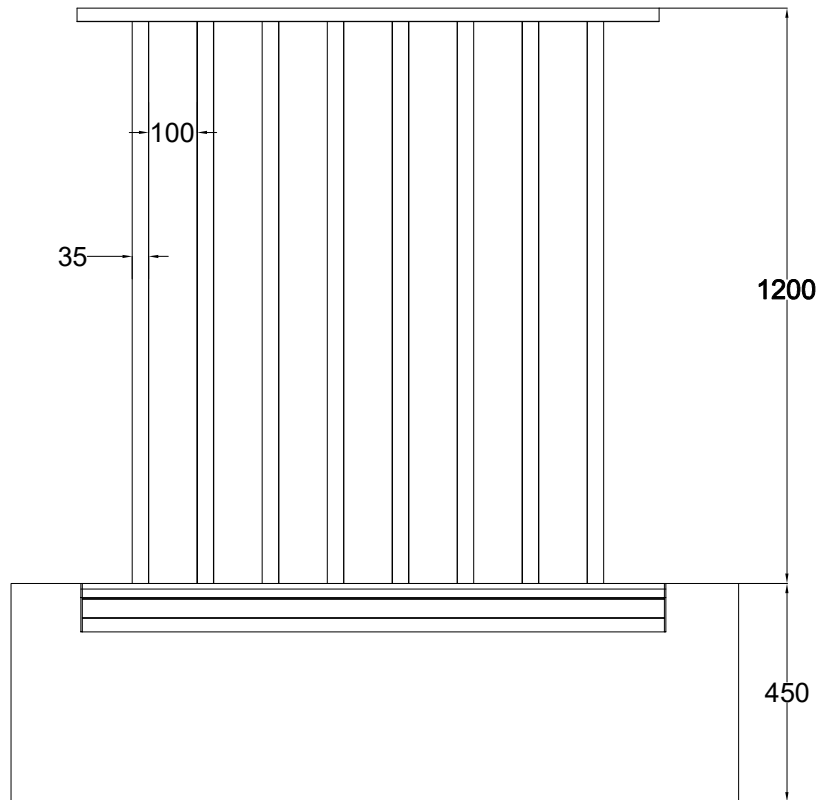

Side Mount Option with Wall & Deco - Detail Module View

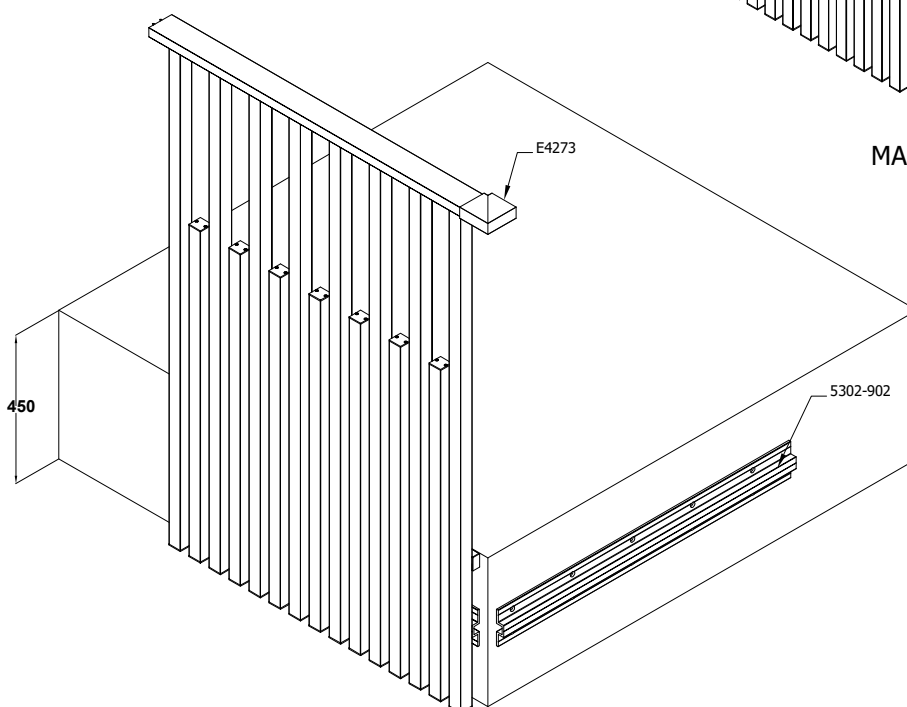
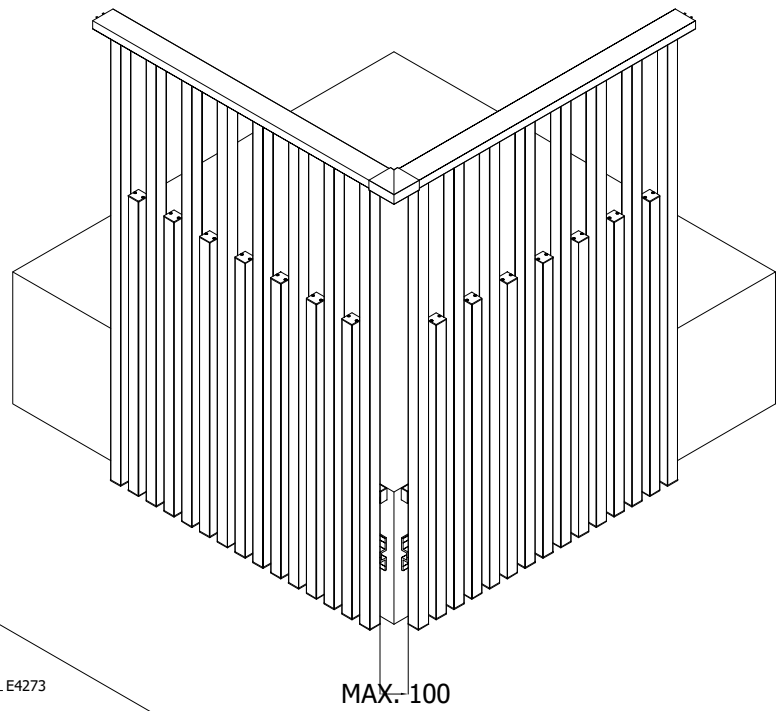
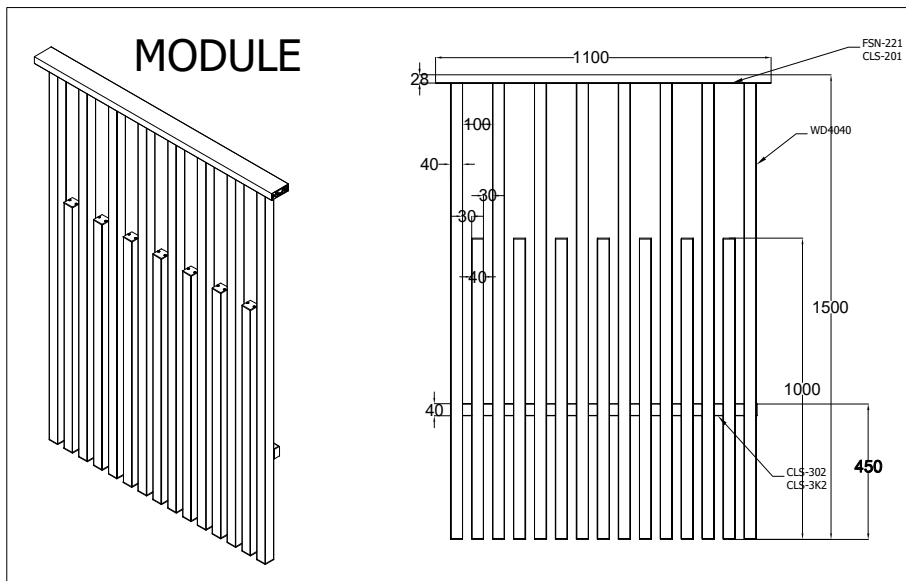

LineaV Side mount Ground fixing guide



SIDE MOUNT

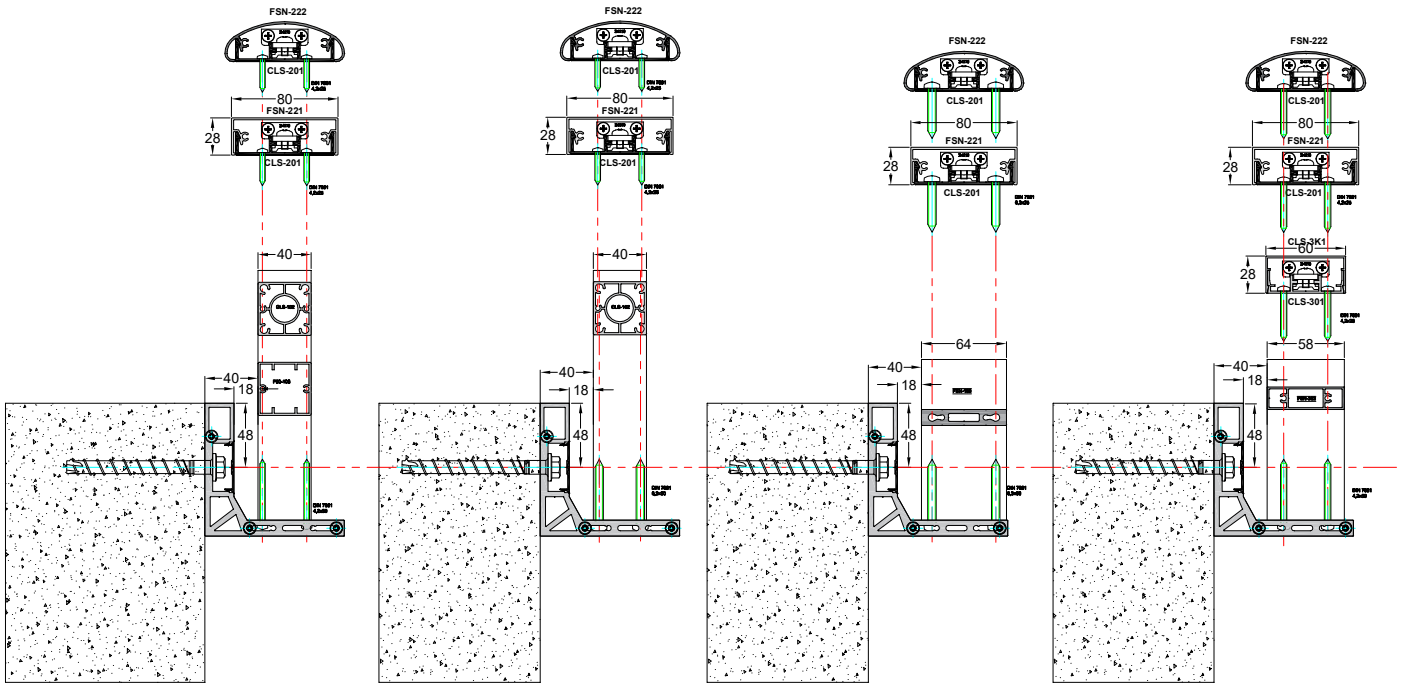

SIDE MOUNT

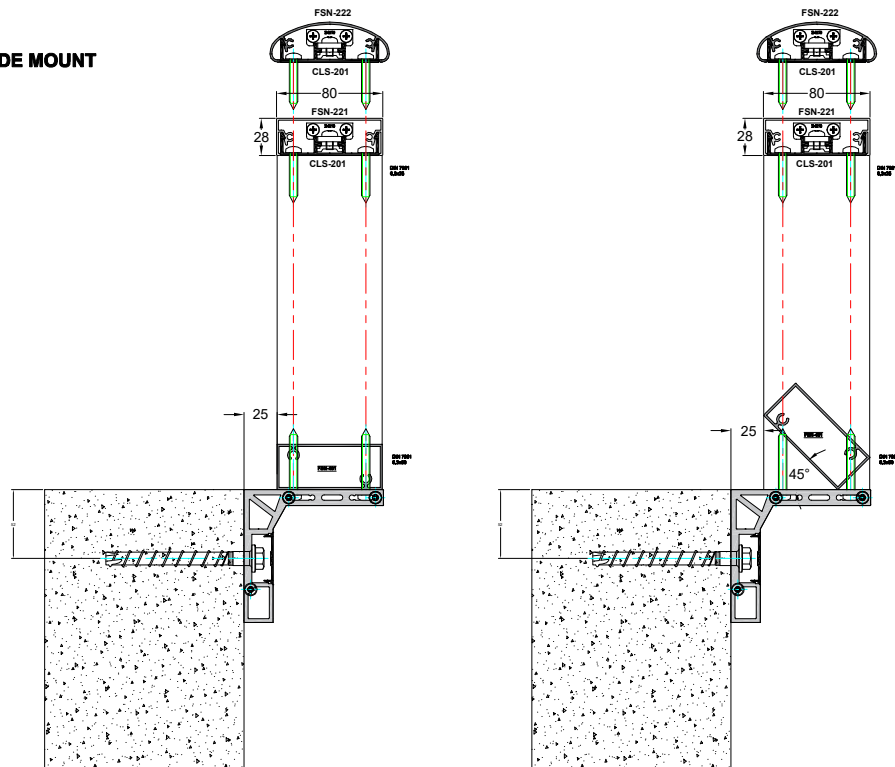

Side Mount Option with Wall & Deco

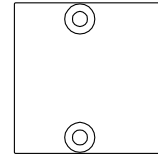

WD-4040

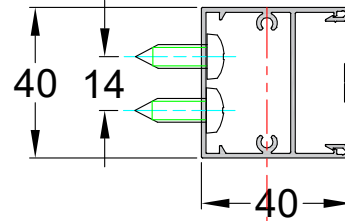

SIDE MOUNT

WD-4040

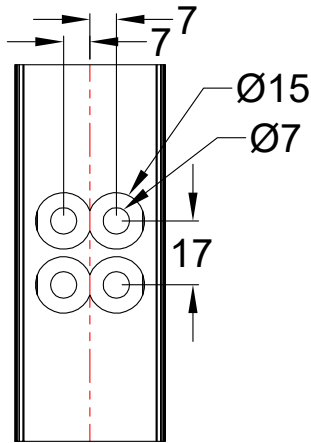
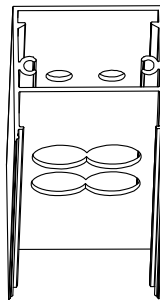

FSN-222

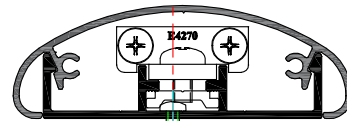

CLS-201



FSN-221



CLS-201

DIN 7981
3,5x25

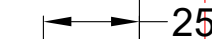

CLS-302
CLS-3K2

DIN 7981
4,6x38

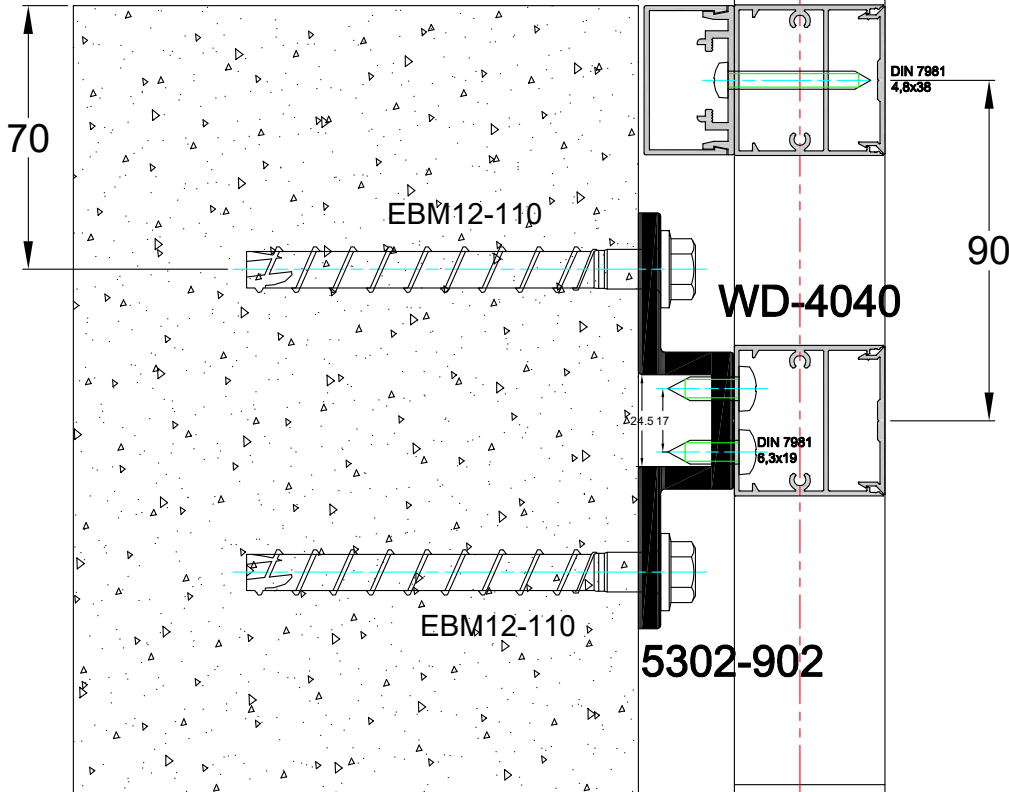

WD-4040

5302-902

FSN-912_CLS-102 SIDE MOUNT HOLE CUTTINGS

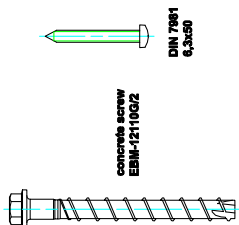
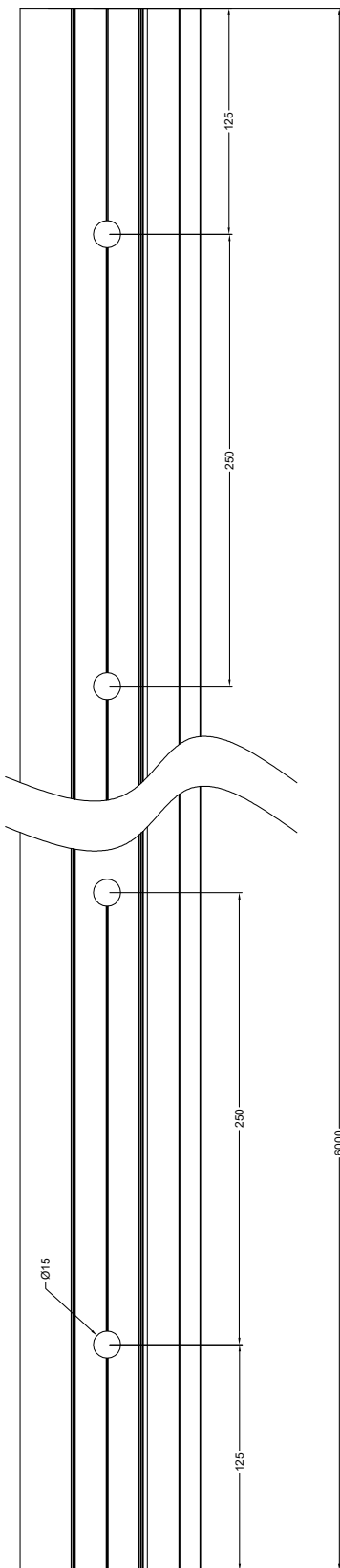

* Στο 6μ προφίλ κάνουμε 168 Τρύπες Ø7 / Ø14
 * Στο 6μ προφίλ κάνουμε 24 Τρύπες Ø15

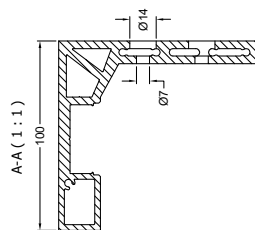
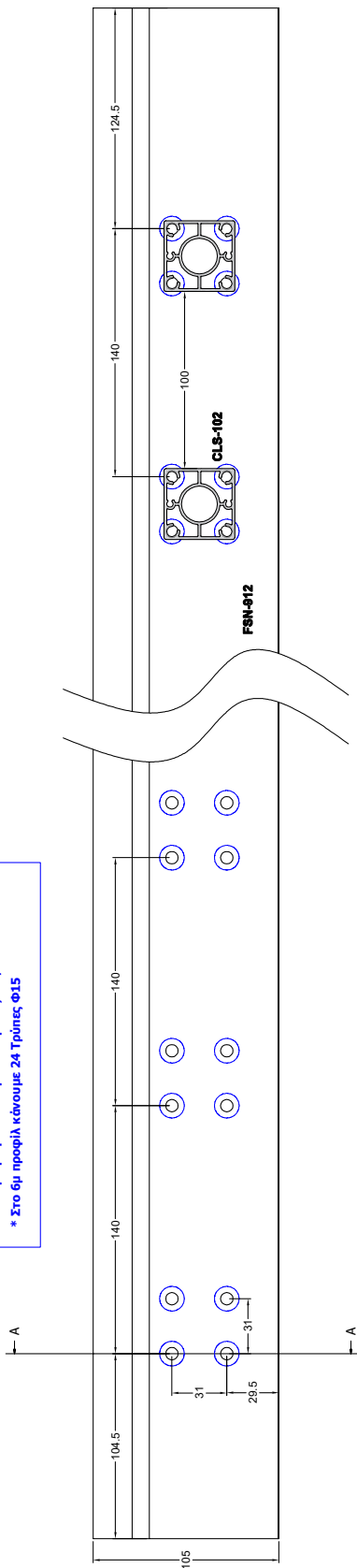

FSN-912_F50-106 SIDE MOUNT HOLE CUTTINGS

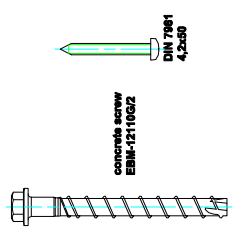
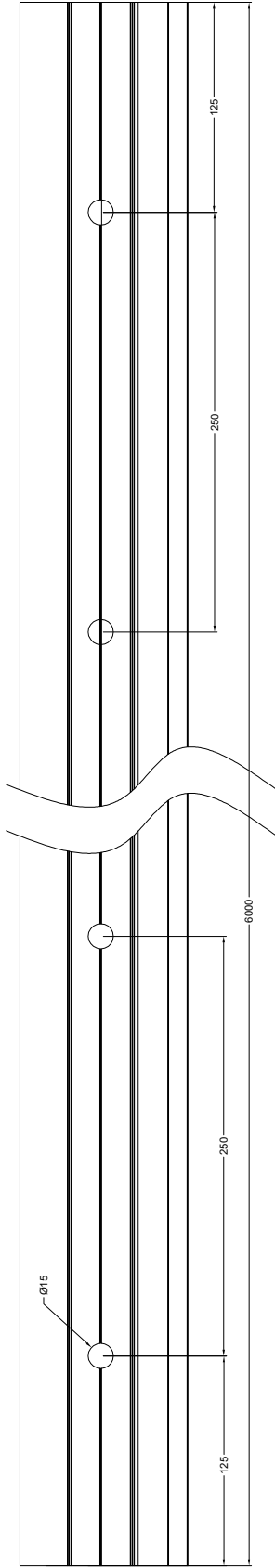

* Στο 6μ προφίλ κάνουμε 84 Τρύπες Ø4.5 / Ø10
 + Στο 6μ προφίλ κάνουμε 24 Τρύπες Ø15

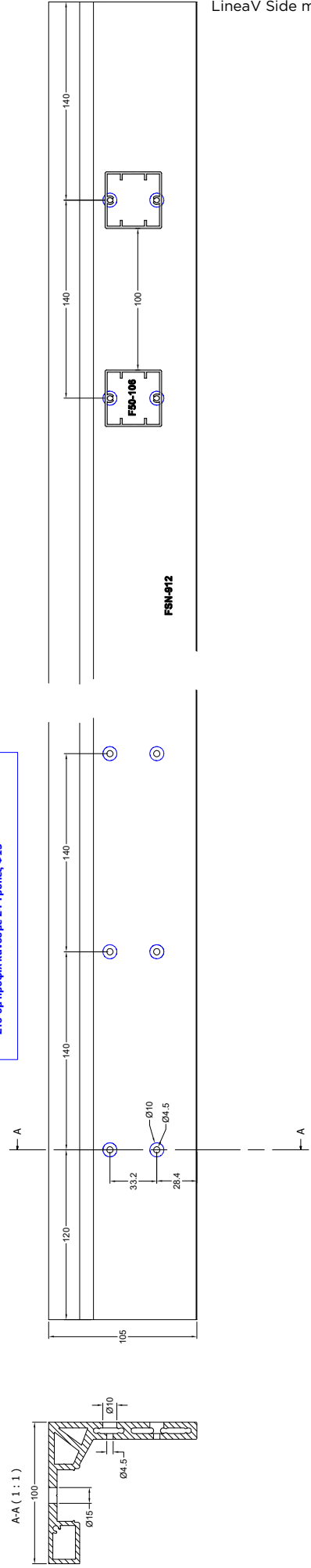

FSN-912_FSN-100 SIDE MOUNT HOLE CUTTINGS

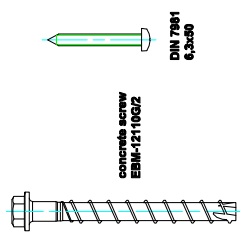
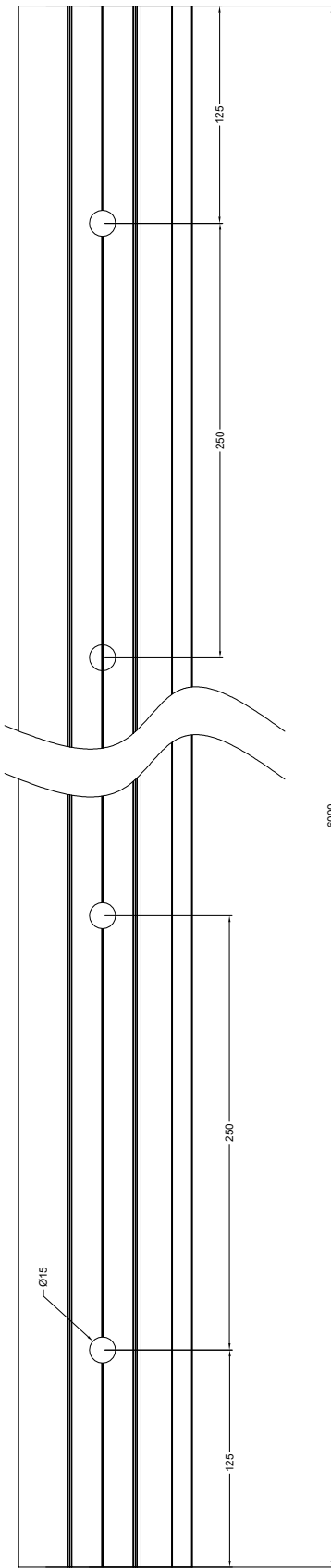

* Στο 6μ προφίλ κάνουμε 106 Τρύπες Φ7 / Φ14
 * Στο 6μ προφίλ κάνουμε 24 Τρύπες Φ15

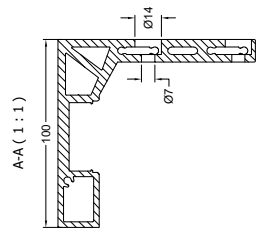
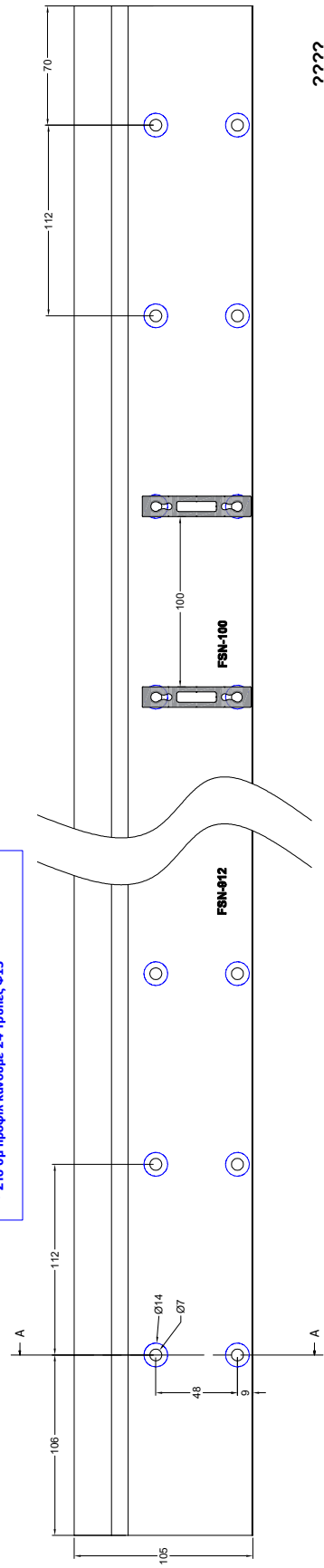

????

FSN-912_FSN-302 SIDE MOUNT HOLE CUTTINGS

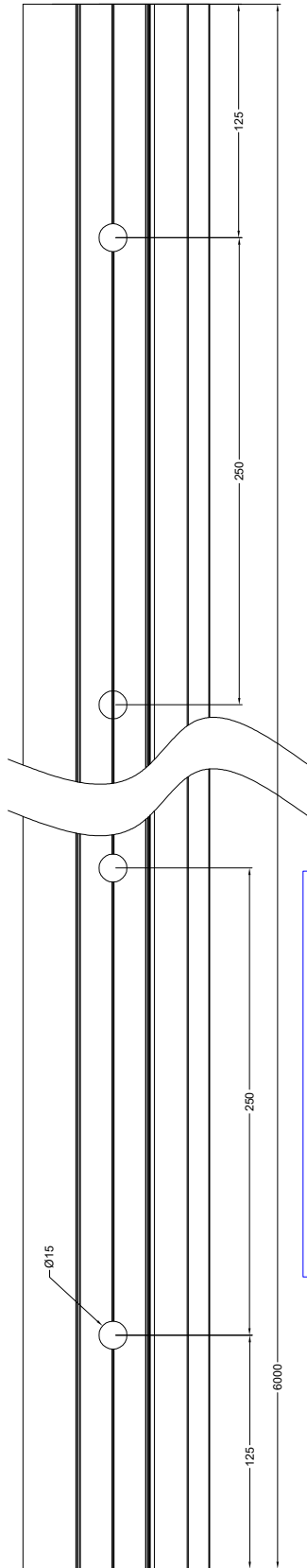

* Στο 6μ προφίλ κάνουμε 102 Τρύπες Ø4.5 / Ø10
 * Στο 6μ προφίλ κάνουμε 24 Τρύπες Ø15

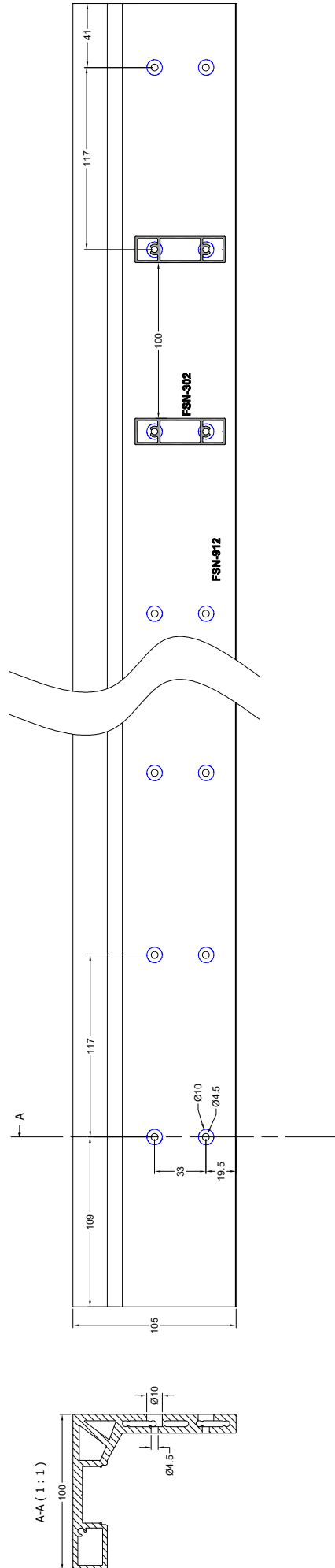
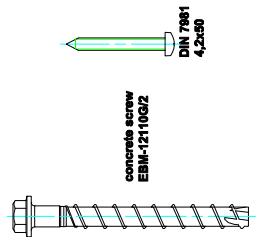

FSN-912_FSN-401_45deg_SIDE MOUNT HOLE CUTTINGS

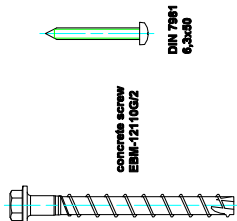
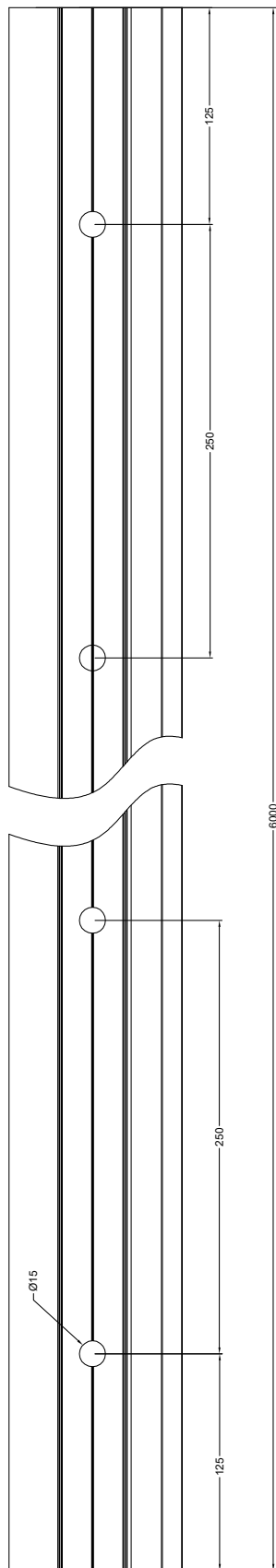

* Στο 6μ προφίλ κάνουμε 154 Τρύπες Φ7 / Φ14
 * Στο 6μ προφίλ κάνουμε 24 Τρύπες Φ15

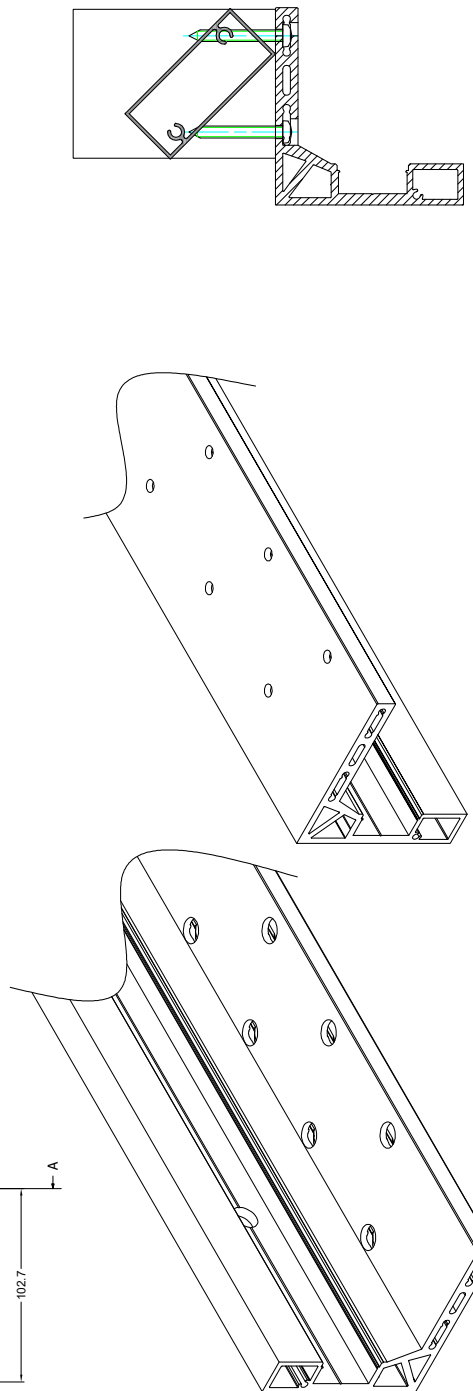
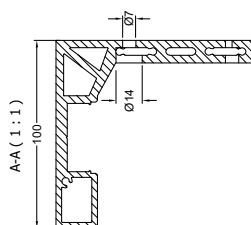
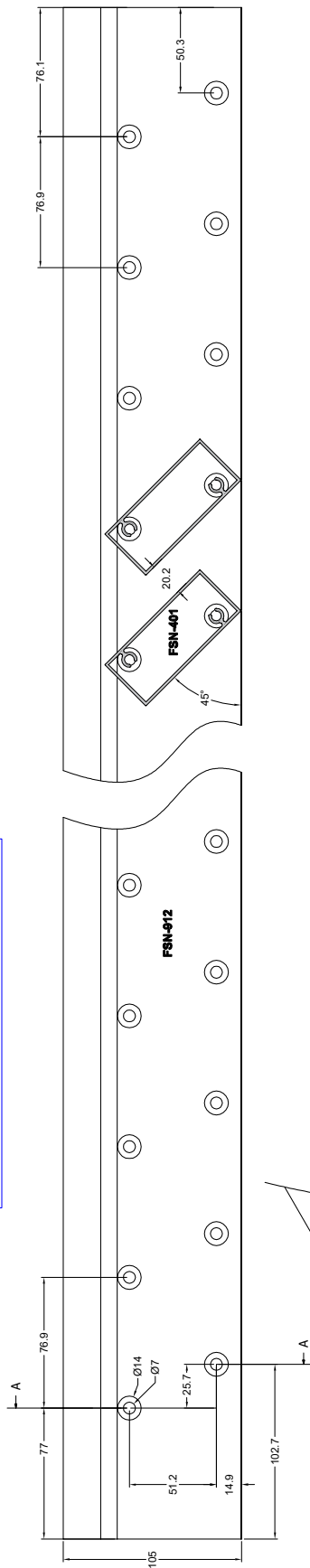

FSN-912_FSN-401 SIDE MOUNT HOLE CUTTINGS

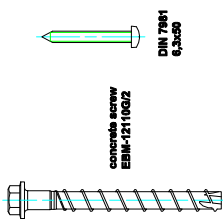
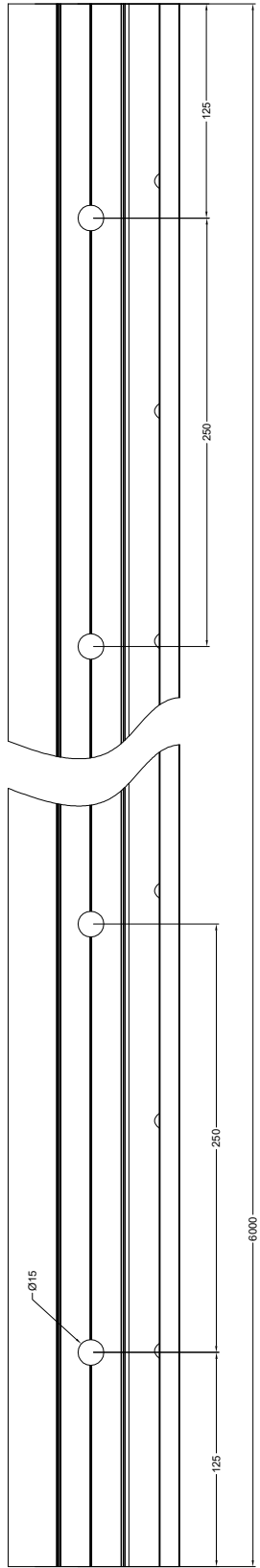

* Στο 6m προφίλ κάνουμε 88 Τρύπες Ø7 / Ø14
 * Στο 6m προφίλ κάνουμε 24 Τρύπες Ø15

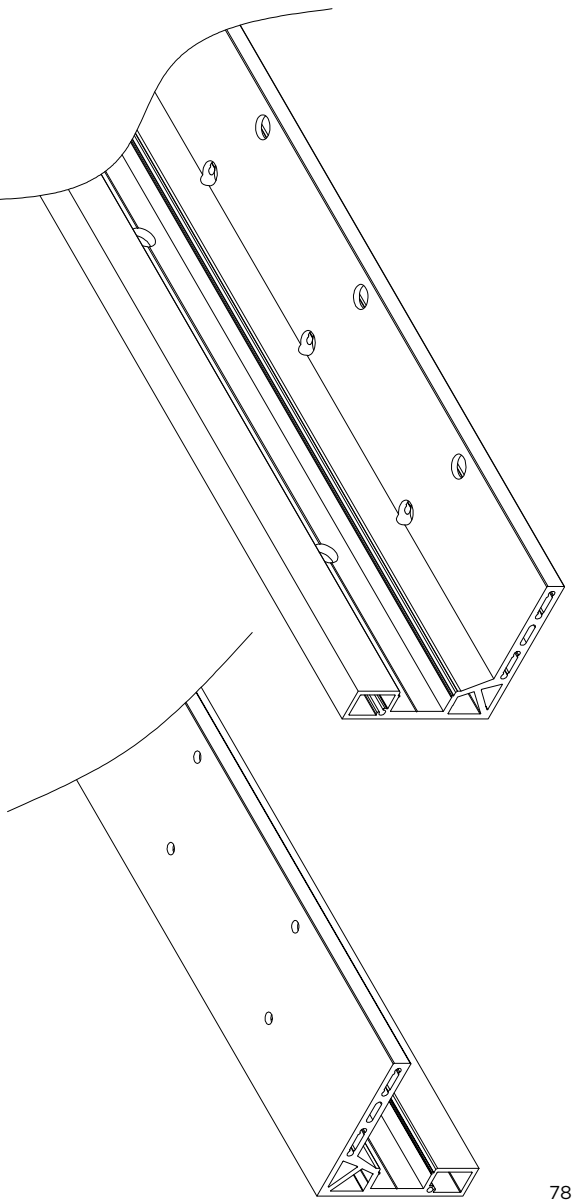
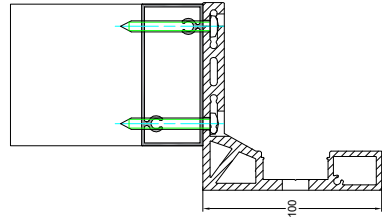
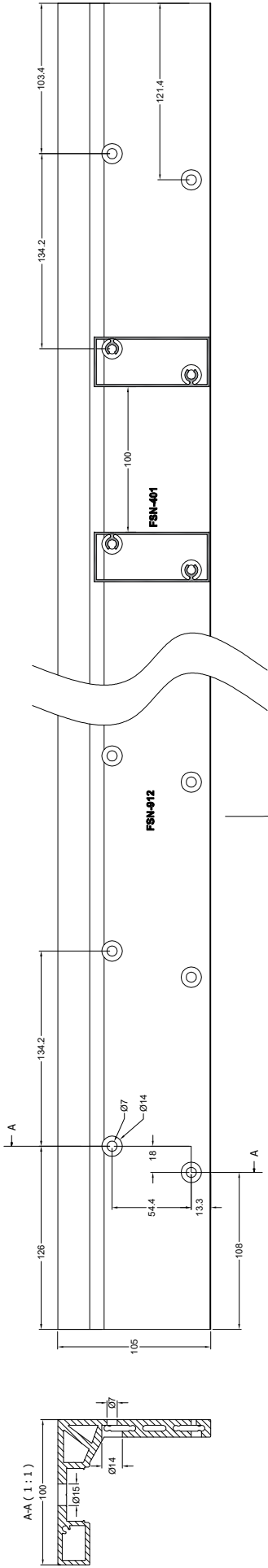

LineaV Fences



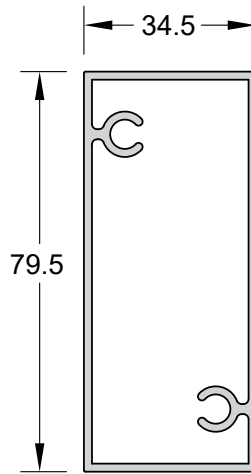

Code / Κωδικός	FSN-401
Weight / Βάρος	1142 gr/m
Length / Μήκος	6 m

1



2



3

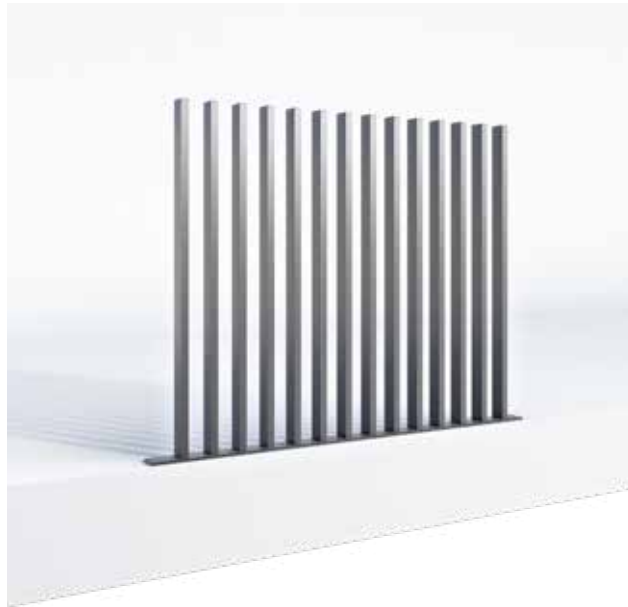

4



5



New Fusion Line Type:
Top Mount FSN-401 FENCE LINEAR LINE

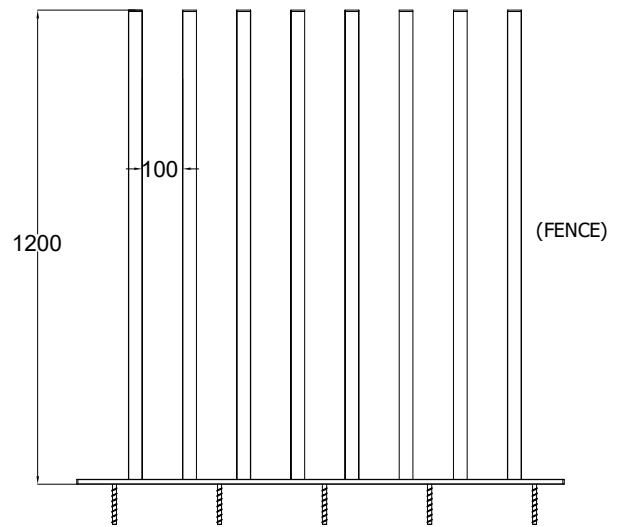
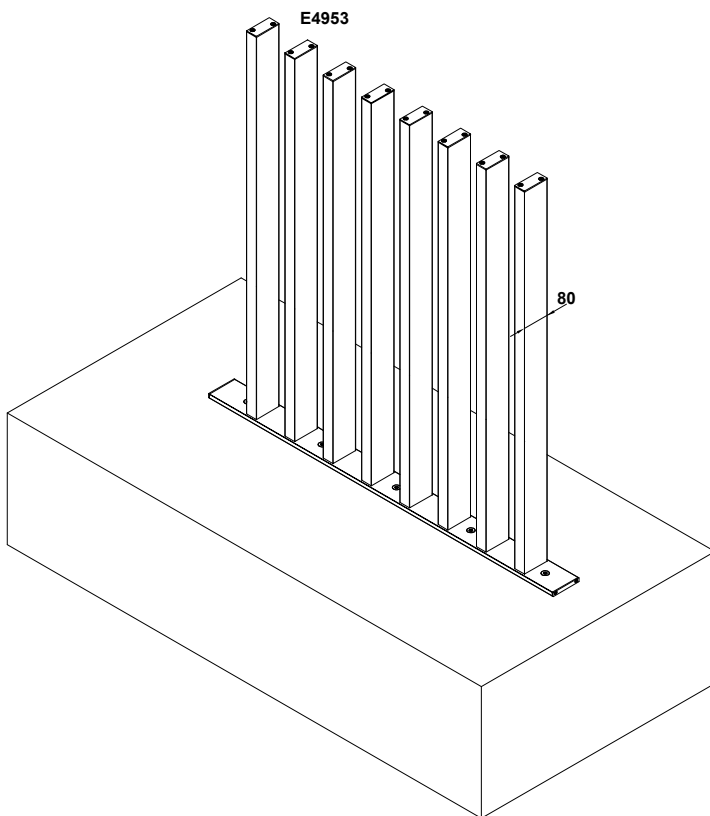



New Fusion Line Type: RIGHT ALIGNMENT - (ΔΕΞΙΑ ΔΙΑΤΑΞΗ)
 Top Mount FSN-401 FENCE ANGULAR 45° LINEAR TYPE

Top Cover (Z) - (Ταπα Ζ)

- Open Gap 20mm (ΦΩΣ 20mm) - **Top Cover (Ταπα) E4952 & FSN-911.D0U00**
- Open Gap 30mm (ΦΩΣ 30mm) - **Top Cover (Ταπα) E4958 & FSN-911.D0U10**

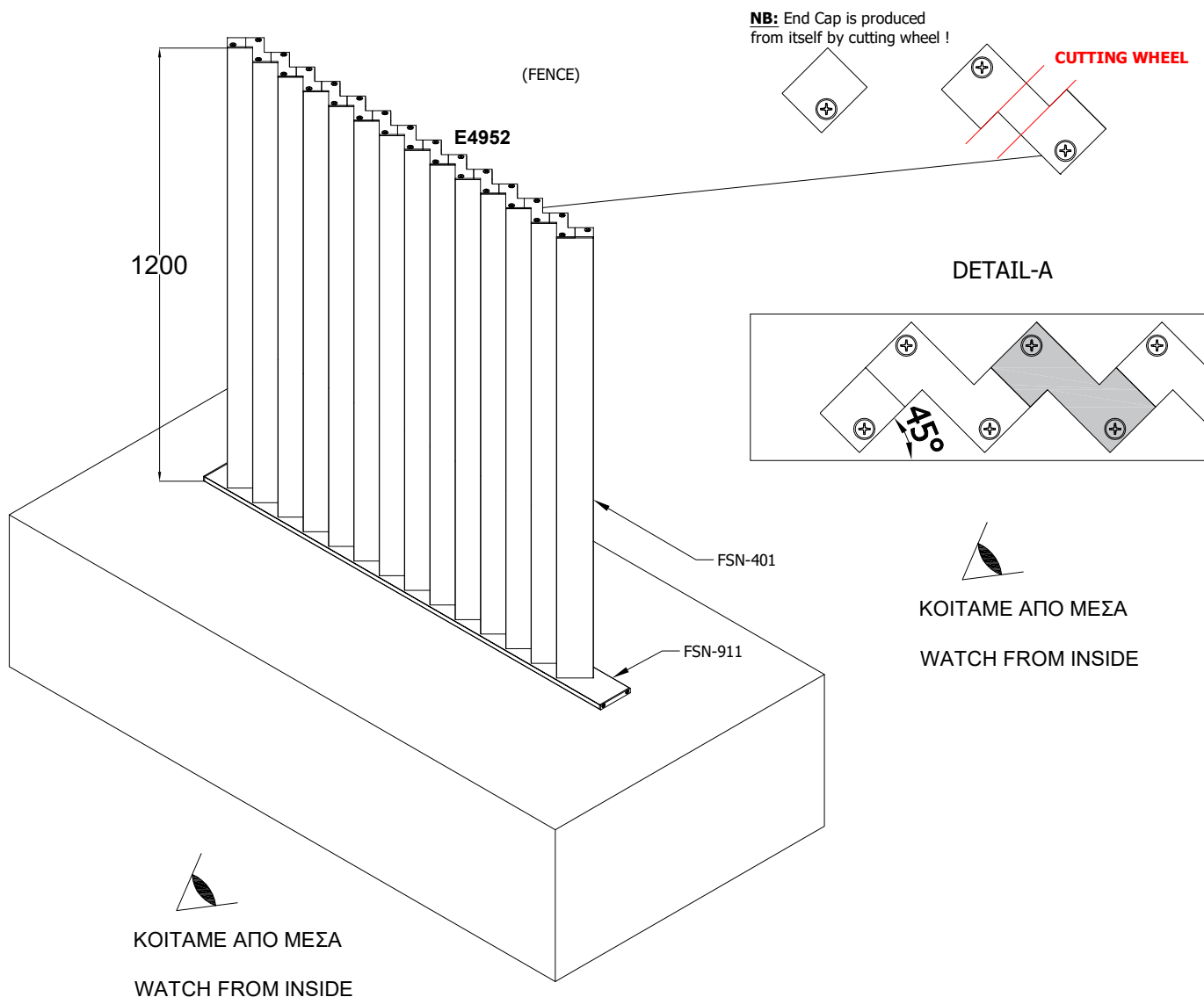

New Fusion Line Type: LEFT ALIGNMENT - (ΑΡΙΣΤΕΡΗ ΔΙΑΤΑΞΗ)
 Top Mount FSN-401 FENCE ANGULAR 45° LINEAR TYPE

Top Cover (Z) - (Ταπα Z)

- Open Gap 20mm (ΦΩΣ 20mm) - **Top Cover (Ταπα) E4952-B & FSN-911.DBU00**
- Open Gap 30mm (ΦΩΣ 30mm) - **Top Cover (Ταπα) E4958-B & FSN-911.DBU10**

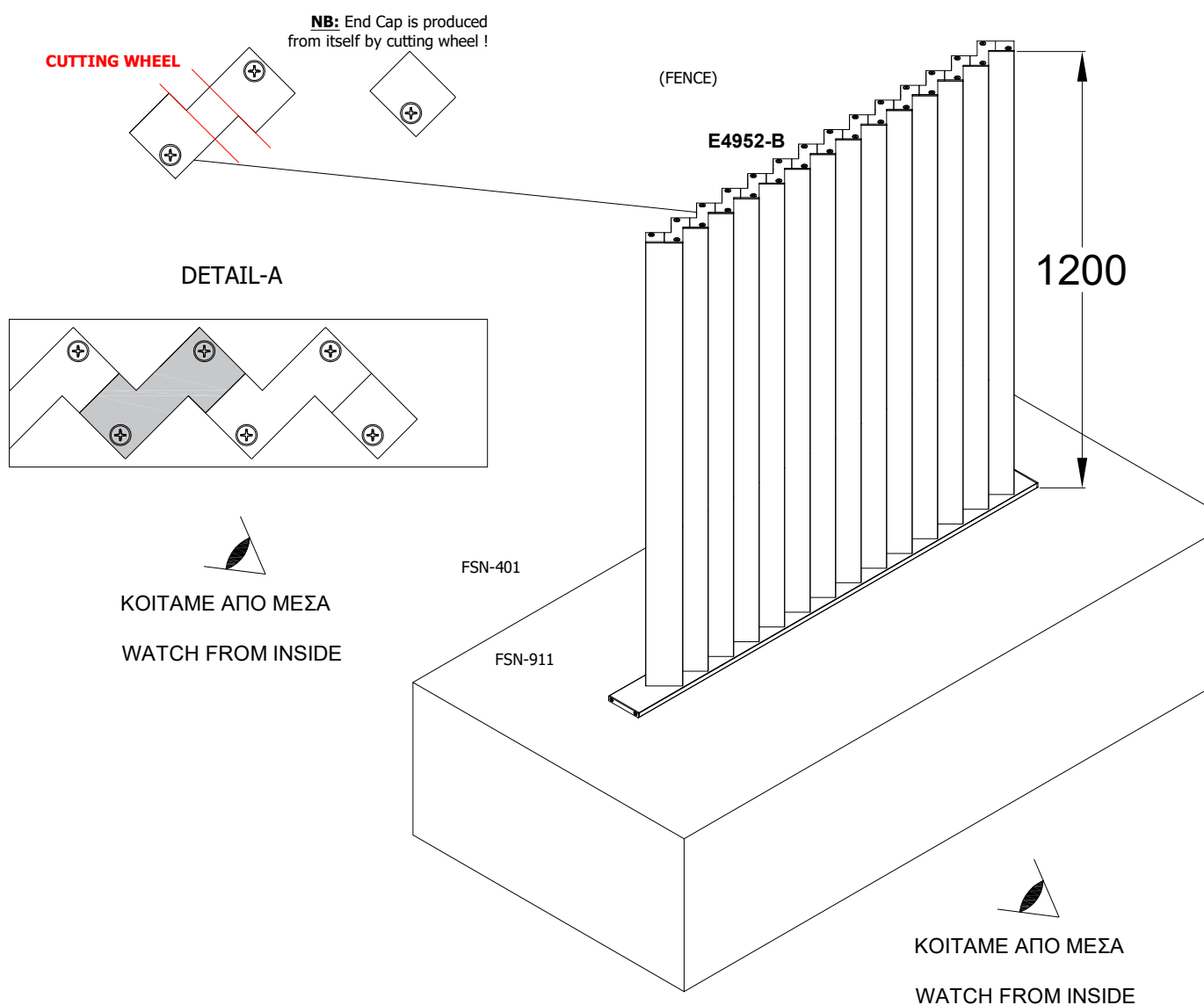

New Fusion Line Type: RIGHT ALIGNMENT - (ΔΕΞΙΑ ΔΙΑΤΑΞΗ)
 Top Mount FSN-401 FENCE ANGULAR 45° LINEAR TYPE

Top Cover Sheet Metal 2mm (Λαμαρίνα 2mm)

- Open Gap 20mm (ΦΩΣ 20mm) - **E4959 & FSN-911.D0U00**
- Open Gap 30mm (ΦΩΣ 30mm) - **E4960 & FSN-911.D0U10**

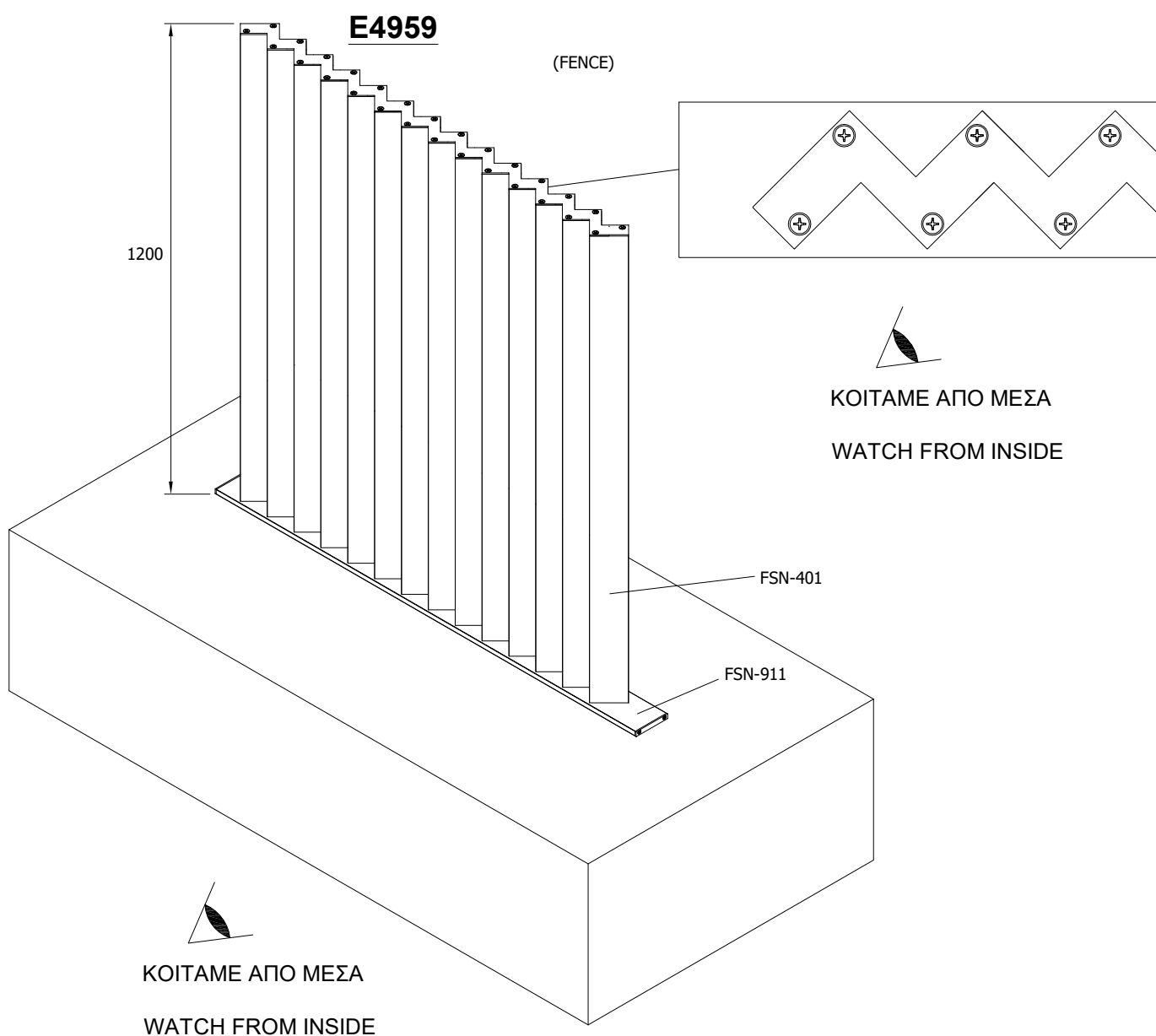

New Fusion Line Type: LEFT ALIGNMENT - (ΑΡΙΣΤΕΡΗ ΔΙΑΤΑΞΗ)
 Top Mount FSN-401 FENCE ANGULAR 45° LINEAR TYPE

Top Cover Sheet Metal 2mm (Λαμαρίνα 2mm)

- Open Gap 20mm (ΦΩΣ 20mm) - **E4959-B & FSN-911.DBU00**
- Open Gap 30mm (ΦΩΣ 30mm) - **E4960-B & FSN-911.DBU10**

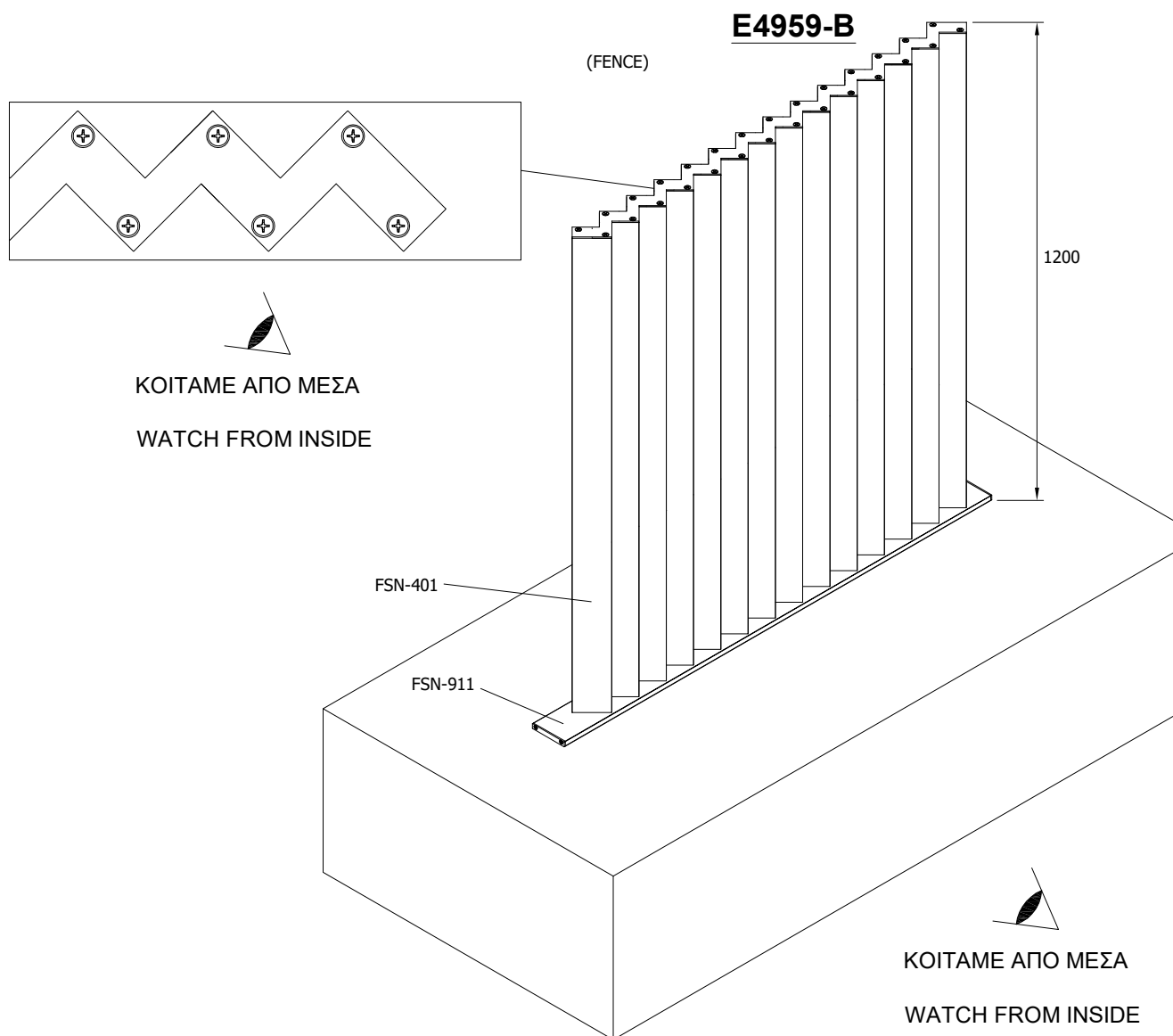

New Fusion Line Type: Top Mount FSN-401 FENCE LINEAR TYPE - SLOPE 45°

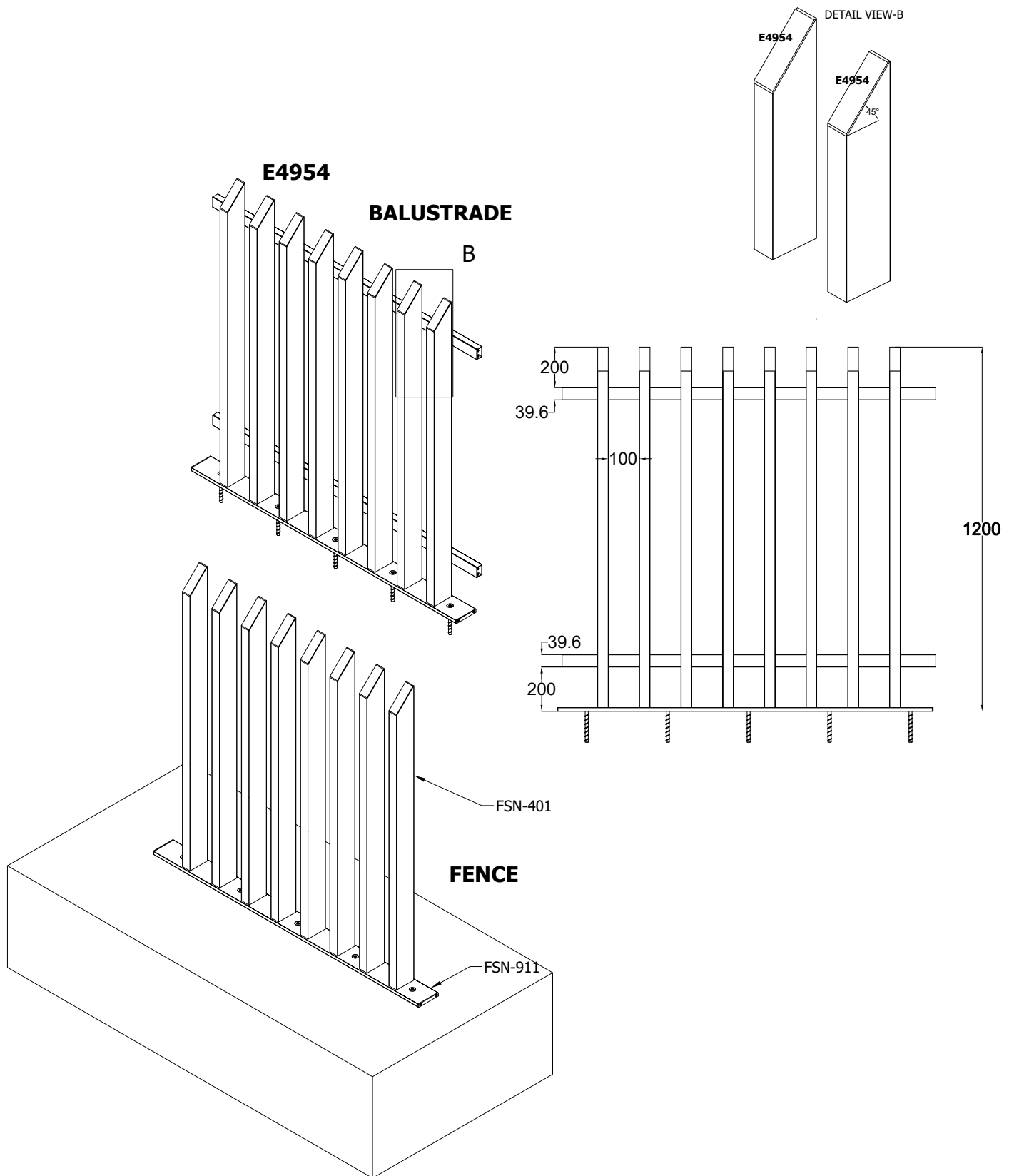

New Fusion Line Type: RIGHT ALIGNMENT - (ΔΕΞΙΑ ΔΙΑΤΑΞΗ)
 Top Mount FSN-401 FENCE LINEAR TYPE - SLOPE CUT 45° - FOS 30mm

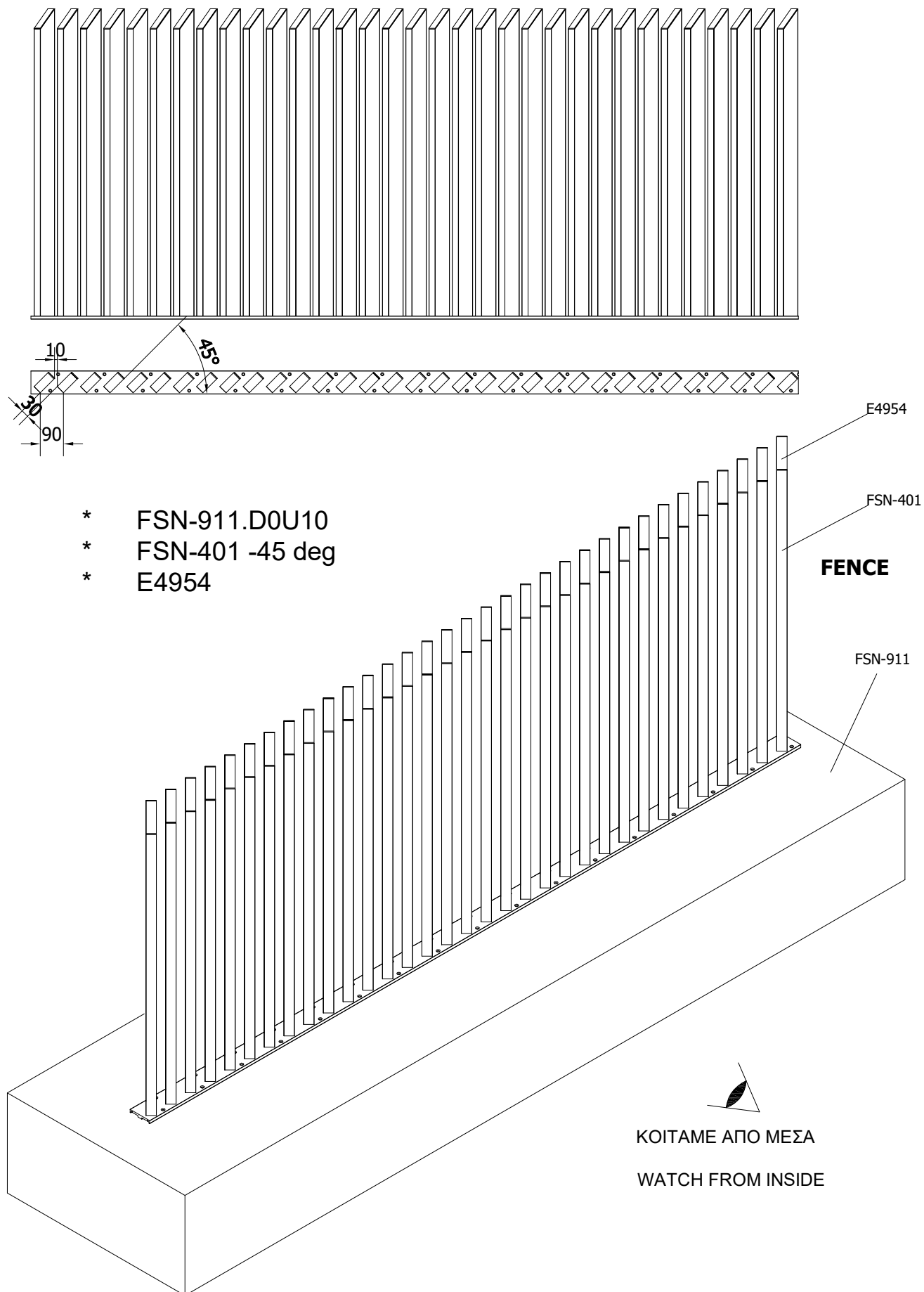

New Fusion Line Type: LEFT ALIGNMENT - (ΑΡΙΣΤΕΡΗ ΔΙΑΤΑΞΗ) Top Mount FSN-401 FENCE LINEAR TYPE - SLOPE CUT 45° - FOS 30mm

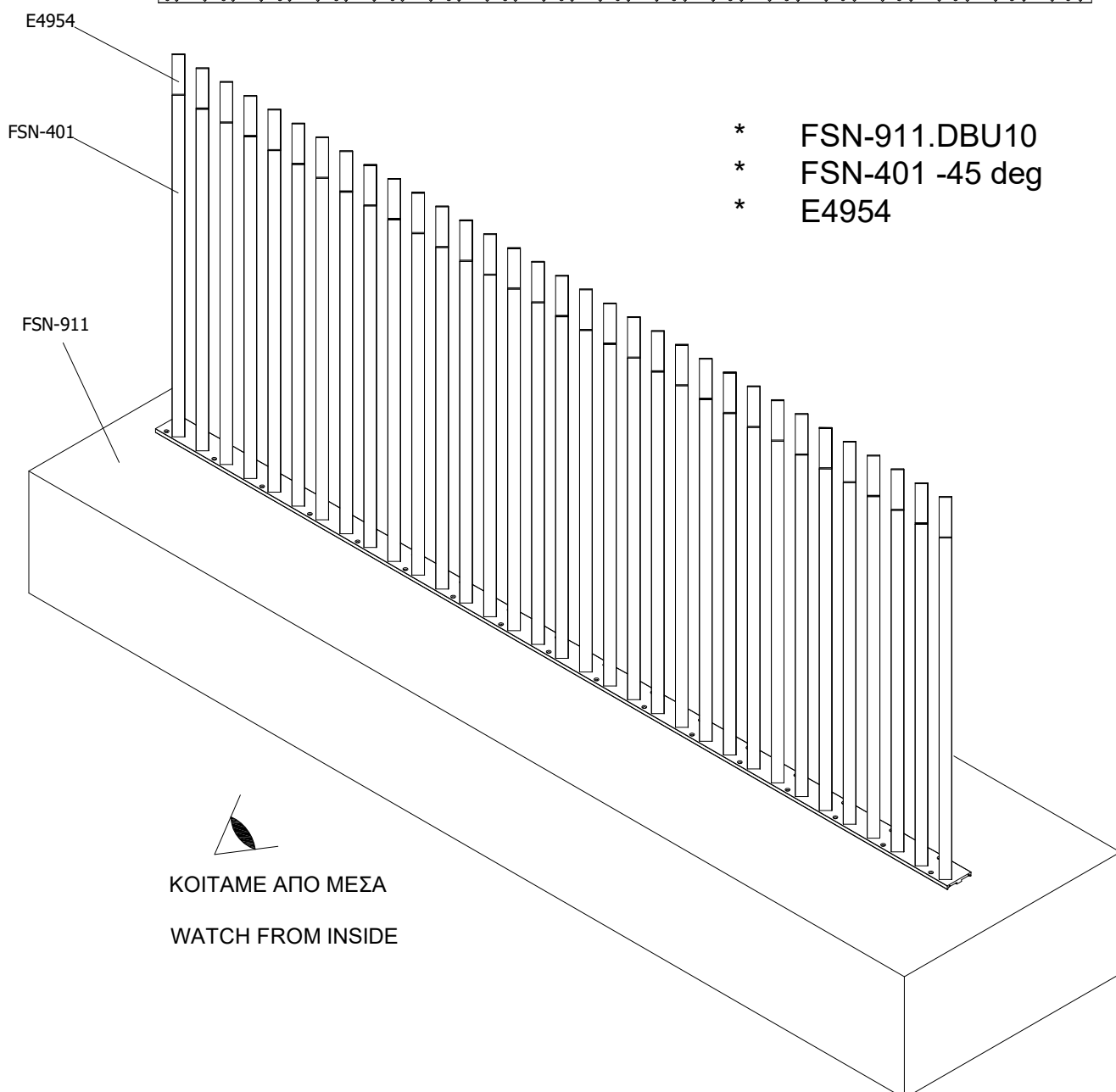
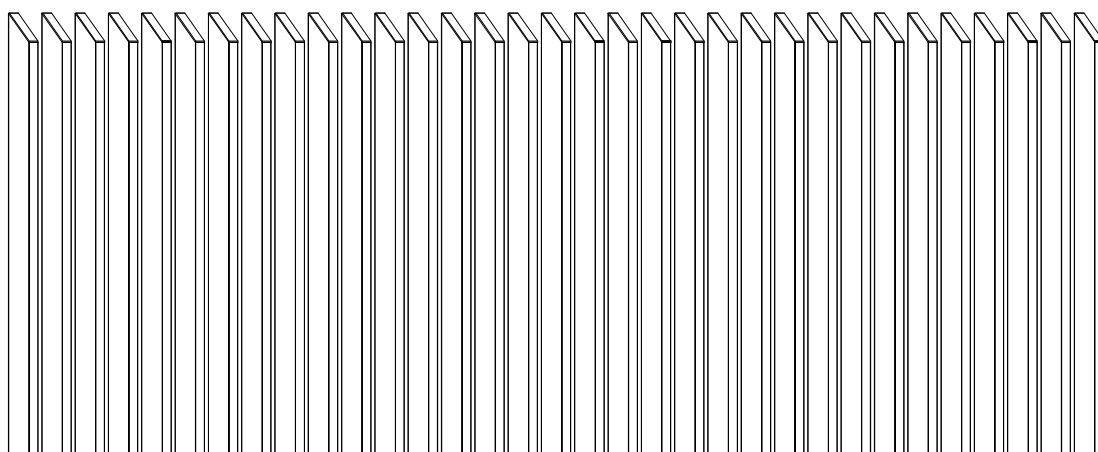

FUSION LINEA-V FENCE FSN-107

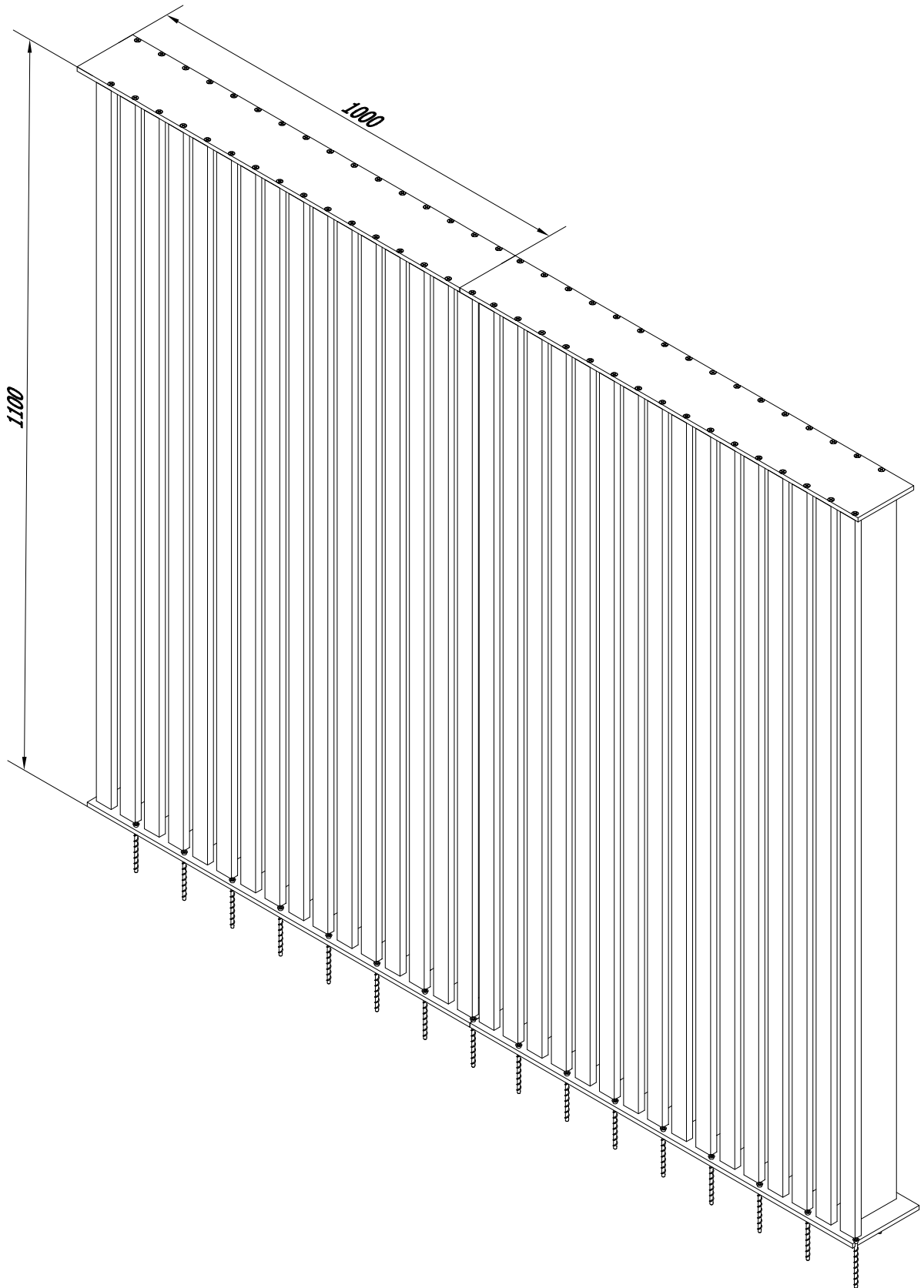

FUSION LINEA-V FENCE FSN-107

*

Flat Bar Code	Περιγραφή / Details
E4645-320	Handrail (39-380) for column FSN-107_Fos 20 mm
E4645-325	Handrail (39-380) for column FSN-107_Fos 25 mm
E4646-320	Handrail (39-182) for column FSN-107_Fos 20 mm
E4646-325	Handrail (39-182) for column FSN-107_Fos 25 mm
E4647-320	Ground base (39-380) for column FSN-107_Fos 20 mm
E4647-325	Ground base (39-380) for column FSN-107_Fos 25 mm

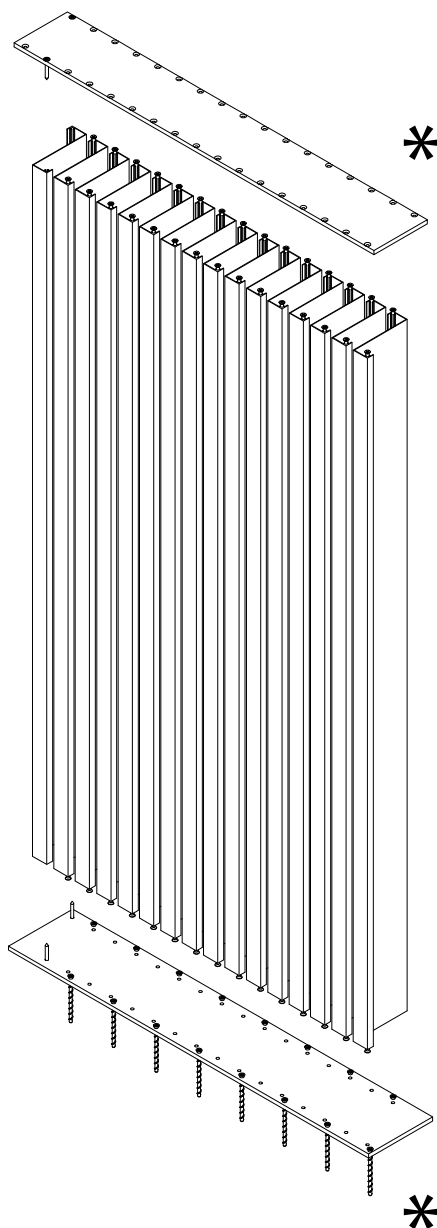

DETAIL VIEW

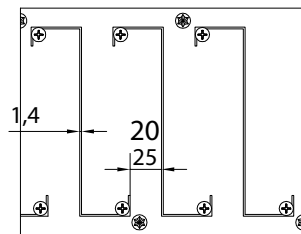

SPACING 25mm or 20mm

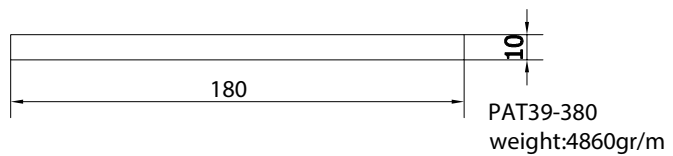
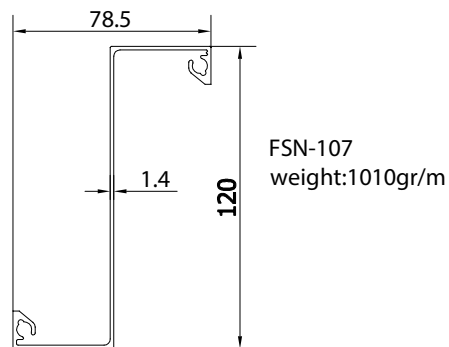
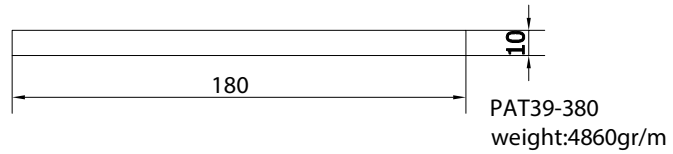

LINEA-V FENCE FSN-107

E4645-325

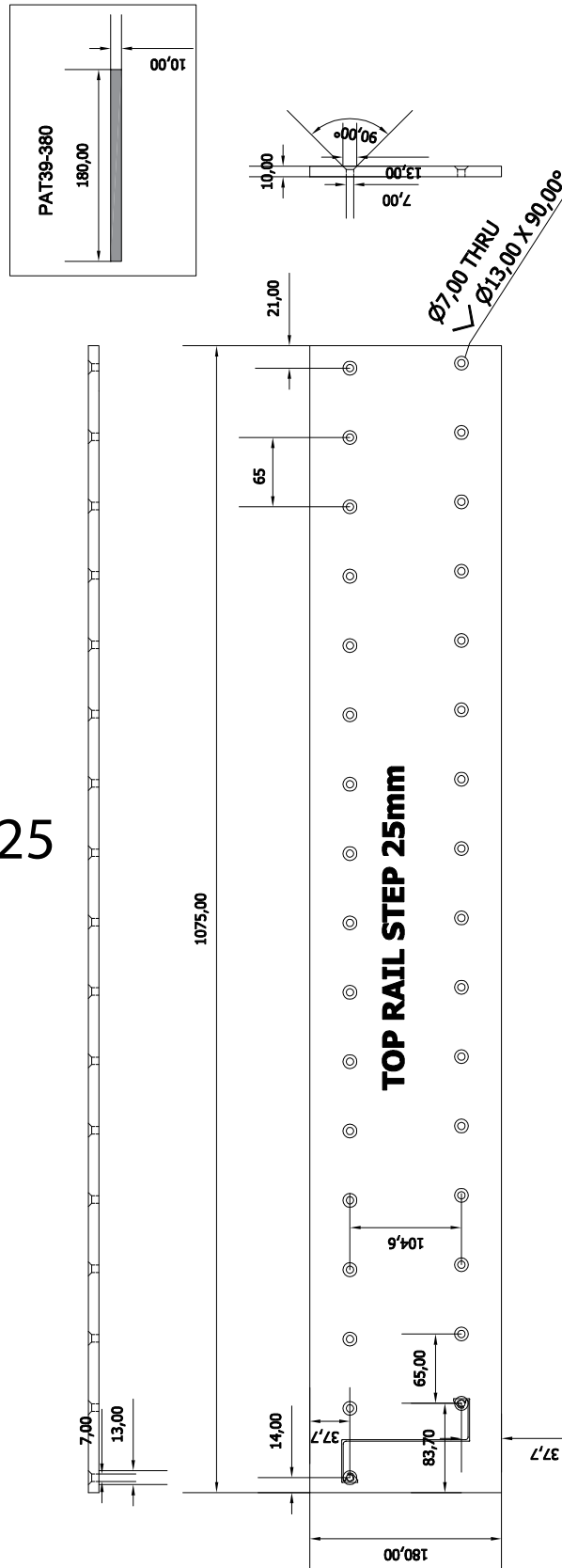

FUSION LINEA-V FENCE FSN-107

E4647-325

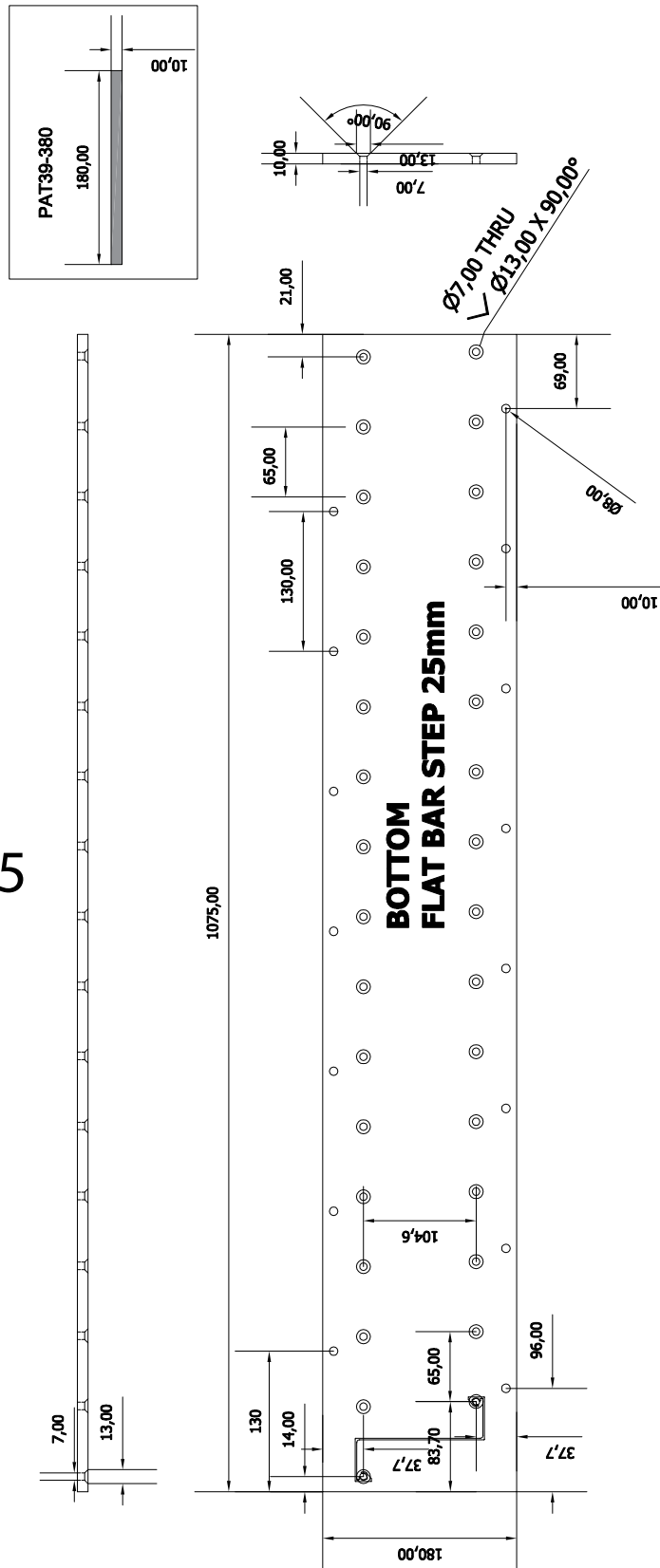

FUSION LINEA-V FENCE FSN-107

E4645-320

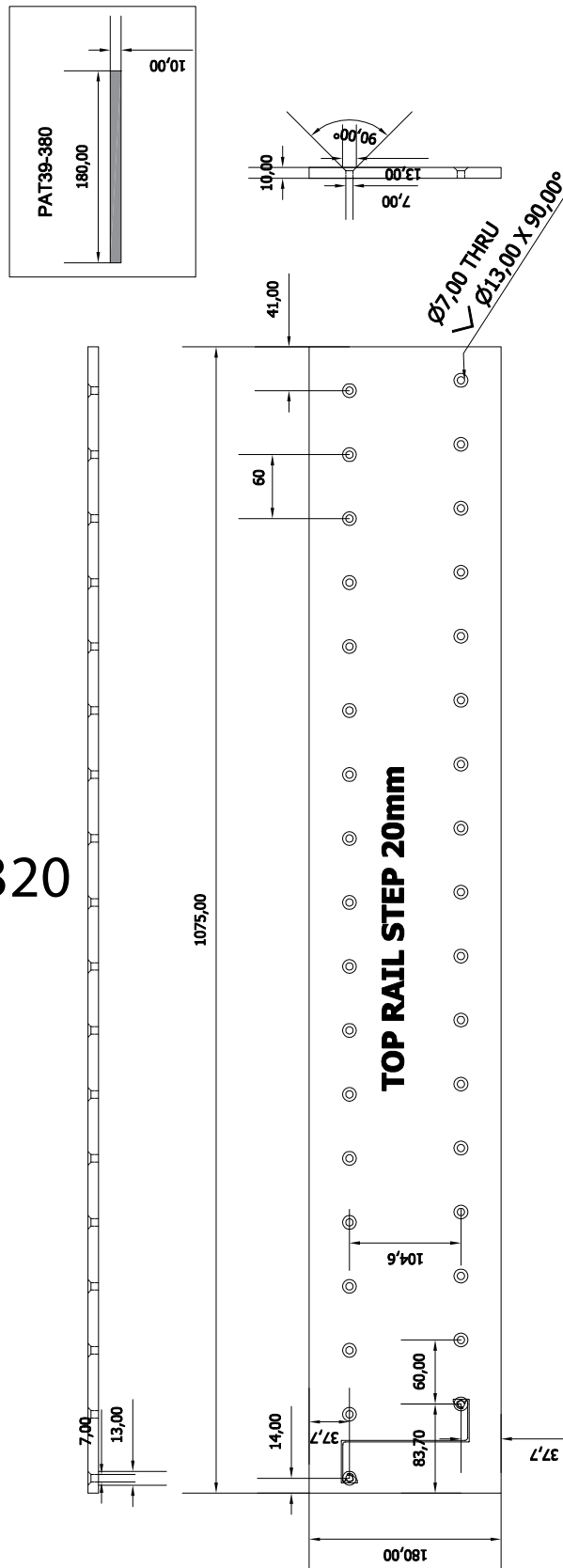

FUSION LINEA-V FENCE FSN-107

E4647-320

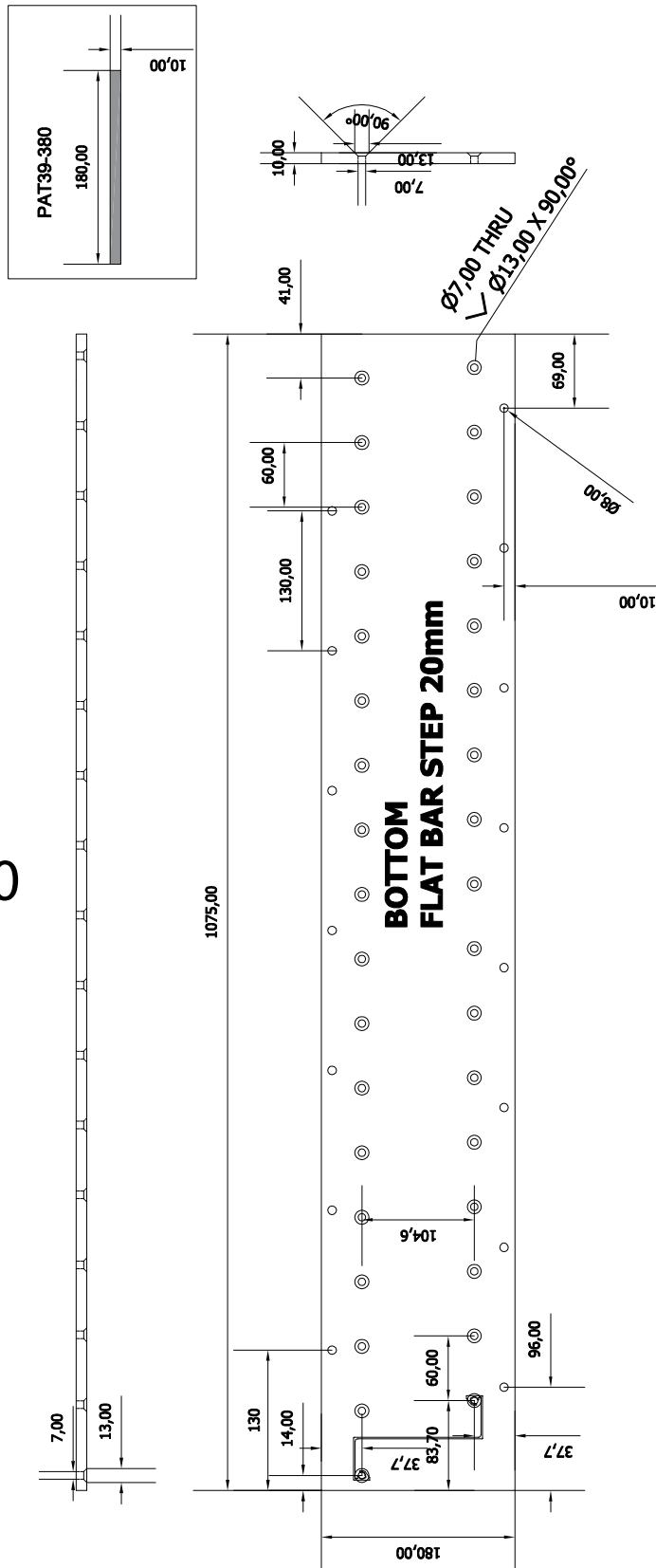

FUSION LINEA-V FENCE FSN-107

E4646-325

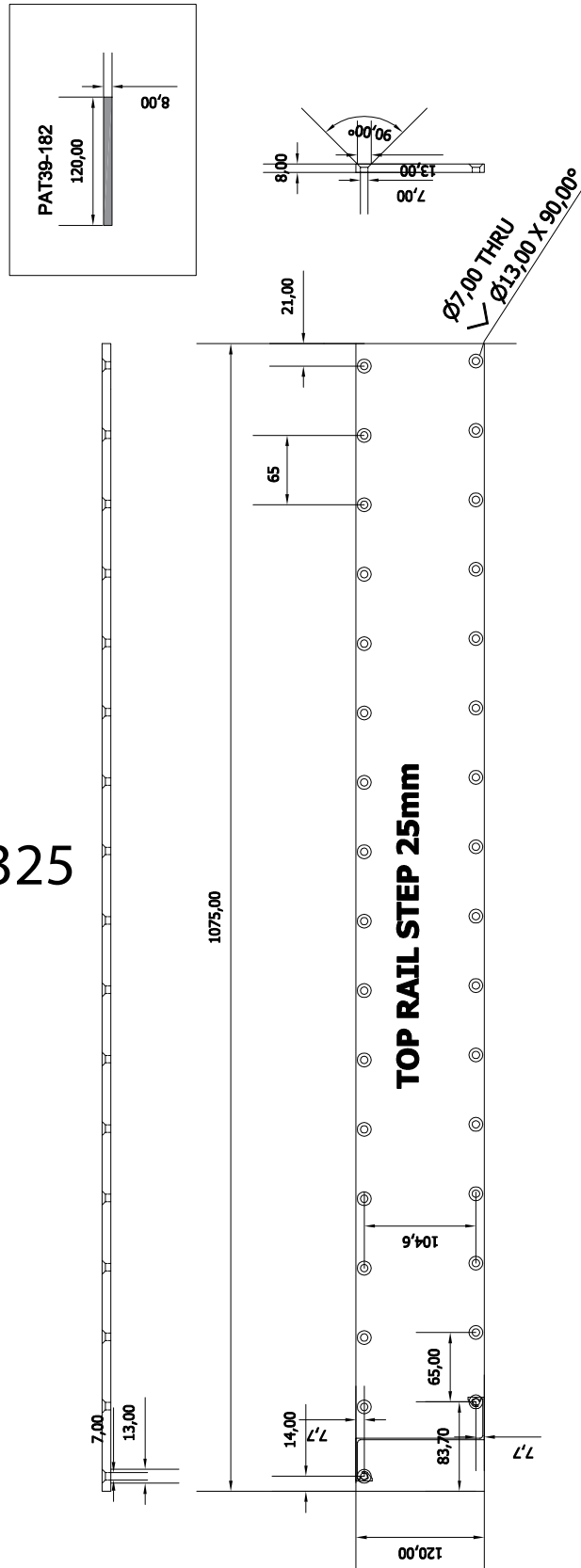

FUSION LINEA-V FENCE FSN-107

E4646-320

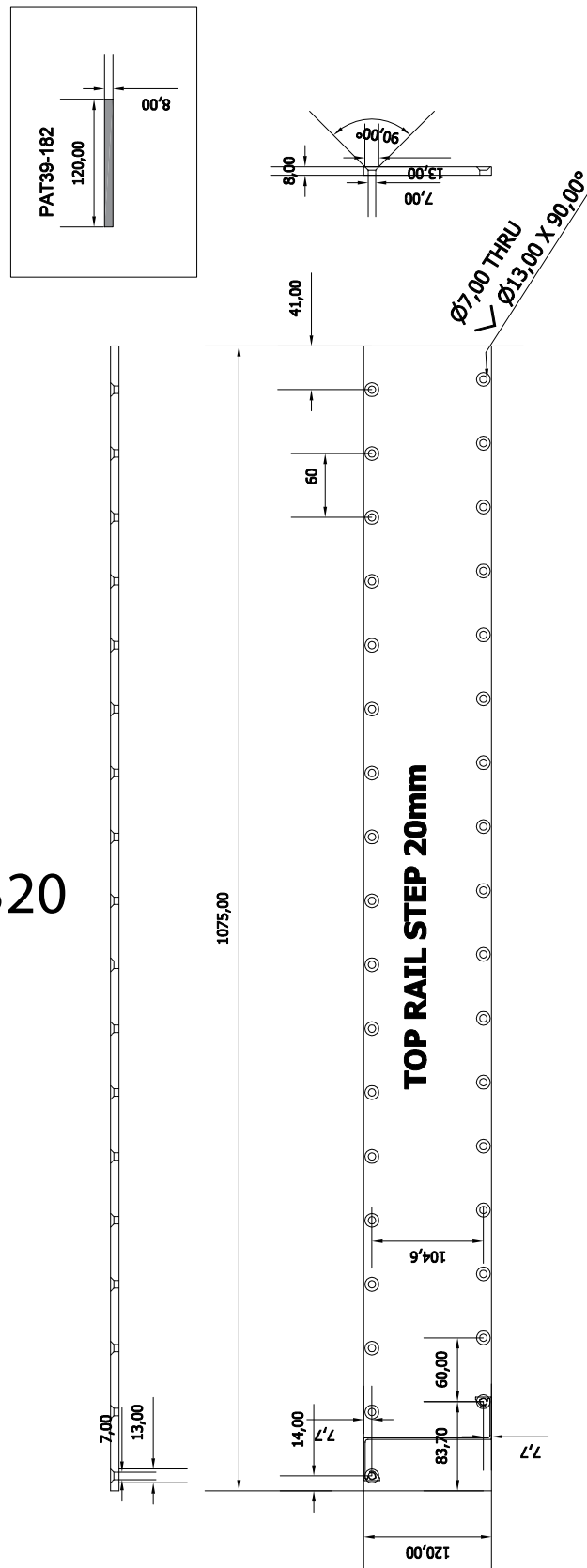

LineaV Fences

Ground fixing guide



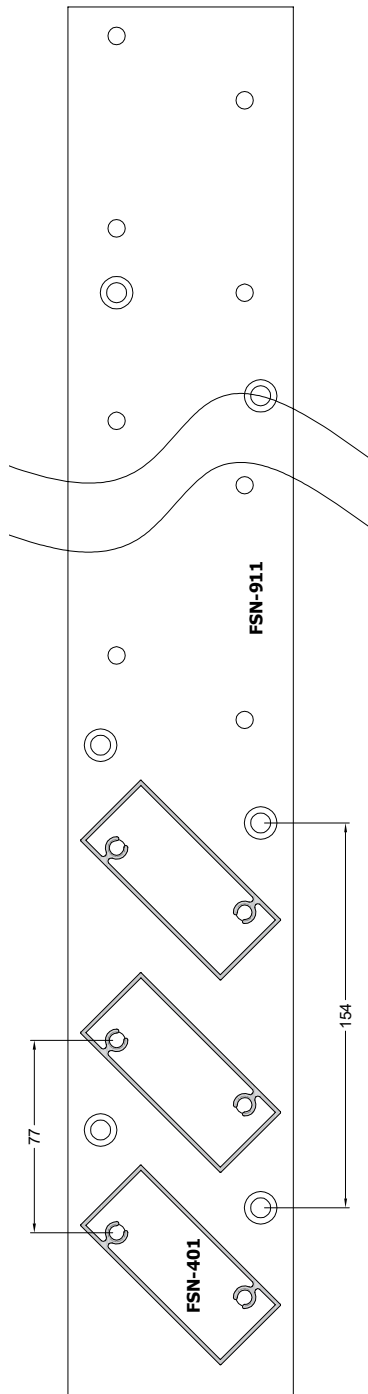

* Στο 3μ προφίλ κάνουμε 78 Τρύπες Φ7
 * Στο 3μ προφίλ κάνουμε 38 Φρεζατες Τρύπες Φ8/Φ13

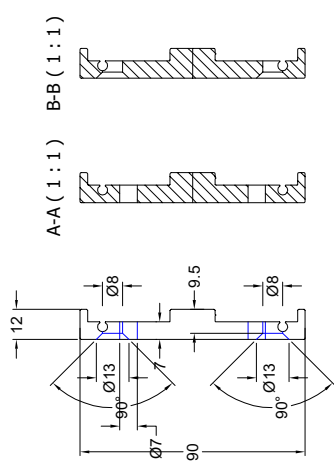
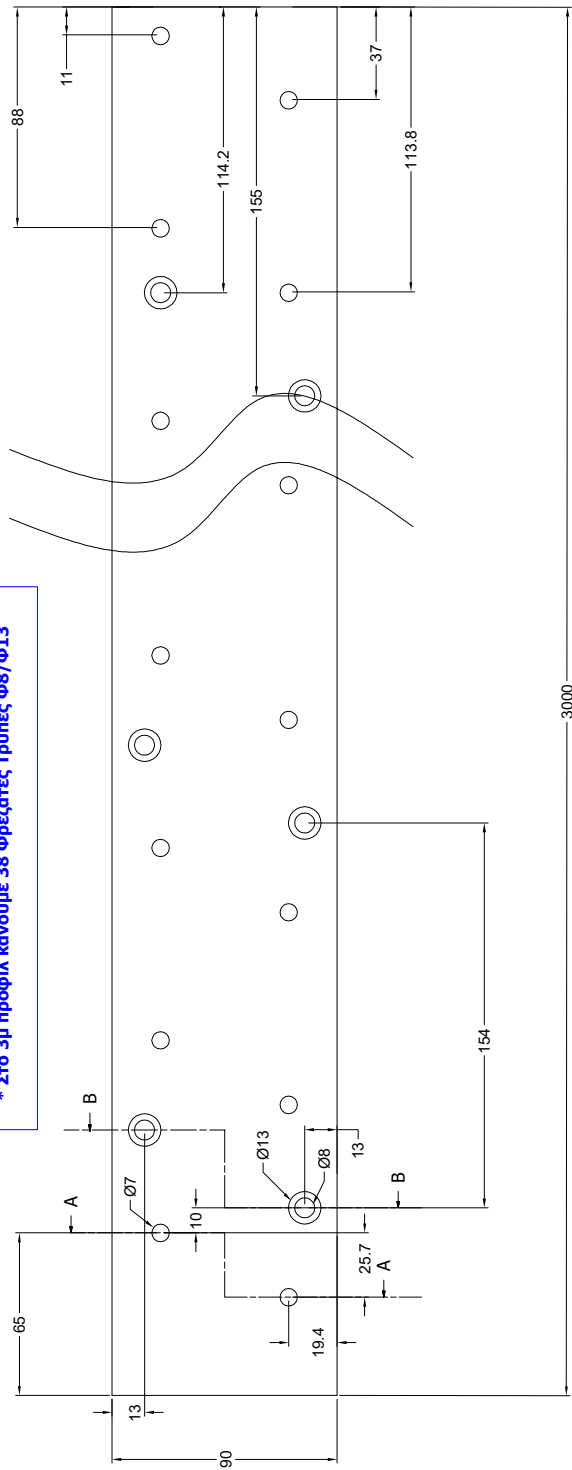
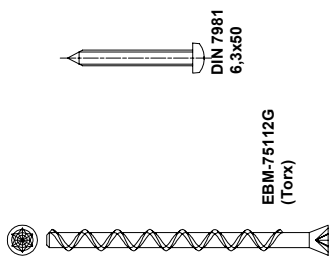

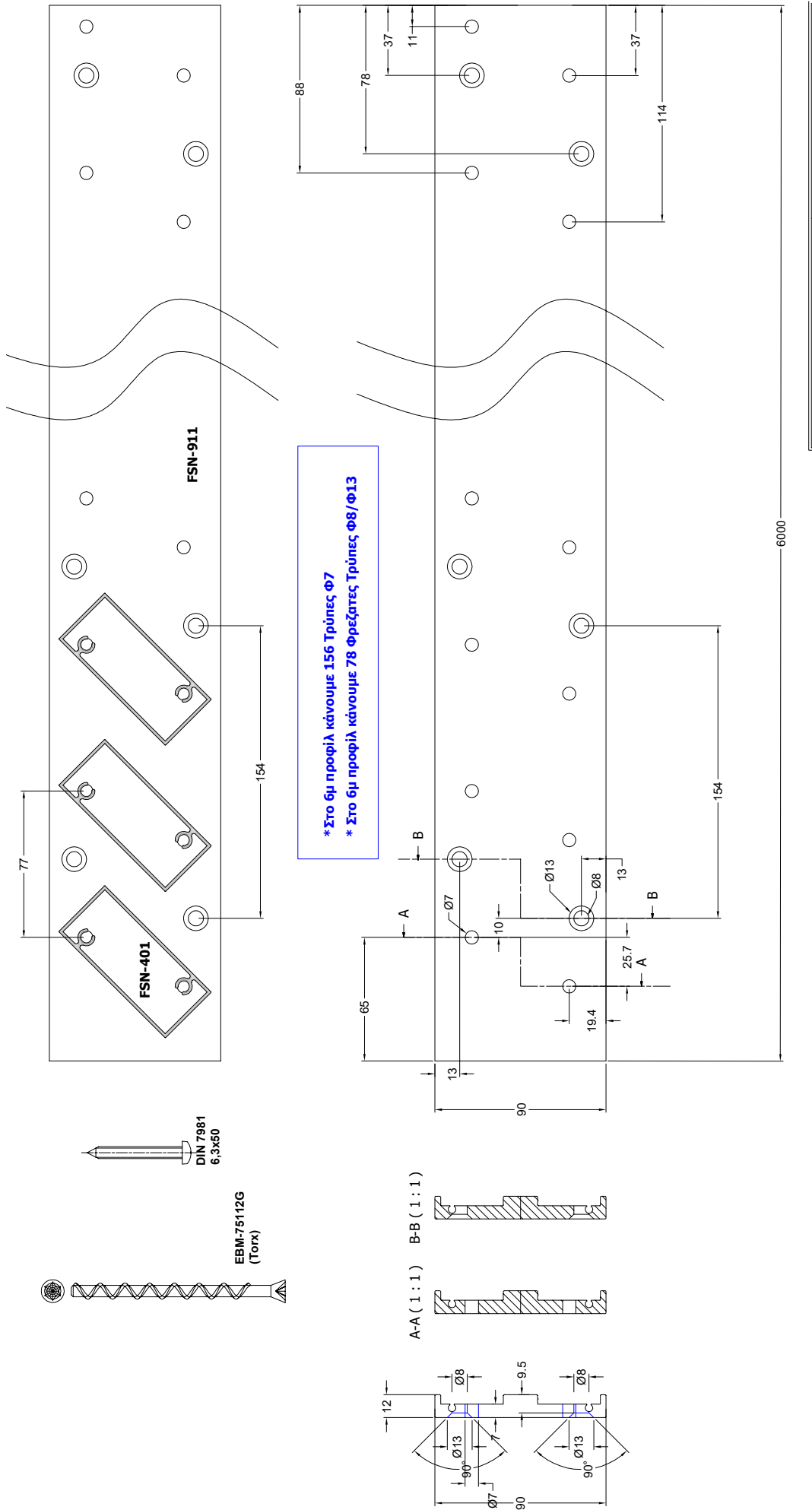

* Στο 6m προφίλ κάνουμε 156 Τρύπες Φ7
 * Στο 6m προφίλ κάνουμε 78 Φρεζατες Τρύπες Φ8/Φ13

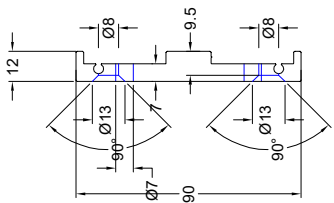
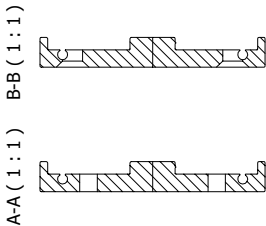
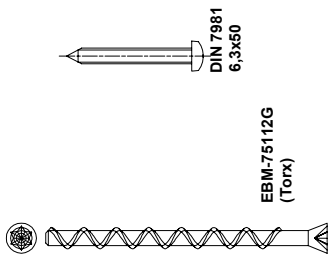

LineaV Profiles, Accessories



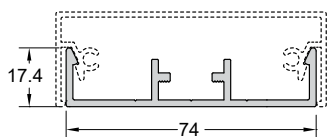

Κωδικός / Code: **CLS-201**

ΒΑΡΟΣ / WEIGHT: 757 gr/m

ΒΑΣΗ ΚΟΥΠΑΣΤΗΣ FSN-221/222

BASE FOR HANDRAIL FSN-221/222

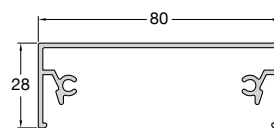

Κωδικός / Code: **FSN-221**

ΒΑΡΟΣ / WEIGHT: 754 gr/m

ΚΑΠΑΚΙ ΚΟΥΠΑΣΤΗΣ 80x28

COVER FOR HANDRAIL 80x28

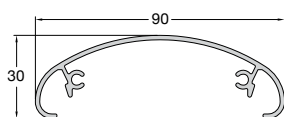

Κωδικός / Code: **FSN-222**

ΒΑΡΟΣ / WEIGHT: 736 gr/m

ΚΑΠΑΚΙ ΚΟΥΠΑΣΤΗΣ ΟΒΑΛ 90x30

COVER FOR HANDRAIL OVAL 90x30

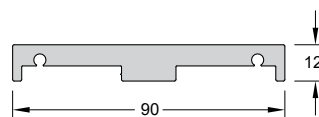

Κωδικός / Code: **FSN-911**

ΒΑΡΟΣ / WEIGHT: 1955 gr/m

ΜΗΚΟΣ / LENGTH: 6m

ΚΑΠΑΚΙ ΚΟΥΠΑΣΤΗΣ ΟΒΑΛ 90x30

COVER FOR HANDRAIL OVAL 90x30

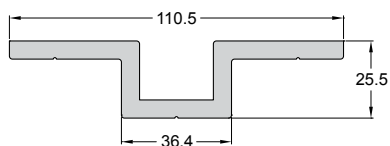

Κωδικός / Code: **P5302-902**

ΒΑΡΟΣ / WEIGHT: 2416 gr/m

ΜΗΚΟΣ / LENGTH: 6m

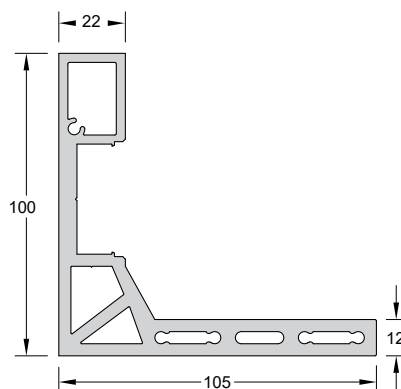

Κωδικός / Code: **FSN-912**

ΒΑΡΟΣ / WEIGHT: 4609 gr/m

ΜΗΚΟΣ / LENGTH: 6m

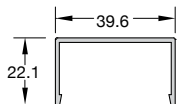

Κωδικός / Code: **CLS-3K2**

ΒΑΡΟΣ / WEIGHT: 324 gr/m

ΜΗΚΟΣ / LENGTH: 6m

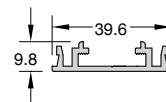

Κωδικός / Code: **CLS-302**

ΒΑΡΟΣ / WEIGHT: 359 gr/m

ΜΗΚΟΣ / LENGTH: 6m

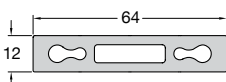

Κωδικός / Code: **FSN-100**

ΒΑΡΟΣ / WEIGHT: 1442 gr/m

ΚΟΛΩΝΑ 12x64 C

OLUMN 12x64

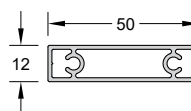

Κωδικός / Code: **FSN-106**

ΒΑΡΟΣ / WEIGHT: 540 gr/m

ΜΗΚΟΣ / LENGTH: 6m

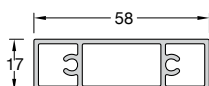

Κωδικός / Code: **FSN-302**

ΒΑΡΟΣ / WEIGHT: 781 gr/m

ΚΑΡΕ 58x17

SQUARE 58x17

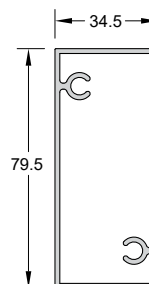

Κωδικός / Code: **FSN-401**

ΒΑΡΟΣ / WEIGHT: 1142 gr/m

ΜΗΚΟΣ / LENGTH: 6m

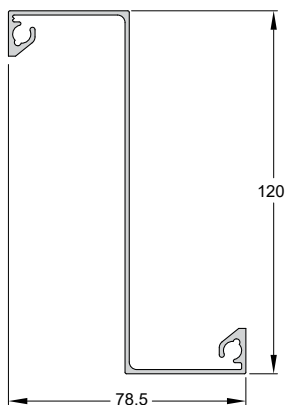

Κωδικός / Code: **FSN-107**

ΒΑΡΟΣ / WEIGHT: 1010 gr/m

ΜΗΚΟΣ / LENGTH: 6m

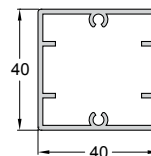

Κωδικός / Code: **F50-106**

ΒΑΡΟΣ / WEIGHT: 794 gr/m

ΜΗΚΟΣ / LENGTH: 6m

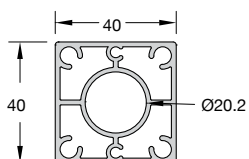

Κωδικός / Code: **CLS-102**

ΒΑΡΟΣ / WEIGHT: 1245 gr/m

ΜΗΚΟΣ / LENGTH: 6m

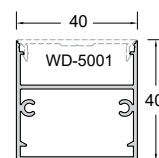

Κωδικός / Code: **WD-4040**

ΒΑΡΟΣ / WEIGHT: 619 gr/m

ΜΗΚΟΣ / LENGTH: 6m



Κωδικός / Code: **4289**

ΓΩΝΙΑΚΟΣ ΣΥΝΔΕΣΜΟΣ 90° ΓΙΑ ΚΟΥΠΑΣΤΗ CLS-201
CORNER CONNECTOR 90° FOR HANDRAIL CLS-201



Κωδικός / Code: **4275**

ΣΥΝΔΕΣΜΟΣ ΕΣΩΤΕΡΙΚΟΥ ΟΔΗΓΟΥ CLS-302 ΕΥΘΕΙΑ
CONNECTOR FOR GUIDE CLS-302



Κωδικός / Code: **4270**

ΣΥΝΔΕΣΜΟΣ CLS-201/301/302/305
CONNECTOR FOR CLS-201/301/302/305



Κωδικός / Code: **4921**

ΤΑΠΑ ΚΟΥΠΑΣΤΗΣ FSN-222
END CAP FOR HANDRAIL FSN-222



Κωδικός / Code: **4922**

ΤΑΠΑ ΚΟΥΠΑΣΤΗΣ FSN-221
END CAP FOR HANDRAIL FSN-221



Κωδικός / Code: **E4949**

ΠΛΑΪΝΗ ΤΑΠΑ ΓΙΑ ΤΟ FSN-911
SIDE COVER FOR FSN-911



Κωδικός / Code: **A334-006**

ΤΑΠΑ ΓΙΑ ΤΟ WD-4040
COVER FOR WD-4040



Κωδικός / Code: **E4950**

ΠΛΑΪΝΗ ΤΑΠΑ ΓΙΑ ΤΟ FSN-912 (PAA)
SIDE COVER FOR FSN-912 (PAA)



Κωδικός / Code: **E4954**

ΛΟΞΗ ΤΑΠΑ 45° ΓΙΑ ΤΟ FSN-401
SLOPE COVER 45° FOR FSN-401



Κωδικός / Code: **E4952**

ΓΩΝΙΑΚΗΣ ΔΙΑΤΑΞΗΣ ΤΑΠΑ ΓΙΑ ΤΟ FSN-401 / ΦΩΣ 20 mm /
ΔΕΞΙΟΣ ΠΡΟΣΑΝΑΤΟΛΙΣΜΟΣ
ANGULAR COVERS FOR FSN-401 / SUN LIGHT 20 mm /
RIGHT ALIGNMENT



Κωδικός / Code: **E4953**

ΕΥΘΥΓΡΑΜΜΗΣ ΔΙΑΤΑΞΗΣ ΤΑΠΑ ΓΙΑ ΤΟ FSN-401
LINEAR COVER FOR FSN-401



Κωδικός / Code: **E4958**

ΓΩΝΙΑΚΗΣ ΔΙΑΤΑΞΗΣ ΤΑΠΑ ΓΙΑ ΤΟ FSN-401 /
ΦΩΣ 30 mm /
ΔΕΞΙΟΣ ΠΡΟΣΑΝΑΤΟΛΙΣΜΟΣ
ANGULAR COVERS FOR FSN-401 / SUN LIGHT 30 mm /
RIGHT ALIGNMENT



Κωδικός / Code: **E4952-B**

ΓΩΝΙΑΚΗΣ ΔΙΑΤΑΞΗΣ ΤΑΠΑ ΓΙΑ ΤΟ FSN-401 /
ΦΩΣ 20 mm /
ΑΡΙΣΤΕΡΟΣ ΠΡΟΣΑΝΑΤΟΛΙΣΜΟΣ
ANGULAR COVERS FOR FSN-401 / SUN LIGHT 20 mm /
LEFT ALIGNMENT



Κωδικός / Code: **E4958-B**

ΓΩΝΙΑΚΗΣ ΔΙΑΤΑΞΗΣ ΤΑΠΑ ΓΙΑ ΤΟ FSN-401 /
ΦΩΣ 30 mm /
ΑΡΙΣΤΕΡΟΣ ΠΡΟΣΑΝΑΤΟΛΙΣΜΟΣ
ANGULAR COVERS FOR FSN-401 / SUN LIGHT 30 mm /
LEFT ALIGNMENT

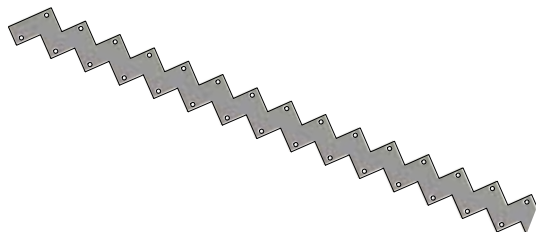

Κωδικός / Code: **E4959**

ΤΕΛΕΙΩΜΑ ΛΑΜΑΡΙΝΑ ΓΩΝΙΑΣ 45° ΓΙΑ ΤΟ FSN-401 /
ΦΩΣ 20 mm / ΔΕΞΙΟΣ ΠΡΟΣΑΝΑΤΟΛΙΣΜΟΣ
SHEET METAL ANGLE 45° COVER FOR FSN-401 /
SUN LIGHT 20 mm / RIGHT ALIGNMENT

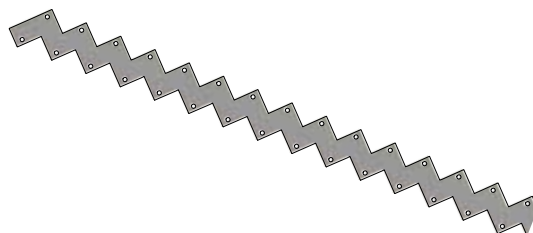

Κωδικός / Code: **E4959-B**

ΤΕΛΕΙΩΜΑ ΛΑΜΑΡΙΝΑ ΓΩΝΙΑΣ 45° ΓΙΑ ΤΟ FSN-401 /
ΦΩΣ 20 mm / ΑΡΙΣΤΕΡΟΣ ΠΡΟΣΑΝΑΤΟΛΙΣΜΟΣ
SHEET METAL ANGLE 45° COVER FOR FSN-401 /
SUN LIGHT 20 mm / LEFT ALIGNMENT

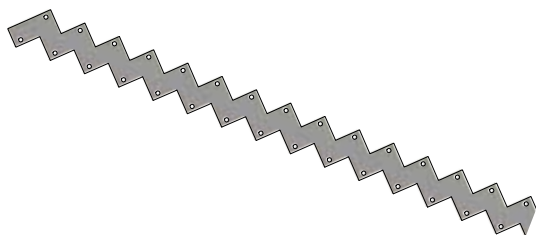

Κωδικός / Code: **E4960**

ΤΕΛΕΙΩΜΑ ΛΑΜΑΡΙΝΑ ΓΩΝΙΑΣ 45° ΓΙΑ ΤΟ FSN-401 /
ΦΩΣ 30 mm / ΔΕΞΙΟΣ ΠΡΟΣΑΝΑΤΟΛΙΣΜΟΣ
SHEET METAL ANGLE 45° COVER FOR FSN-401 /
SUN LIGHT 30 mm / RIGHT ALIGNMENT

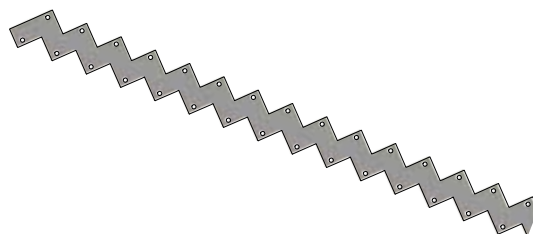

Κωδικός / Code: **E4960-B**

ΤΕΛΕΙΩΜΑ ΛΑΜΑΡΙΝΑ ΓΩΝΙΑΣ 45° ΓΙΑ ΤΟ FSN-401 /
ΦΩΣ 30 mm / ΑΡΙΣΤΕΡΟΣ ΠΡΟΣΑΝΑΤΟΛΙΣΜΟΣ
SHEET METAL ANGLE 45° COVER FOR FSN-401 / SUN LIGHT
30 mm / LEFT ALIGNMENT

Orbit



Orbit 1 Assembly



ΓΩΝΙΑΚΗ ΚΟΛΩΝΑ

CORNER POST

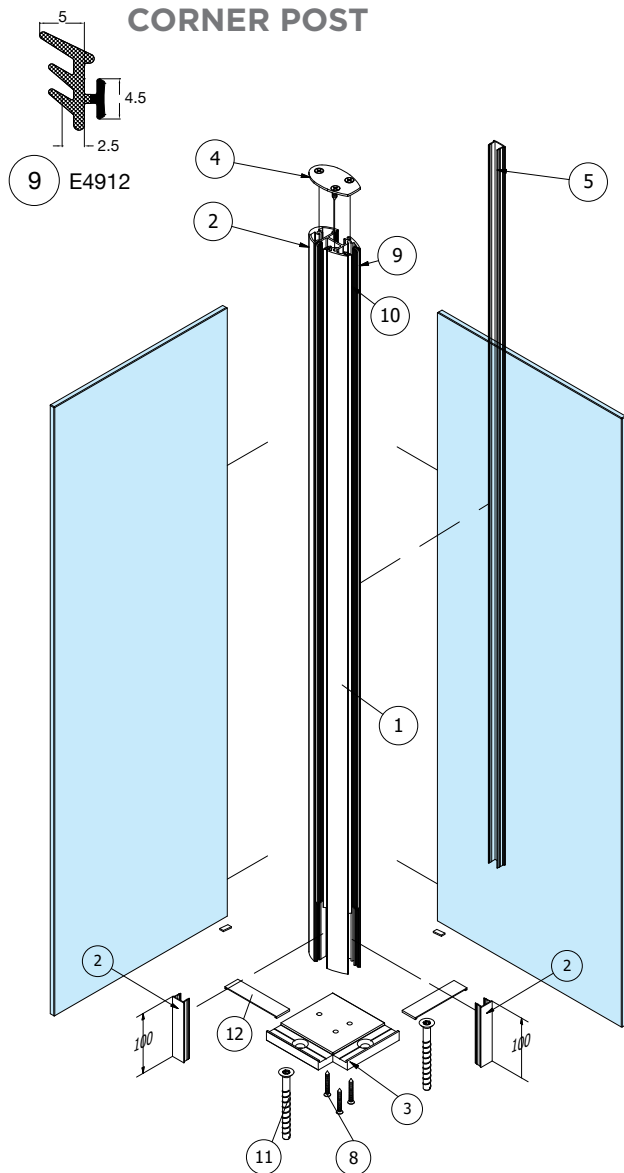

ΚΥΡΙΑ ΚΟΛΩΝΑ

MAIN POST

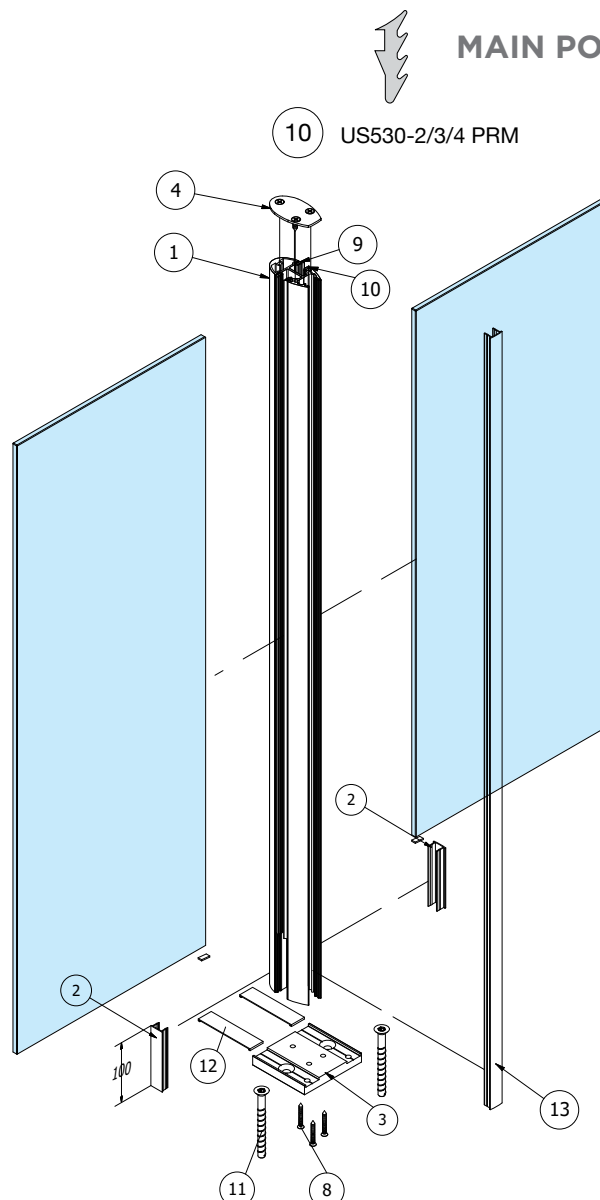

ΛΙΣΤΑ ΥΛΙΚΩΝ / PARTS LIST			
TEM ITEM	ΠΟΣ/ΤΑ QTY	ΚΩΔ. ΕΞΑΡΤΗΜΑΤΟΣ PART NUMBER	DESCRIPTION / ΠΕΡΙΓΡΑΦΗ
1	1	FSN-102	ΚΟΛΩΝΑ ΟΡΒΙΤ1 / ORBIT1 POST
2	2	FSN-122 (100 mm)	ΑΠΟΣΤΑΤΗΣ ΥΑΛΟΠΙΝΑΚΑ GLASS STAND-OFF
5	1	FSN-122	ΠΛΑΙΝΟ ΚΑΠΑΚΙ ΚΟΛΩΝΑΣ POST SIDE CAP
3	1	4716 (Pair)	ΟΡΒΙΤ 1 FOOTPLATE ORBIT 1 ΓΩΝ. ΠΕΛΜΑ
4	1	4924	ΑΝΩ ΤΑΠΑ ΟΡΒΙΤ1 / ORBIT1 TOP COVER
8	3	DIN7982-6.3X50	FOOTPLATE SCREWS ΒΙΔΕΣ ΠΕΛΜΑΤΟΣ
9	2	E4912	ΛΑΣΤΙΧΟ / GASKET
10	2	US530-1/2/3/4 PRM	ΛΑΣΤΙΧΟ ΣΦΗΝΑ / GLAZING GASKET
11	2	EBM-10120G/2	ΜΠΕΤΟΒΙΔΑ / FISCHER CONCRETE SCREW
12	2	4710	FOOTPLATE COVER / ΚΑΠΑΚΙ ΠΕΛΜΑΤΟΣ

ΛΙΣΤΑ ΥΛΙΚΩΝ / PARTS LIST			
TEM ITEM	ΠΟΣ/ΤΑ QTY	ΚΩΔ. ΕΞΑΡΤΗΜΑΤΟΣ PART NUMBER	DESCRIPTION / ΠΕΡΙΓΡΑΦΗ
1	1	FSN-102	ΚΟΛΩΝΑ ΟΡΒΙΤ1 / ORBIT1 POST
2	2	FSN-122 (100 mm)	ΑΠΟΣΤΑΤΗΣ ΥΑΛΟΠΙΝΑΚΑ GLASS STAND-OFF
3	1	4713	ΠΕΛΜΑ ΟΡΒΙΤ1 / ORBIT1 FOOTPLATE
4	1	4924	ΑΝΩ ΤΑΠΑ ΟΡΒΙΤ1 / ORBIT1 TOP COVER
8	3	DIN7982-6.3X50	ΒΙΔΕΣ ΠΕΛΜΑΤΟΣ / FOOTPLATE SCREWS
9	2	E4912	ΛΑΣΤΙΧΟ / GASKET
10	2	US530-1/2/3/4 PRM	ΛΑΣΤΙΧΟ ΣΦΗΝΑ / GLAZING GASKET
11	2	EBM-10120G/2	ΜΠΕΤΟΒΙΔΑ / FISCHER CONCRETE SCREW
12	2	E4710	ΚΑΠΑΚΙ ΠΕΛΜΑΤΟΣ / FOOTPLATE COVER
13	1	FSN-122	ΠΛΑΙΝΟ ΚΑΠΑΚΙ ΚΟΛΩΝΑΣ POST SIDE CAP

MAIN POST

THREE WAY GLASS PANES

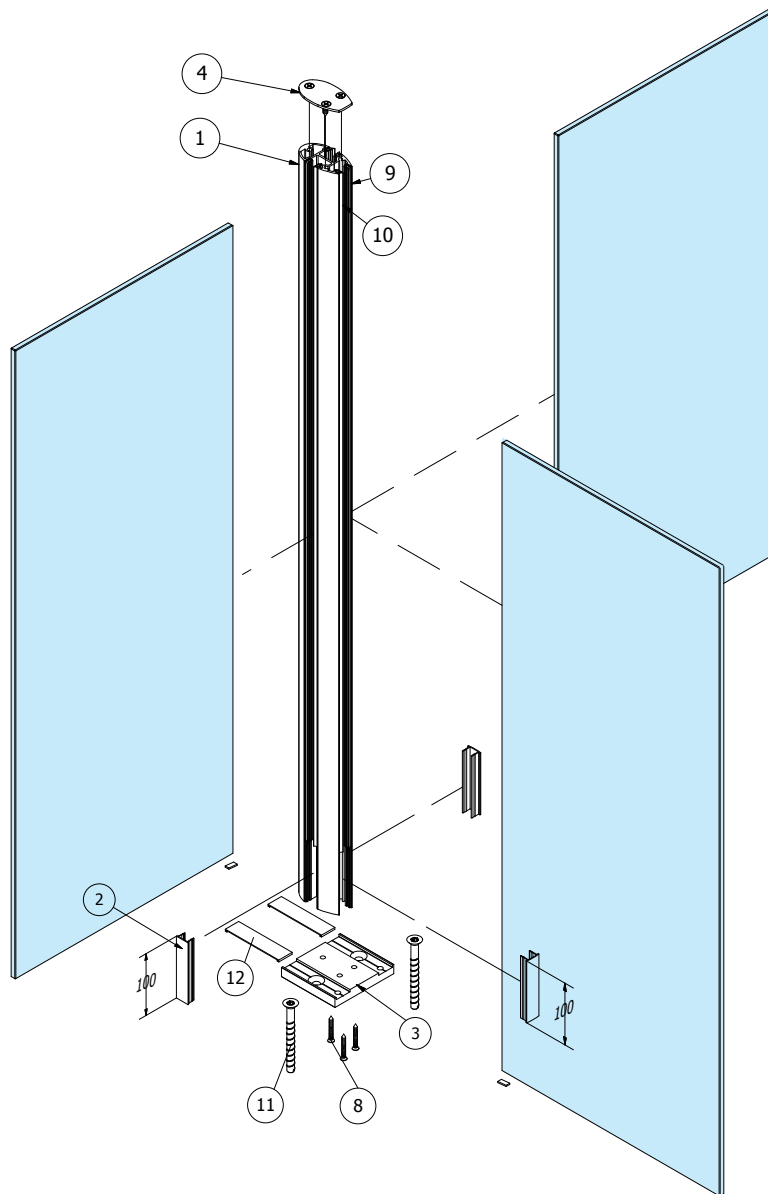

ΛΙΣΤΑ ΥΛΙΚΩΝ / PARTS LIST			
ΤΕΜ ΙΤΕΜ	ΠΟΣ/ΤΑ QTY	ΚΩΔ. ΕΞΑΡΤΗΜΑΤΟΣ PART NUMBER	DESCRIPTION / ΠΕΡΙΓΡΑΦΗ
1	1	FSN-102	ΚΟΛΩΝΑ ORBIT 1 / ORBIT 1 POST
2	2	FSN-122 (100MM)	ΑΠΟΣΤΑΤΗΣ ΥΑΛΟΠΙΝΑΚΑ GLASS STAND-OFF
3	1	4713	ORBIT1 ΠΕΛΜΑ / ORBIT1 FOOTPLATE
4	1	4924	ΑΝΩ ΤΑΠΑ ORBIT1 / ORBIT1 TOP COVER
8	3	DIN7982-6.3x50	ΒΙΔΕΣ ΠΕΛΜΑΤΟΣ / FOOTPLATE SCREWS
9	2	E4912	ΛΑΣΤΙΧΟ / GASKET
10	2	US530-1/2/3/4 PRM	ΛΑΣΤΙΧΟ ΣΦΗΝΑ / GLAZING GASKET
11	2	EBM-10120G/2	ΜΠΕΤΟΒΙΔΑ / FISCHER CONCRETE SCREW
12	2	4710	ΚΑΠΑΚΙ ΠΕΛΜΑΤΟΣ / FOOTPLATE COVER

ONLY POST

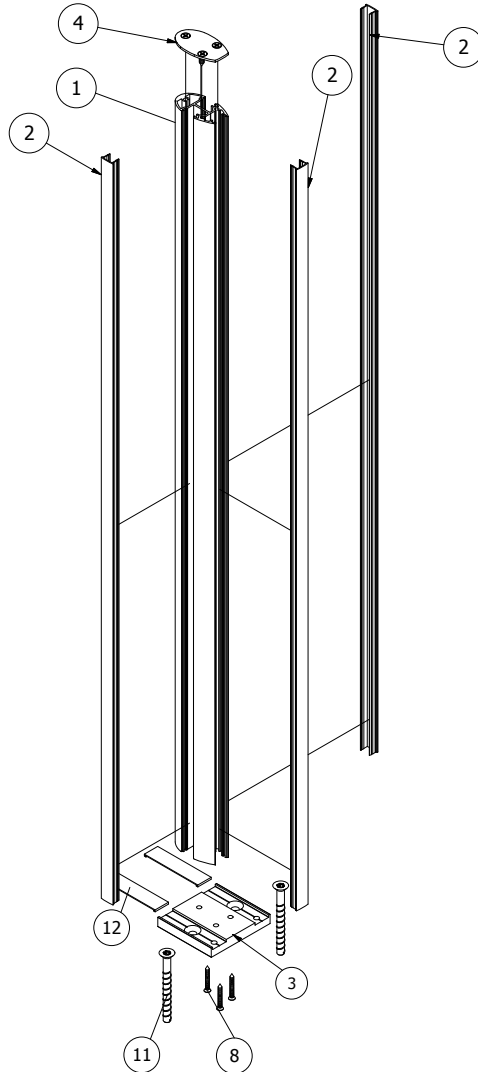

ΛΙΣΤΑ ΥΛΙΚΩΝ / PARTS LIST			
ΤΕΜ ΙΤΕΜ	ΠΟΣ/ΤΑ QTY	ΚΩΔ. ΕΞΑΡΤΗΜΑΤΟΣ PART NUMBER	DESCRIPTION / ΠΕΡΙΓΡΑΦΗ
1	1	F5N-102	ΚΟΛΩΝΑ ORBIT 1 / ORBIT 1 POST
2	3	F5N-122	ΠΛΑΙΝΟ ΚΑΠΑΚΙ ΚΟΛΩΝΑΣ POST SIDE CAP
3	1	4713	ΠΕΛΜΑ ORBIT1 / ORBIT1 FOOTPLATE
4	1	4924	ΑΝΩ ΤΑΠΑ ORBIT 1 / ORBIT 1 TOP COVER
8	3	DIN7982-6.3x50	ΒΙΔΕΣ ΠΕΛΜΑΤΟΣ / FOOTPLATE SCREWS
11	2	EBM-10120G/2	ΜΠΕΤΟΒΙΔΑ / FISCHER CONCRETE SCREW
12	2	4710	ΚΑΠΑΚΙ ΠΕΛΜΑΤΟΣ / FOOTPLATE COVER

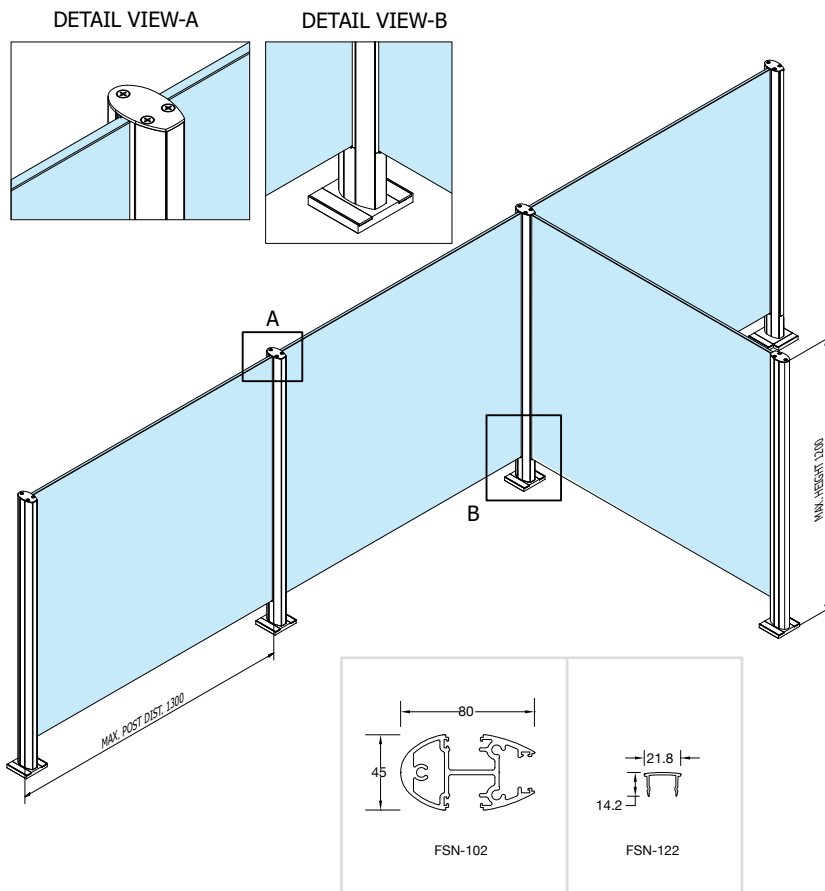

WITH RAILTOP

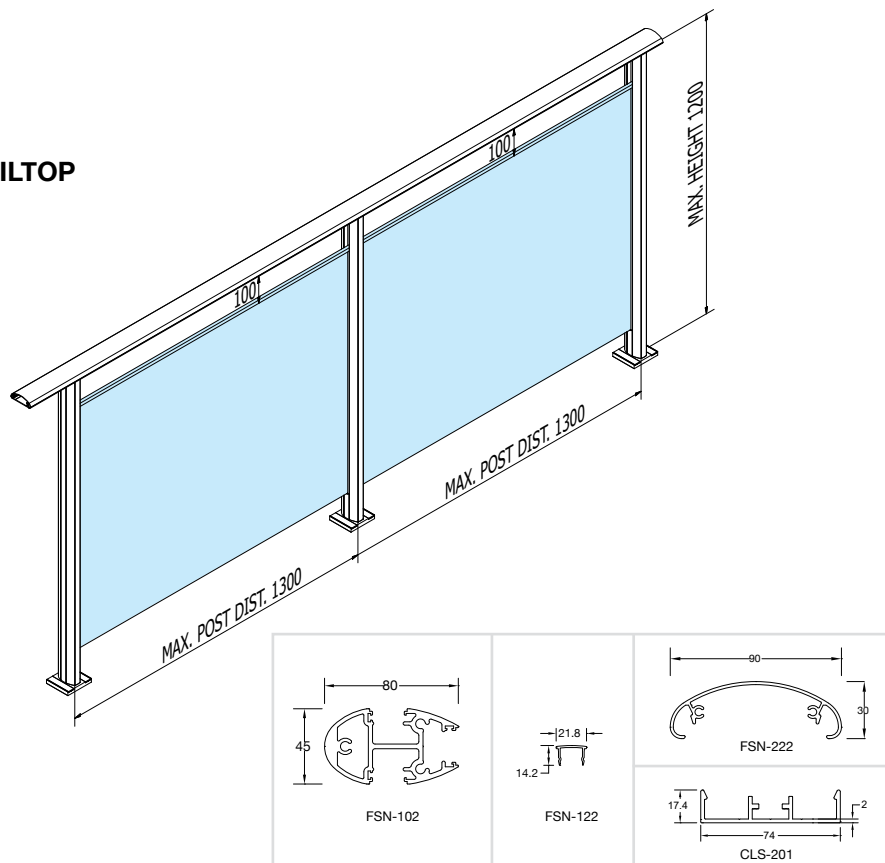

SIDE MOUNT-CORNER ORBIT-01

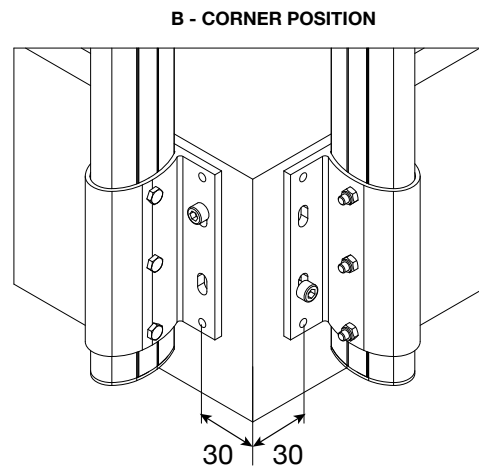
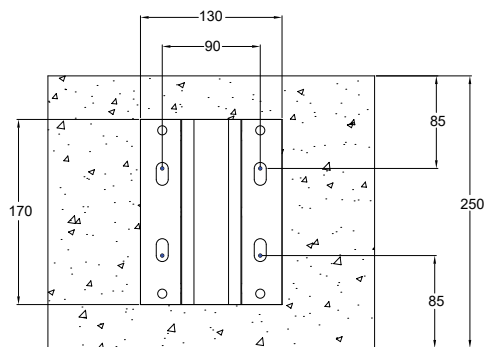
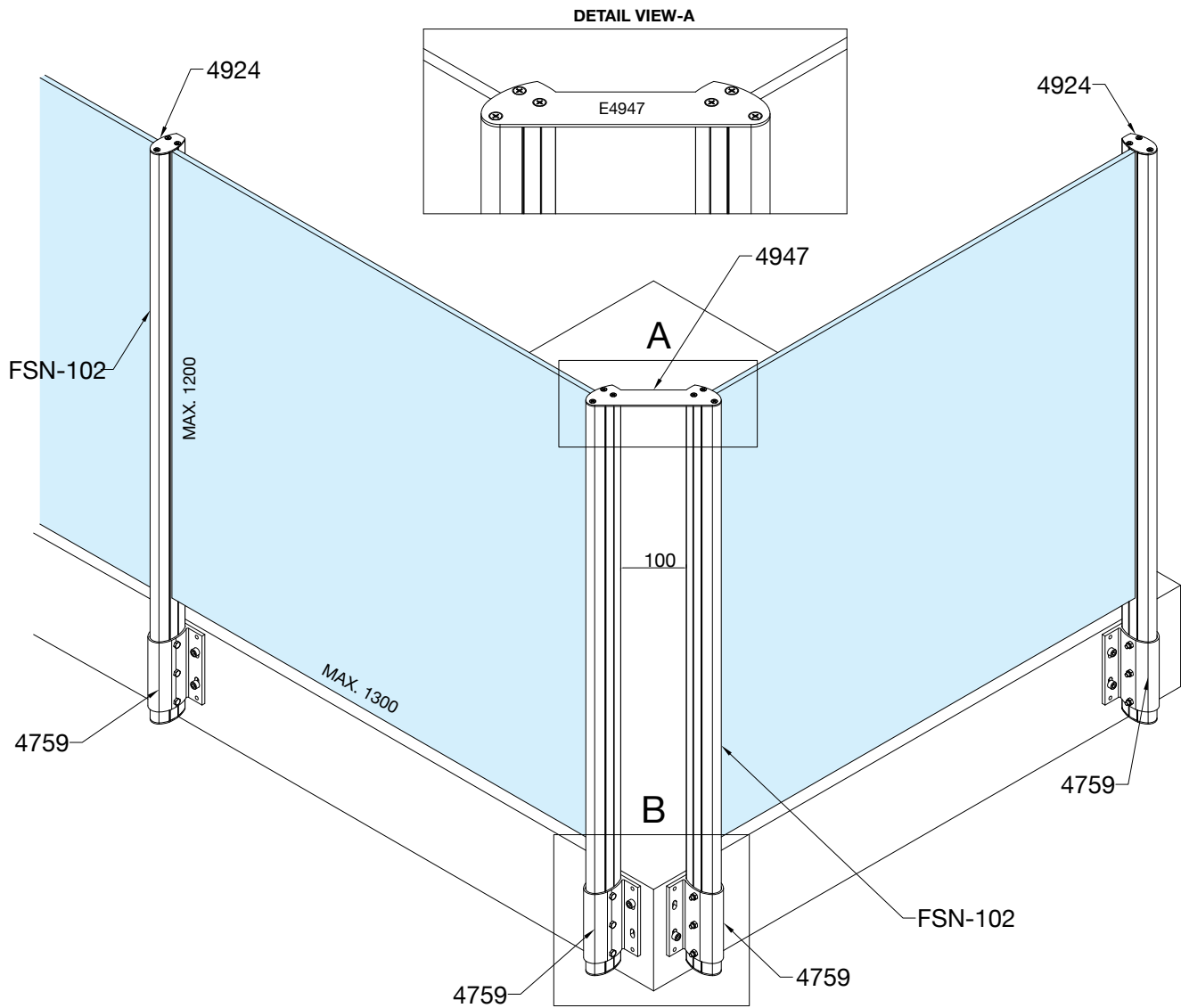

ΤΥΠΙΚΗ ΔΙΑΤΑΞΗ ΜΠΑΛΚΟΝΙΟΥ ΜΕ ΔΙΑΧΩΡΙΣΤΙΚΟ ΚΑΙ ΚΑΓΚΕΛΟ ORBIT 1 ΓΙΑ ΞΕΝΟΔΟΧΕΙΑ
 TYPICAL ORBIT 1 RAIL TYPE FOR HOTEL PARTITIONS

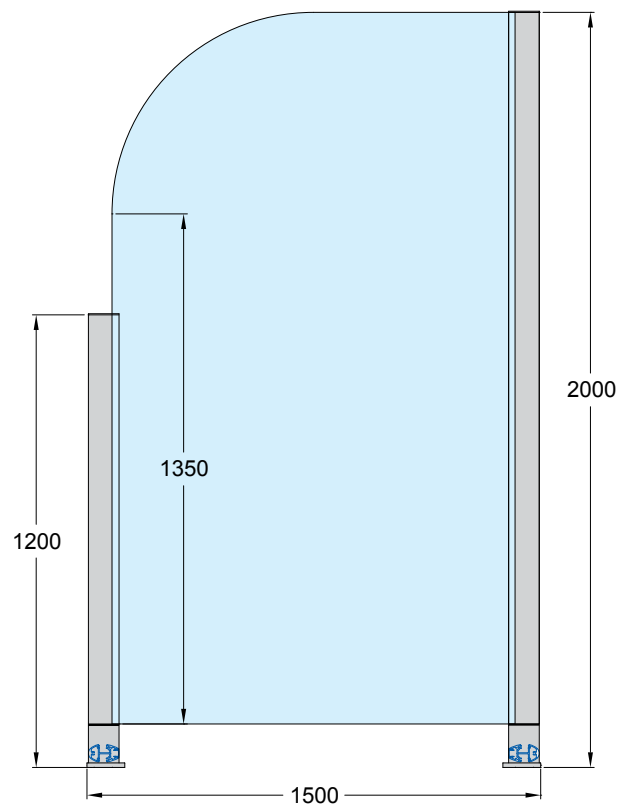
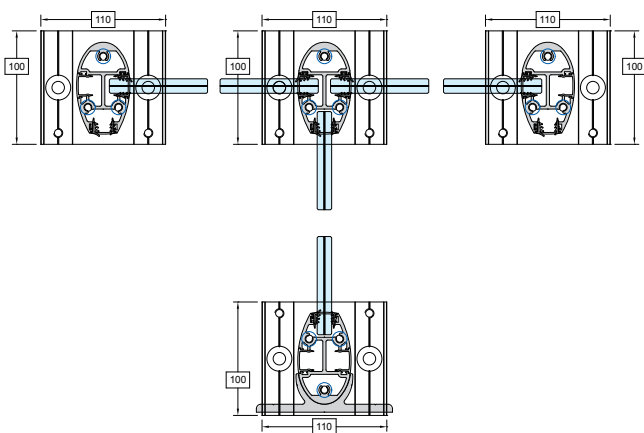
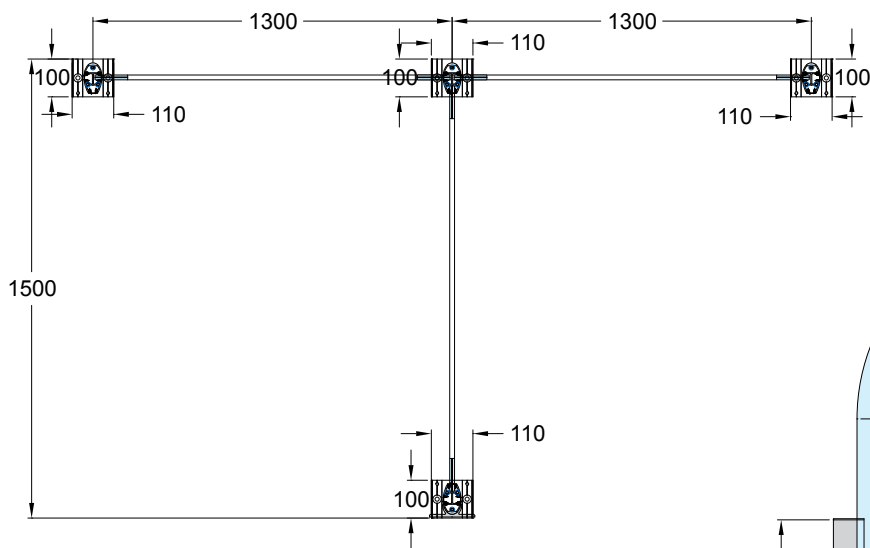
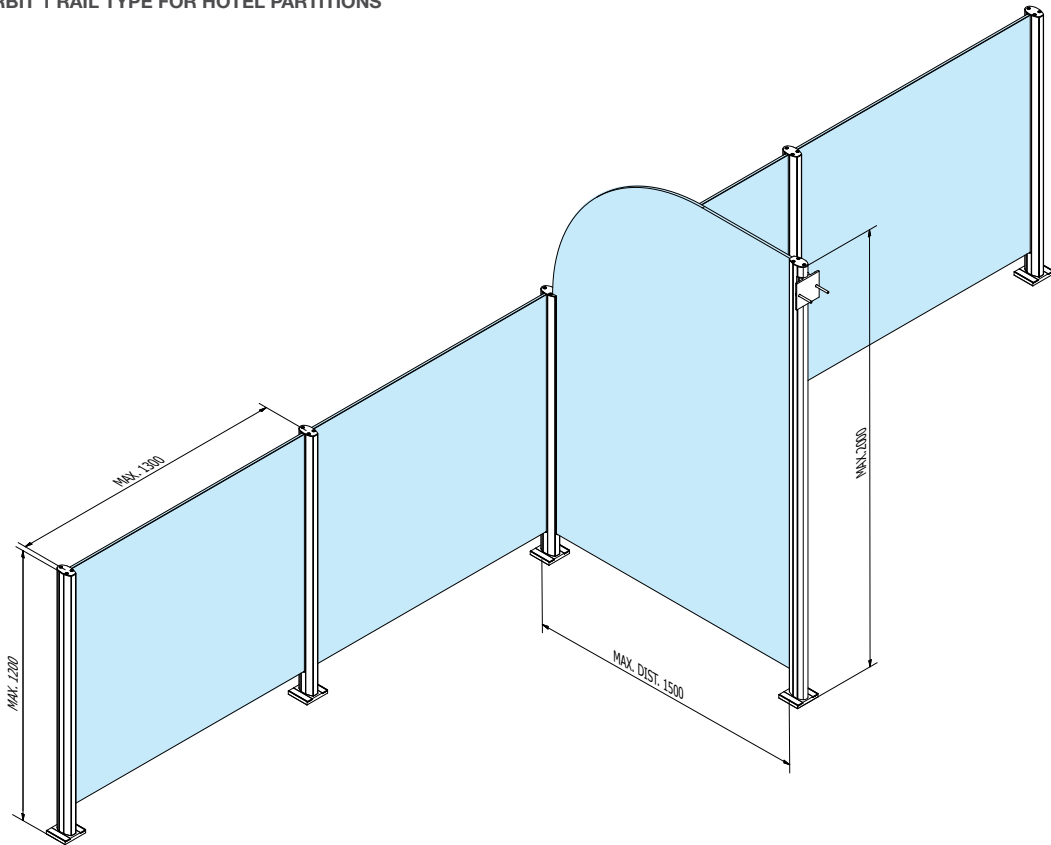

ΤΥΠΙΚΗ ΔΙΑΤΑΞΗ ΜΠΑΛΚΟΝΙΟΥ ΜΕ ΔΙΑΧΩΡΙΣΤΙΚΟ ORBIT 1 ΚΑΙ ΜΕ ΚΑΓΚΕΛΟ ΣΥΝΘΕΣΗΣ ΓΙΑ ΞΕΝΟΔΟΧΕΙΑ
 TYPICAL ORBIT 1 AND SYNTHESIS FOR HOTEL PARTITIONS

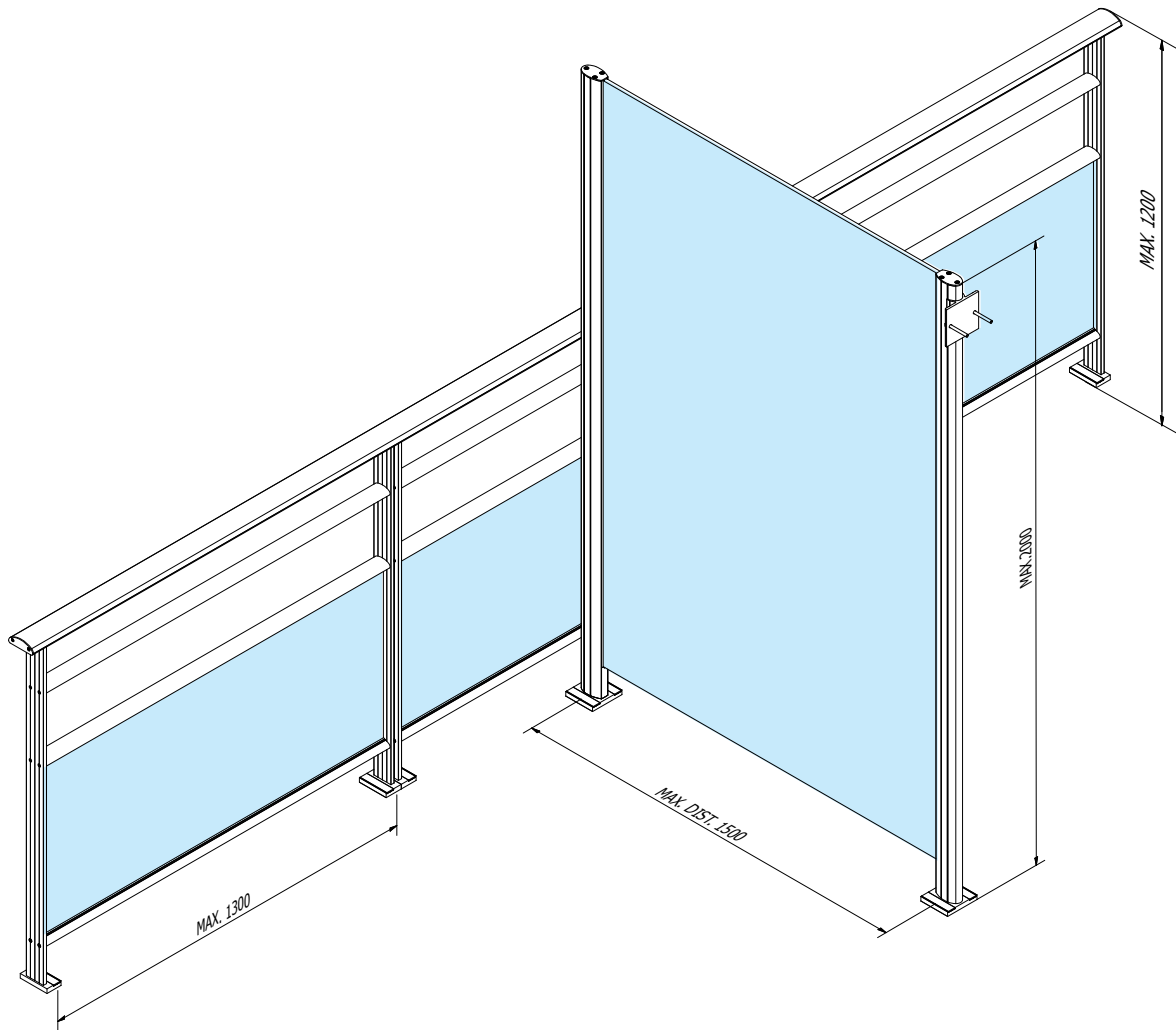

Orbit 1

Ground fixing guide



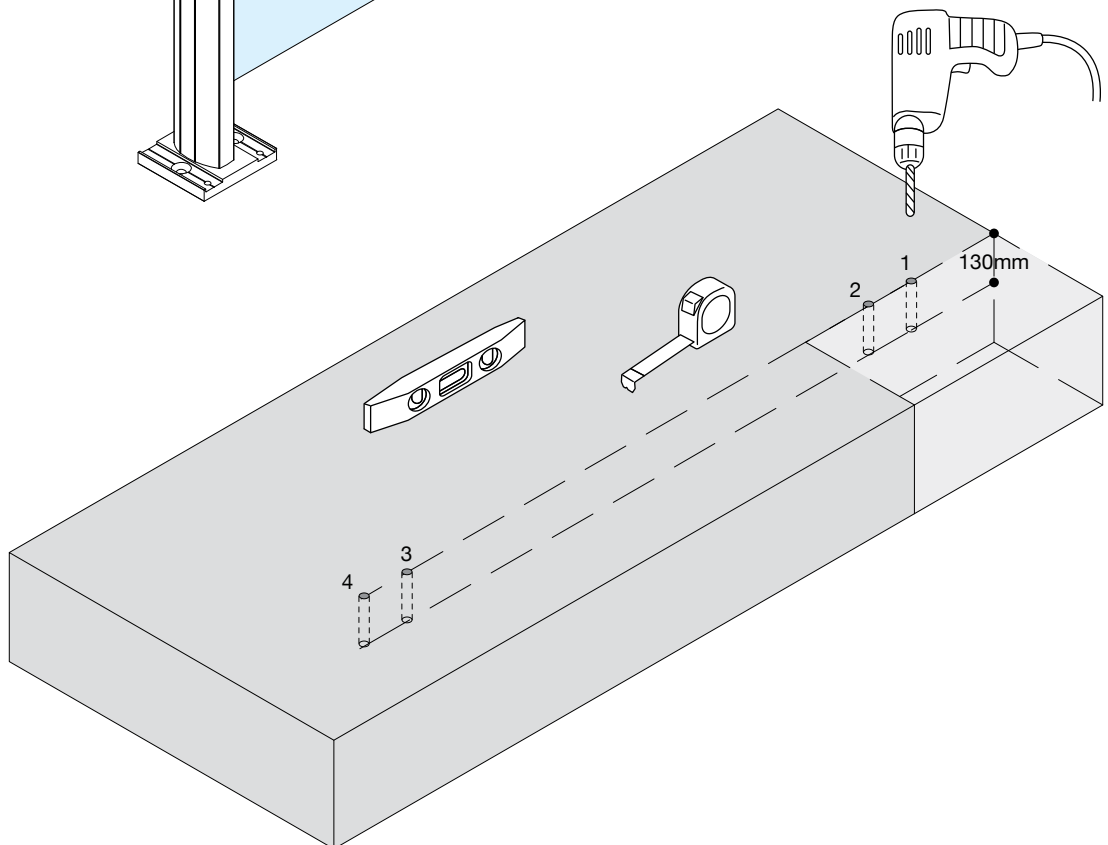
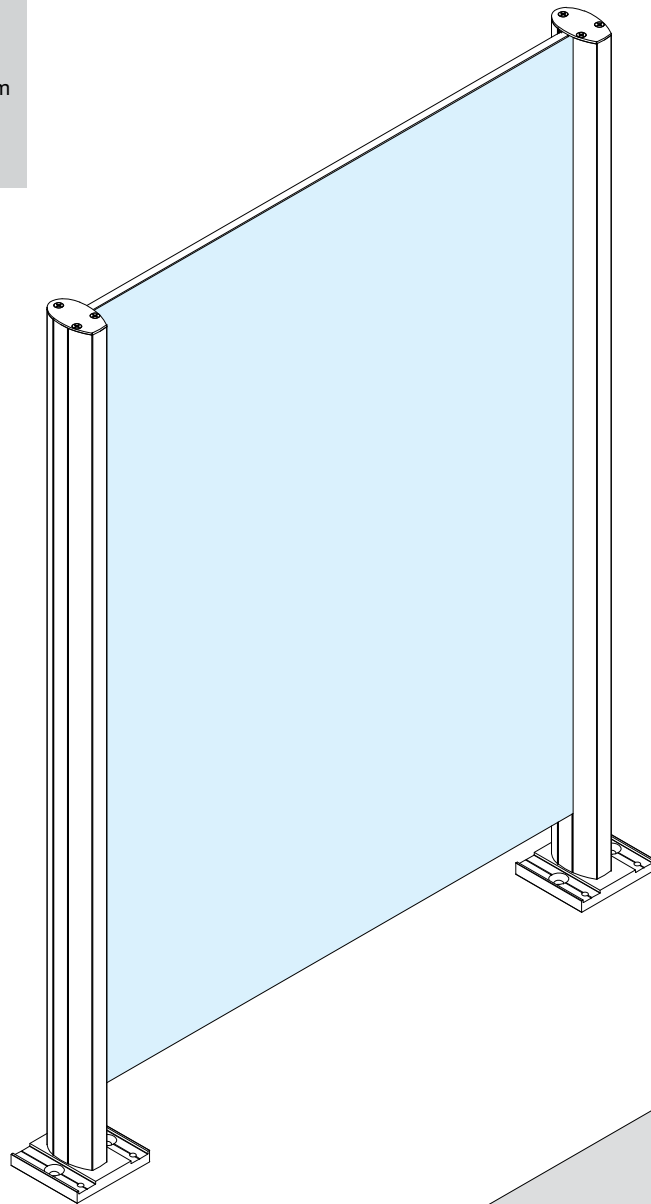
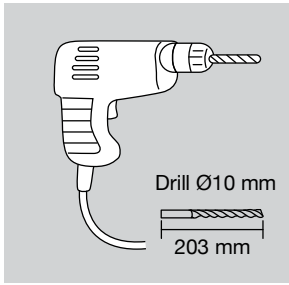

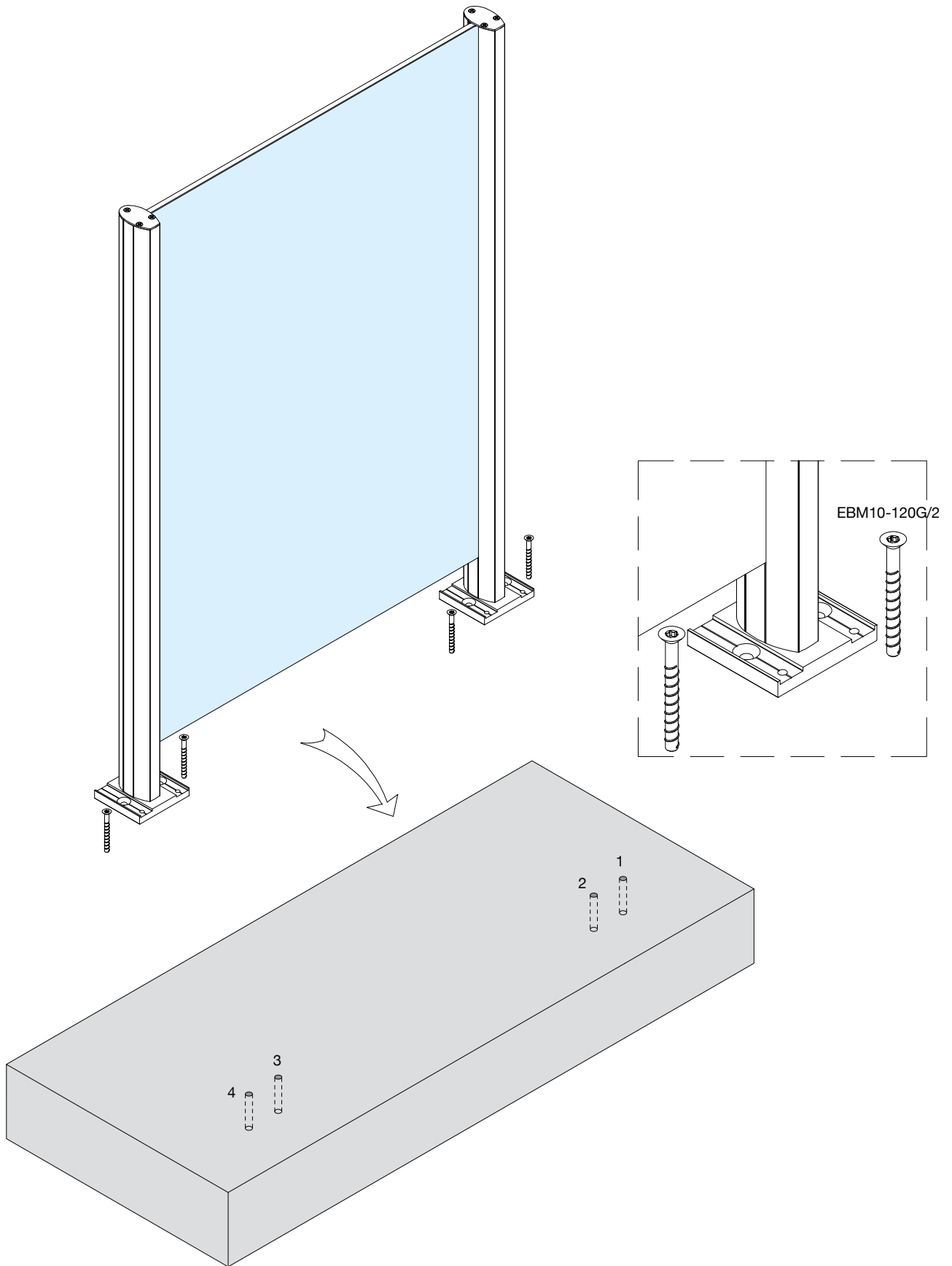

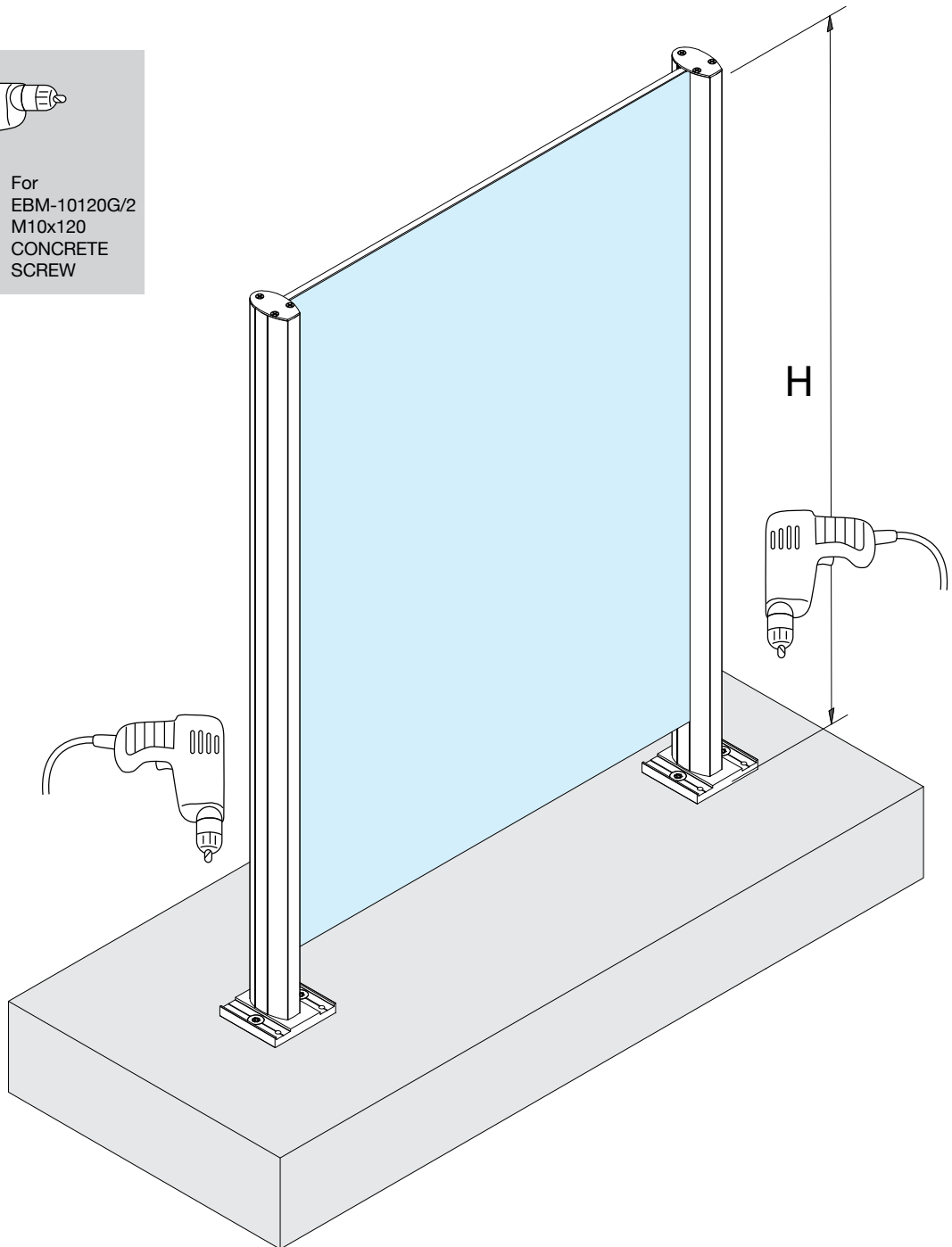

Orbit 2 Assembly

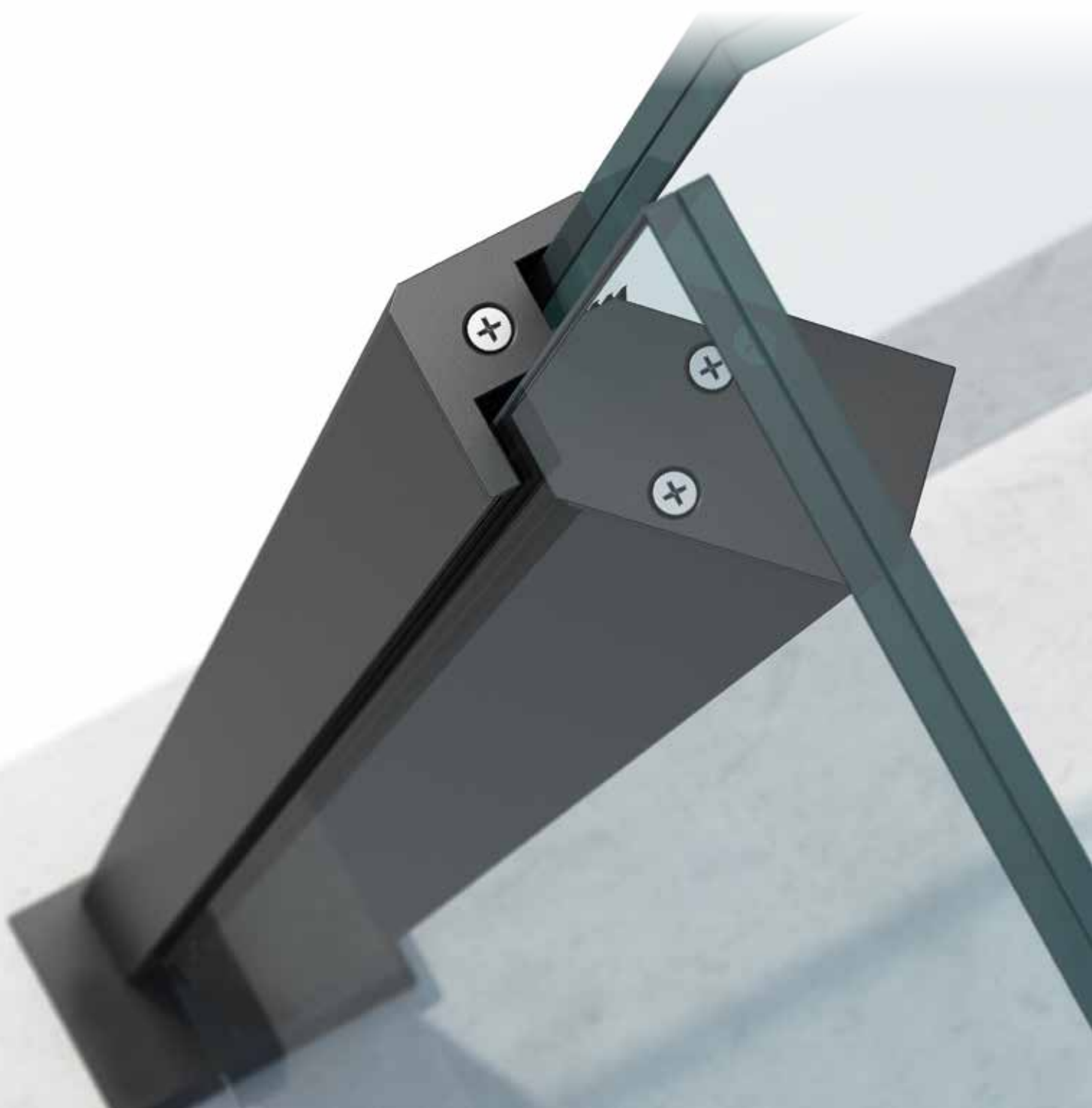

ΚΥΡΙΑ ΚΟΛΩΝΑ
MAIN POST

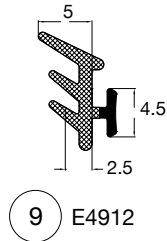

ΓΩΝΙΑΚΗ ΚΟΛΩΝΑ
CORNER POST

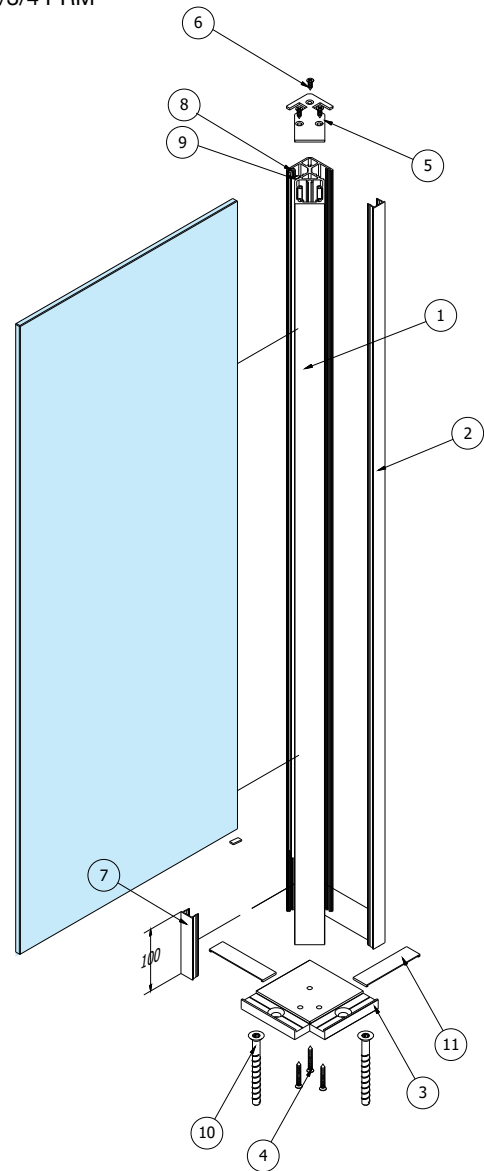
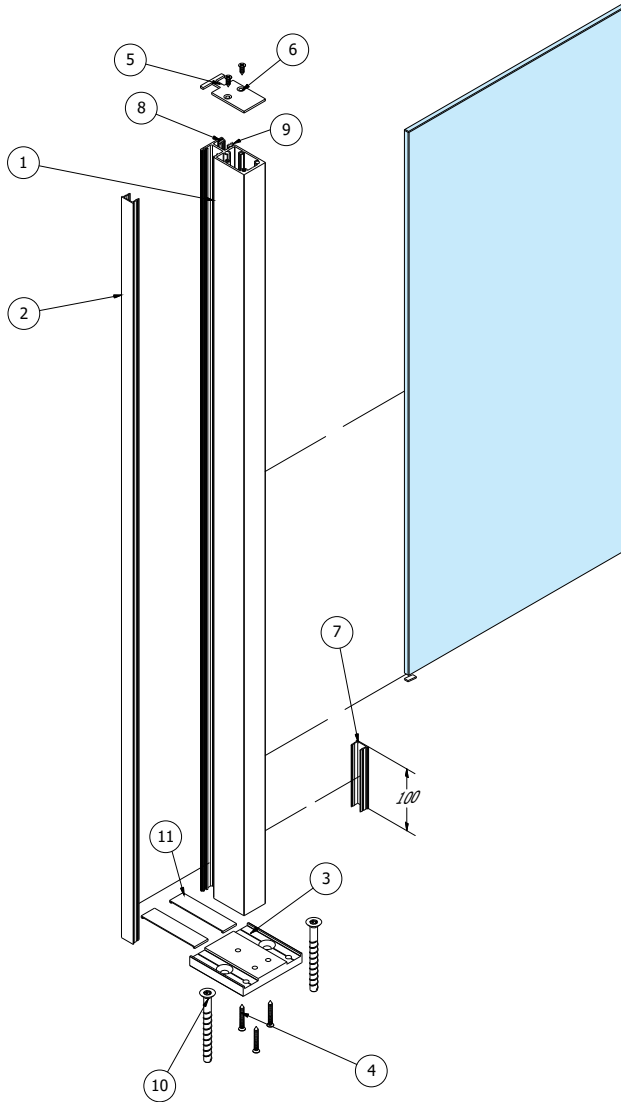

ΛΙΣΤΑ ΥΛΙΚΩΝ / PARTS LIST			
ΤΕΜ ΙΤΕΜ	ΠΟΣ/ΤΑ QTY	ΚΩΔ. ΕΞΑΡΤΗΜΑΤΟΣ PART NUMBER	DESCRIPTION / ΠΕΡΙΓΡΑΦΗ
1	1	FSN-103	ΚΟΛΩΝΑ ORBIT2 / ORBIT 2 POST
2	1	FSN-123	ΠΛΑΙΝΟ ΚΑΠΑΚΙ ΚΟΛΩΝΑΣ POST SIDE CAP
3	1	4714	ΠΕΛΑΜΑ ORBIT2 / ORBIT2 FOOTPLATE
4	3	DIN7982-6.3x50	ΒΙΔΕΣ ΠΕΛΜΑΤΟΣ / FOOTPLATE SCREWS
5	1	4933	ΑΝΩ ΤΑΠΑ ORBIT2 / ORBIT2 TOP COVER
6	2	DIN7982-A2-4.2x16	ΒΙΔΕΣ ΤΟΥ 4933 / 4933 SCREWS
7	1	FSN-123 (100MM)	ΑΠΟΣΤΑΤΗΣ ΥΑΛΟΠΙΝΑΚΑ GLASS STAND-OFF
8	1	E4912	ΛΑΣΤΙΧΟ / GASKET
9	1	US530-2/3/4 PRM	ΛΑΣΤΙΧΟ ΣΦΗΝΑ / GLAZING GASKET
10	2	EBM-10120G/2	ΜΠΕΤΟΒΙΔΙΑ / FISCHER CONCRETE SCREW
11	2	E4710	ΚΑΠΑΚΙ ΠΕΛΜΑΤΟΣ / FOOTPLATE COVER

ΛΙΣΤΑ ΥΛΙΚΩΝ / PARTS LIST			
ΤΕΜ ΙΤΕΜ	ΠΟΣ/ΤΑ QTY	ΚΩΔ. ΕΞΑΡΤΗΜΑΤΟΣ PART NUMBER	DESCRIPTION / ΠΕΡΙΓΡΑΦΗ
1	1	FSN-104	ΓΩΝΙΑΚΟ ΠΡΟΦΙΛ ΚΟΛΩΝΑΣ CORNER POST
2	1	FSN-123	ΠΛΑΙΝΟ ΚΑΠΑΚΙ ΚΟΛΩΝΑΣ POST SIDE CAP
3	1	4715	ΓΩΝ. ΠΕΛΑΜΑ ORBIT2 ORBIT2 FOOTPLATE
4	3	DIN7982-6.3x50	ΒΙΔΕΣ ΠΕΛΜΑΤΟΣ FOOTPLATE SCREWS
5	1	4935	ΑΝΩ ΤΑΠΑ ORBIT2 ORBIT2 TOP COVER
6	3	DIN7982-A2-4.2X16	ΒΙΔΕΣ ΤΟΥ 4933 / 4935 SCREWS
7	1	FSN-123 (100 mm)	ΑΠΟΣΤΑΤΗΣ ΥΑΛΟΠΙΝΑΚΑ GLASS STAND-OFF
8	1	E4912	ΛΑΣΤΙΧΟ / GASKET
9	1	US530-2/3/4 PRM	ΛΑΣΤΙΧΟ ΣΦΗΝΑ / GLAZING GASKET
10	2	EBM-10120G/2	ΜΠΕΤΟΒΙΔΙΑ / FISCHER CONCRETE SCREW
11	2	E4710	ΚΑΠΑΚΙ ΠΕΛΜΑΤΟΣ / FOOTPLATE COVER

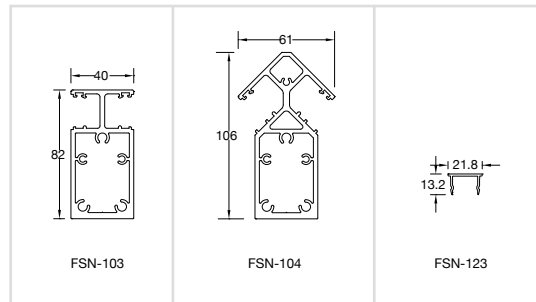
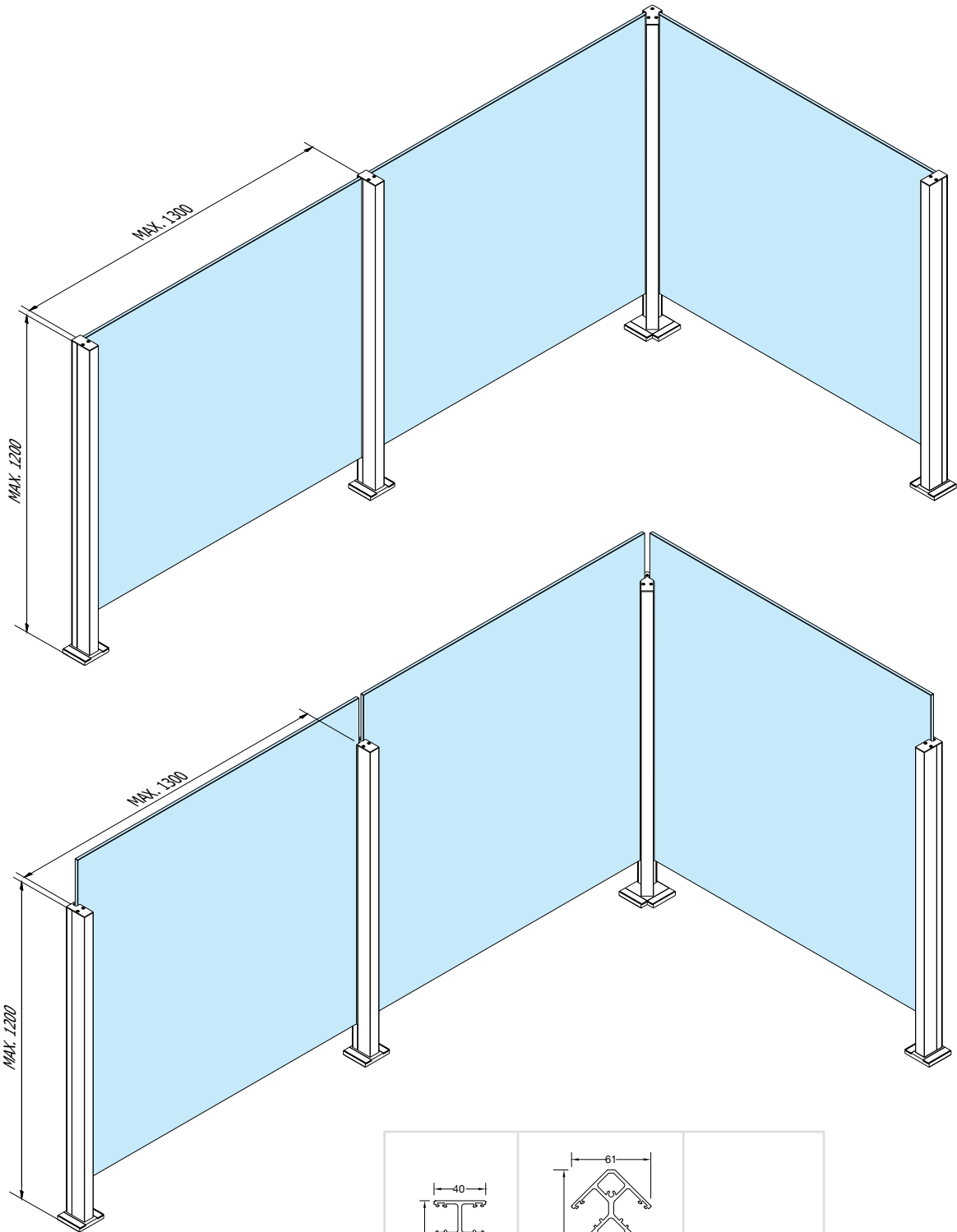

MAIN POST 1 m

TWO WAY GLASS PANES

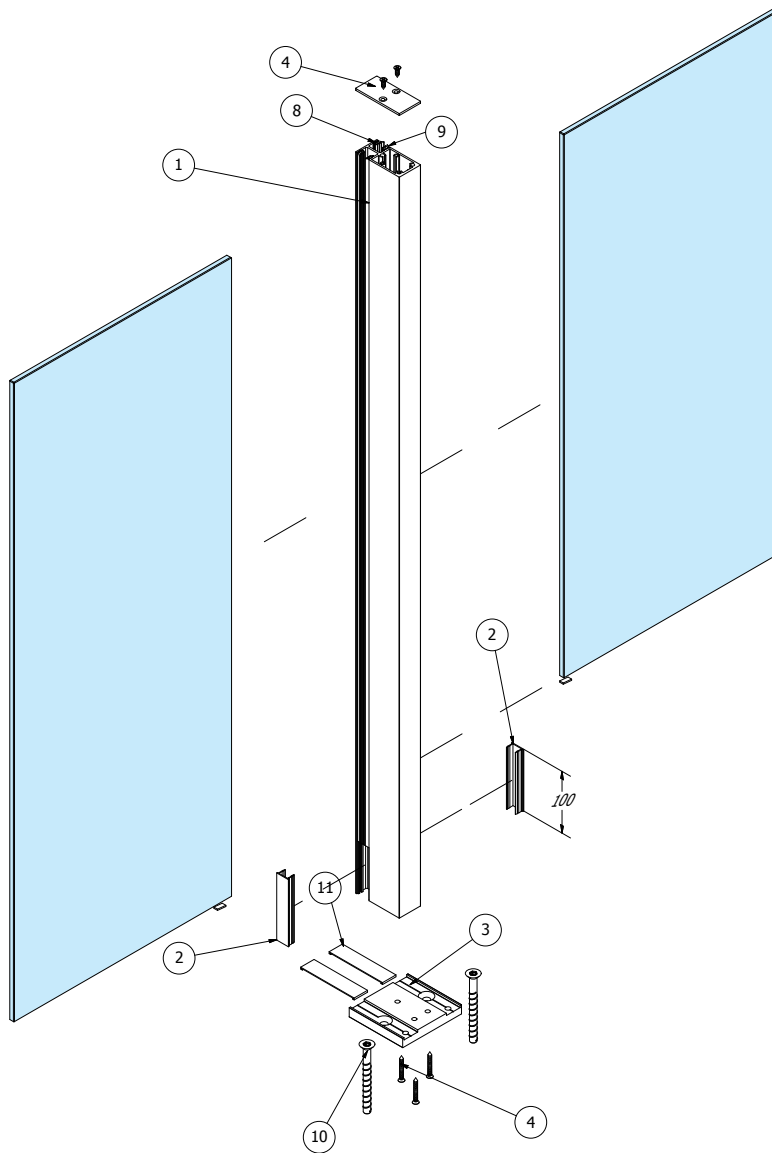

ΛΙΣΤΑ ΥΛΙΚΩΝ / PARTS LIST			
ΤΕΜ ΙΤΕΜ	ΠΟΣ/ΤΑ QTY	ΚΩΔ. ΕΞΑΡΤΗΜΑΤΟΣ PART NUMBER	DESCRIPTION / ΠΕΡΙΓΡΑΦΗ
1	1	FSN-103	ΚΟΛΩΝΑ ORBIT 2 / ORBIT 2 POST
2	2	FSN-123 (100MM)	ΑΠΟΣΤΑΤΗΣ ΥΑΛΟΠΙΝΑΚΑ GLASS STAND-OFF
3	1	4714	ORBIT2 ΠΕΛΜΑ / ORBIT2 FOOTPLATE
4	1	4930	ΑΝΩ ΤΑΠΑ ORBIT2 / ORBIT2 TOP COVER
8	2	E4912	ΛΑΣΤΙΧΟ / GASKET
9	2	US530-1/2/3/4 PRM	ΛΑΣΤΙΧΟ ΣΦΗΝΑ / GLAZING GASKET
10	2	EBM-10120G/2	ΜΠΕΤΟΒΙΔΑ / FISCHER CONCRETE SCREW
11	2	4710	ΚΑΠΑΚΙ ΠΕΛΜΑΤΟΣ / FOOTPLATE COVER

ONLY POST

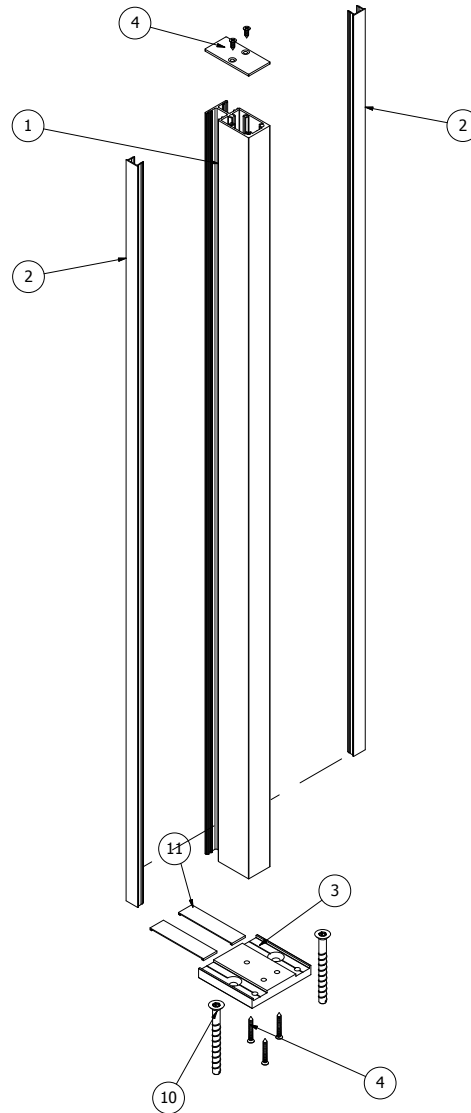

ΛΙΣΤΑ ΥΛΙΚΩΝ / PARTS LIST			
ΤΕΜ ΙΤΕΜ	ΠΟΣ/ΤΑ QTY	ΚΩΔ. ΕΞΑΡΤΗΜΑΤΟΣ PART NUMBER	DESCRIPTION / ΠΕΡΙΓΡΑΦΗ
1	1	FSN-103	ΚΟΛΩΝΑ ORBIT 2 / ORBIT 2 POST
2	2	FSN-123	ΠΛΑΙΝΟ ΚΑΠΑΚΙ ΚΟΛΩΝΑΣ POST SIDE CAP
3	1	4714	ΠΕΛΜΑ ORBIT2 / ORBIT2 FOOTPLATE
4	1	4930	ΑΝΩ ΤΑΓΙΑ ORBIT 2 / ORBIT 2 TOP COVER
10	2	EBM-10120G/2	ΜΠΕΤΟΒΙΔΑ / FISCHER CONCRETE SCREW
11	2	4710	ΚΑΠΑΚΙ ΠΕΛΜΑΤΟΣ / FOOTPLATE COVER

ΓΩΝΙΑΚΗ ΚΟΛΩΝΑ CORNER POST

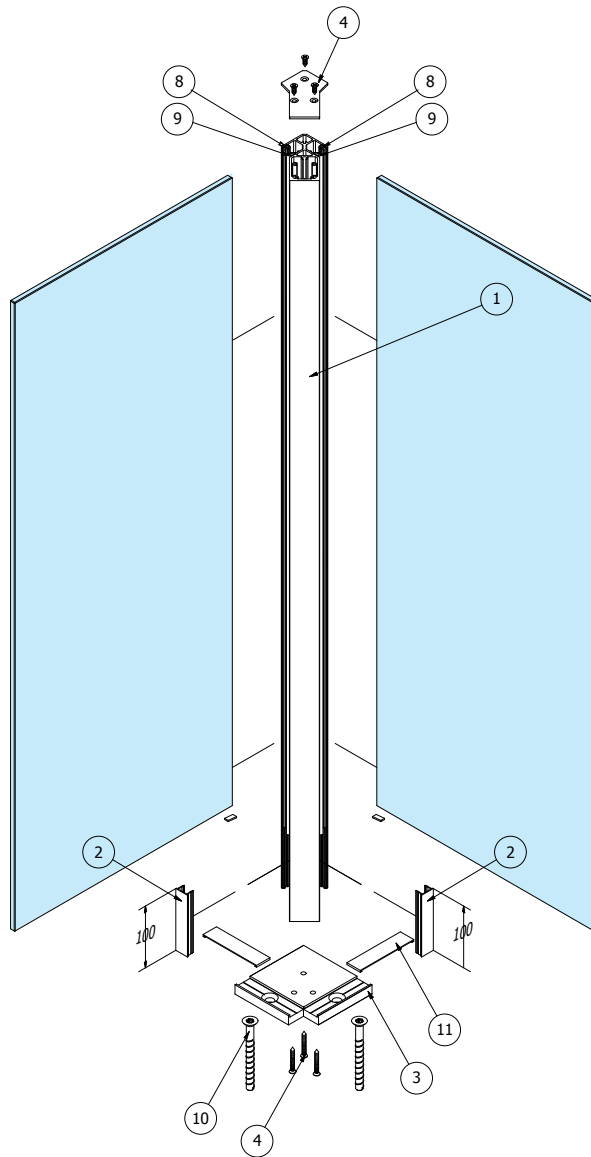

ΛΙΣΤΑ ΥΛΙΚΩΝ / PARTS LIST

ΤΕΜ ΙΤΕΜ	ΠΟΣ/ΤΑ QTY	ΚΩΔ. ΕΞΑΡΤΗΜΑΤΟΣ PART NUMBER	DESCRIPTION / ΠΕΡΙΓΡΑΦΗ
1	1	FSN-104	ΓΩΝΙΑΚΗ ΚΟΛΩΝΑ ORBIT 2 / ORBIT 2 CORNER POST
2	2	FSN-123 (100MM)	ΑΠΟΣΤΑΤΗΣ ΥΑΛΟΠΙΝΑΚΑ GLASS STAND-OFF
3	1	4715	ORBIT2 ΠΕΛΜΑ / ORBIT2 FOOTPLATE
4	1	4934	ΑΝΩ ΤΑΠΑ ORBIT2 / ORBIT2 TOP COVER
8	2	E4912	ΛΑΣΤΙΧΟ / GASKET
9	2	US530-1/2/3/4 PRM	ΛΑΣΤΙΧΟ ΣΦΗΝΑ / GLAZING GASKET
10	2	EBM-10120G/2	ΜΠΙΕΤΟΒΙΔΑ / FISCHER CONCRETE SCREW
11	2	4710	ΚΑΠΑΚΙ ΠΕΛΜΑΤΟΣ / FOOTPLATE COVER

**ΚΥΡΙΑ ΚΟΛΩΝΑ
MAIN POST**

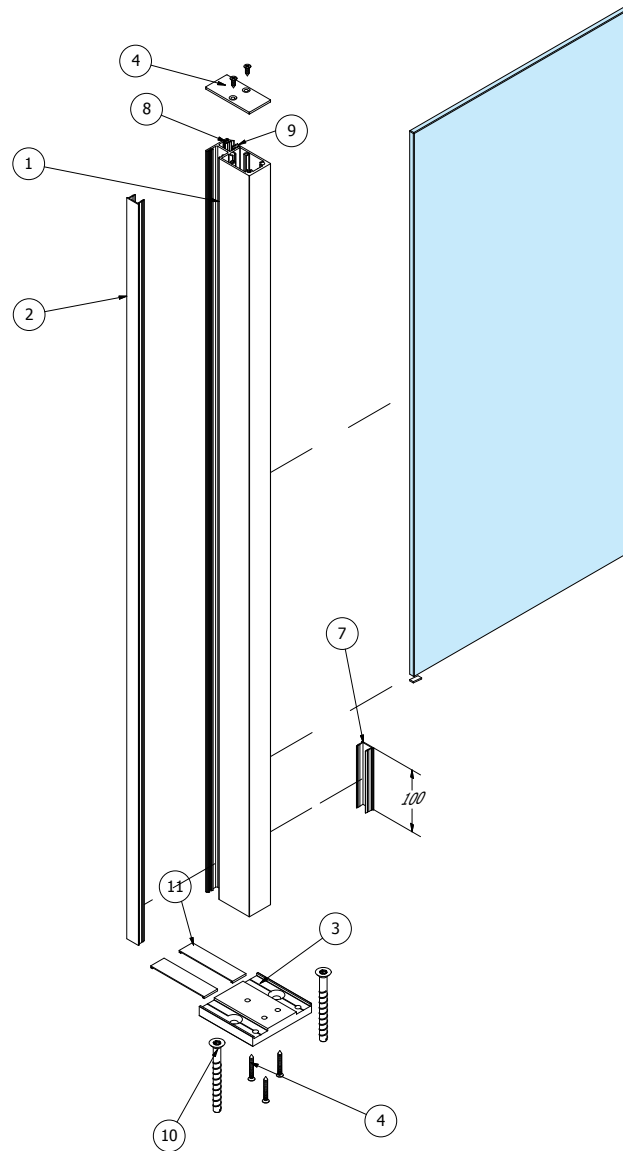

ΛΙΣΤΑ ΥΛΙΚΩΝ / PARTS LIST			
ΤΕΜ ΙΤΕΜ	ΠΟΣ/ΤΑ QTY	ΚΩΔ. ΕΞΑΡΤΗΜΑΤΟΣ PART NUMBER	DESCRIPTION / ΠΕΡΙΓΡΑΦΗ
1	1	FSN-103	ΚΟΛΩΝΑ ORBIT 2 / ORBIT 2 POST
2	2	FSN-123	ΠΛΑΙΝΟ ΚΑΠΑΚΙ ΚΟΛΩΝΑΣ POST SIDE CAP
3	1	4714	ORBIT2 ΠΕΛΜΑ / ORBIT2 FOOTPLATE
4	1	4930	ΑΝΩ ΤΑΠΑ ORBIT2 / ORBIT2 TOP COVER
8	2	E4912	ΛΑΣΤΙΧΟ / GASKET
9	2	US530-1/2/3/4 PRM	ΛΑΣΤΙΧΟ ΣΦΗΝΑ / GLAZING GASKET
10	2	EBM-10120G/2	ΜΠΕΤΟΒΙΔΑ / FISCHER CONCRETE SCREW
11	2	4710	ΚΑΠΑΚΙ ΠΕΛΜΑΤΟΣ / FOOTPLATE COVER

ΓΩΝΙΑΚΗ ΚΟΛΩΝΑ CORNER POST

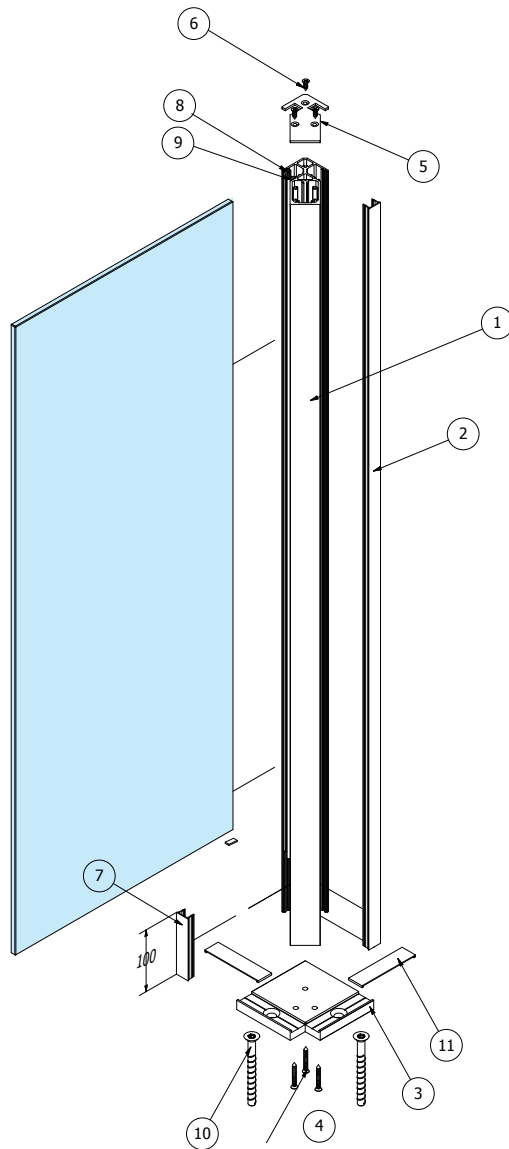

ΛΙΣΤΑ ΥΛΙΚΩΝ / PARTS LIST			
ΤΕΜ ΙΤΕΜ	ΠΟΣ/ΤΑ QTY	ΚΩΔ. ΕΞΑΡΤΗΜΑΤΟΣ PART NUMBER	DESCRIPTION / ΠΕΡΙΓΡΑΦΗ
1	1	FSN-104	ΓΩΝΙΑΚΗ ΚΟΛΩΝΑ ORBIT 2 ORBIT 2 CORNER POST
2	1	FSN-123	ΠΛΑΙΝΟ ΚΑΠΑΚΙ ΚΟΛΩΝΑΣ POST SIDE CAP
3	1	4715	ORBIT2 ΠΕΛΜΑ / ORBIT2 FOOTPLATE
4	3	DIN7982-6.3x50	ΒΙΔΕΣ ΠΕΛΜΑΤΟΣ / FOOTPLATE SCREWS
5	1	4935	ΑΝΩ ΤΑΠΑ ORBIT2 / ORBIT2 TOP COVER
6	3	DIN7982-A2-4.2x16	ΒΙΔΕΣ ΤΟΥ 4935 / 4935 SCREWS
7	1	FSN-123 (100MM)	ΑΠΟΣΤΑΤΗΣ ΥΑΛΟΠΙΝΑΚΑ GLASS STAND-OFF
8	1	E4912	ΛΑΣΤΙΧΟ / GASKET
9	1	US530-1/2/3/4 PRM	ΛΑΣΤΙΧΟ ΣΦΗΝΑ / GLAZING GASKET
10	2	EBM-10120G/2	ΜΠΕΤΟΒΙΔΑ / FISCHER CONCRETE SCREW
11	2	4710	ΚΑΠΑΚΙ ΠΕΛΜΑΤΟΣ / FOOTPLATE COVER

SIDE MOUNT-CORNER ORBIT-02

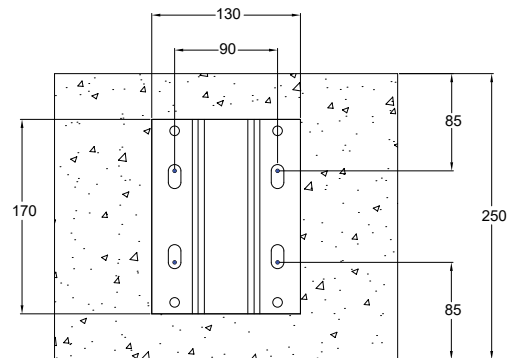
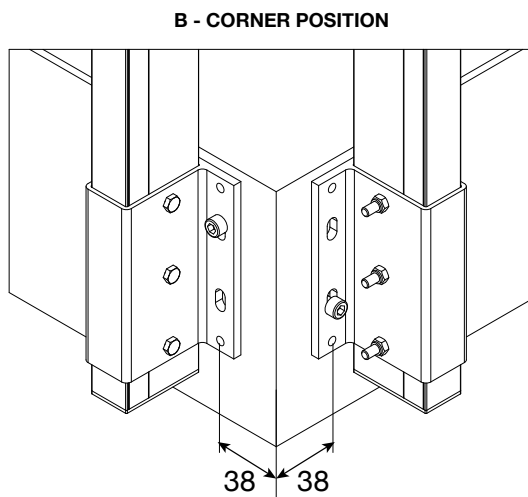
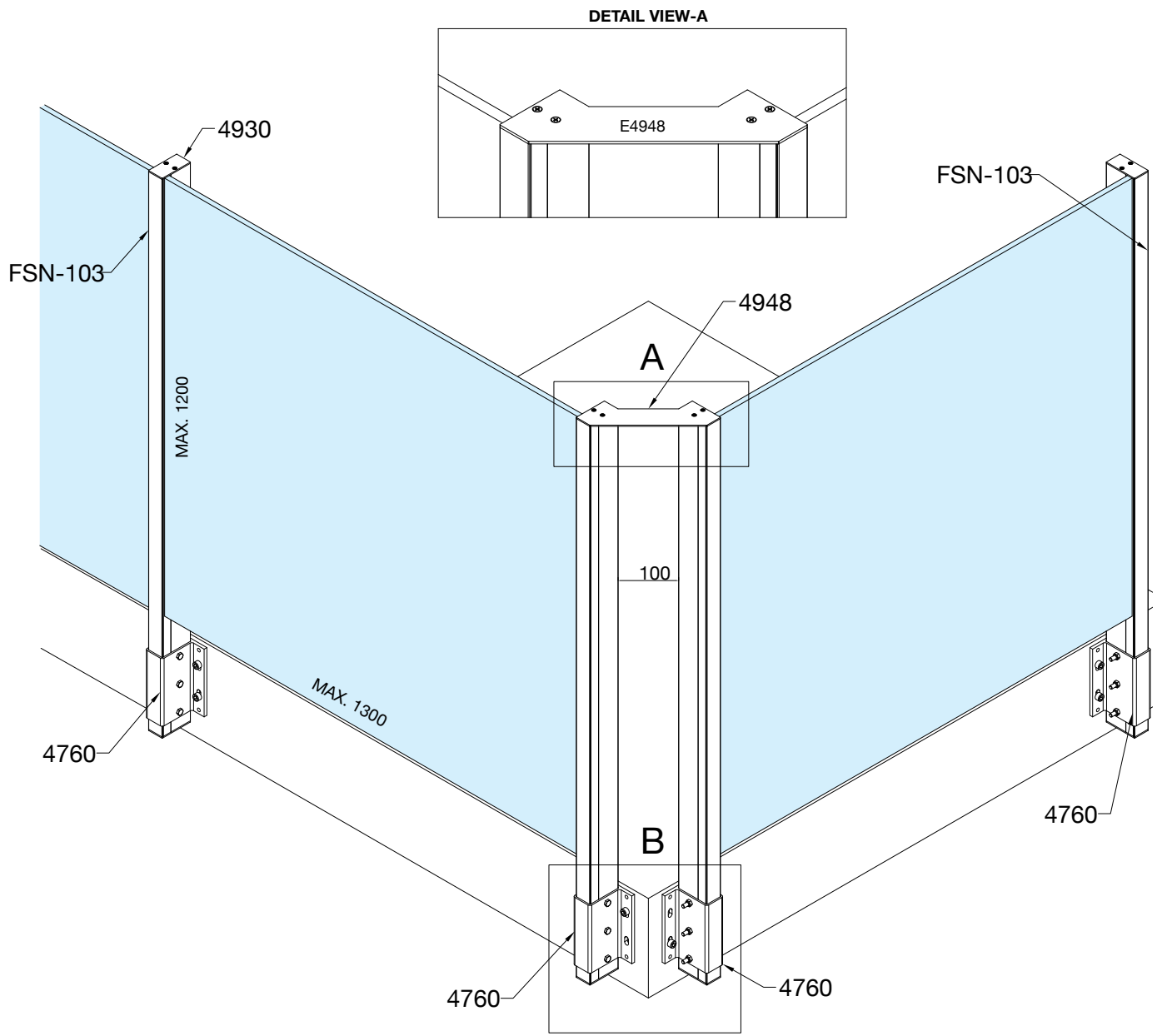

Orbit 2

Ground fixing guide

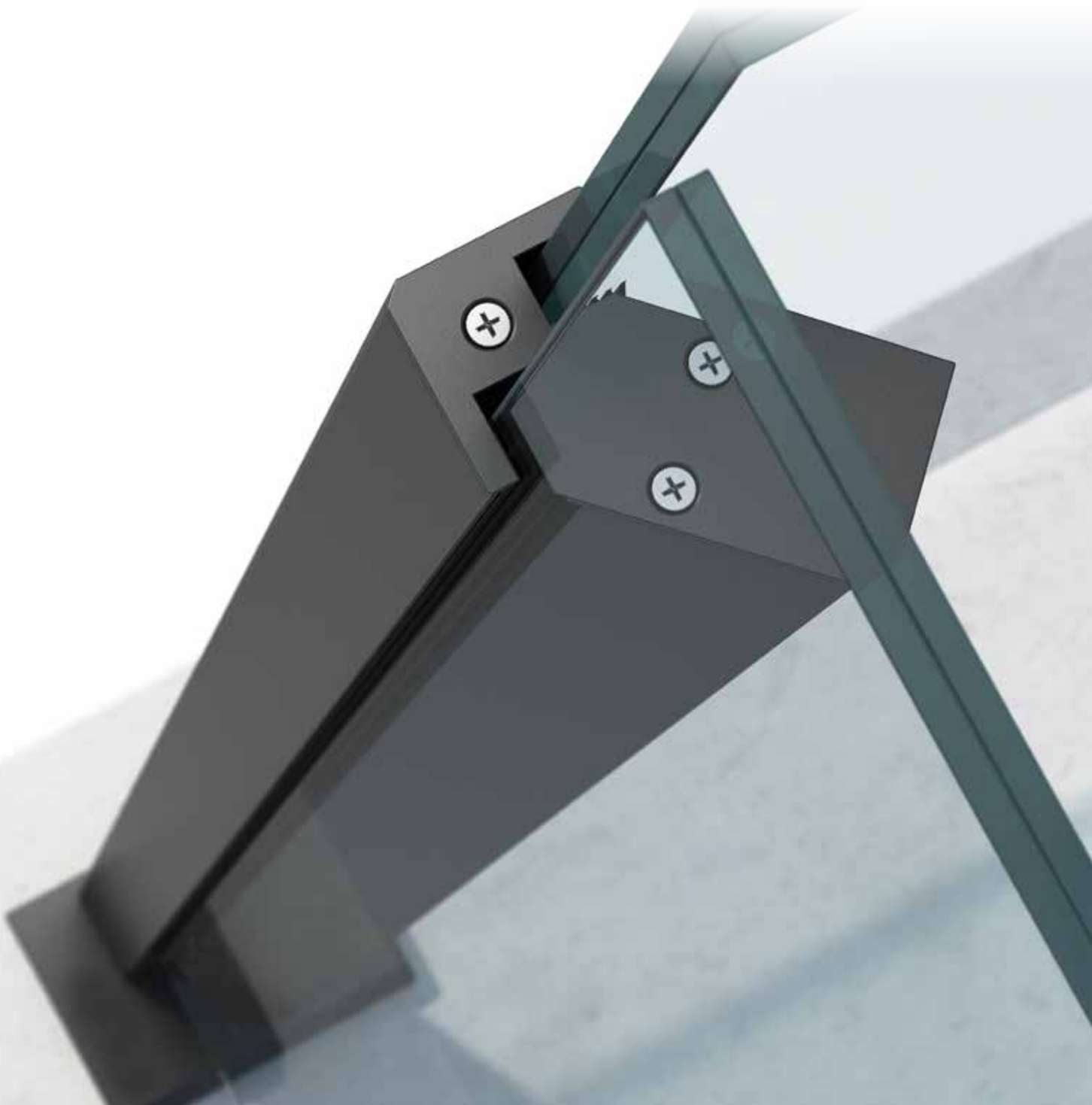

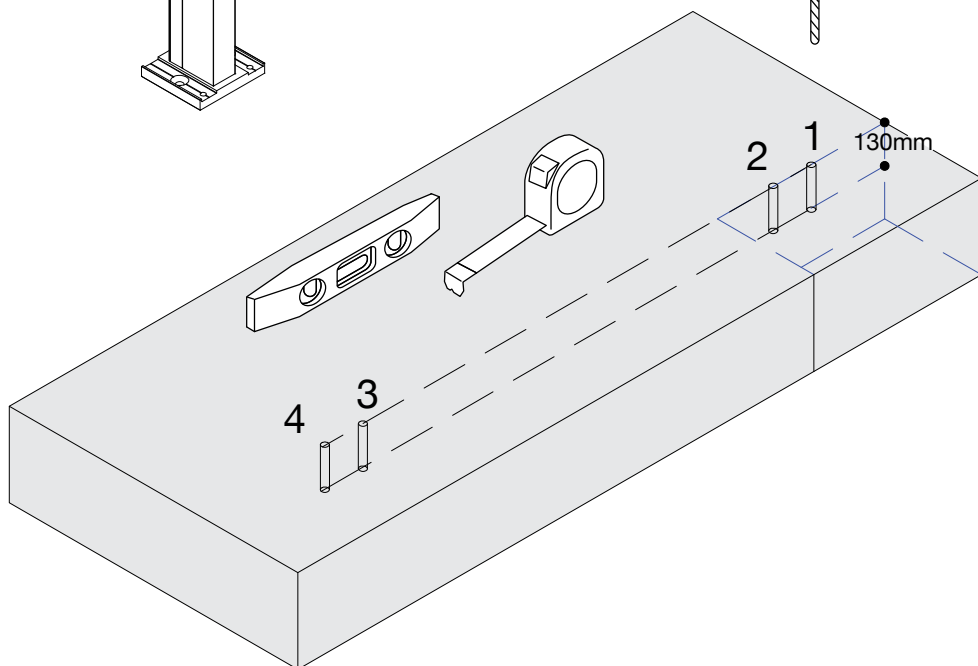
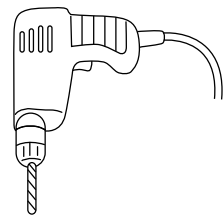
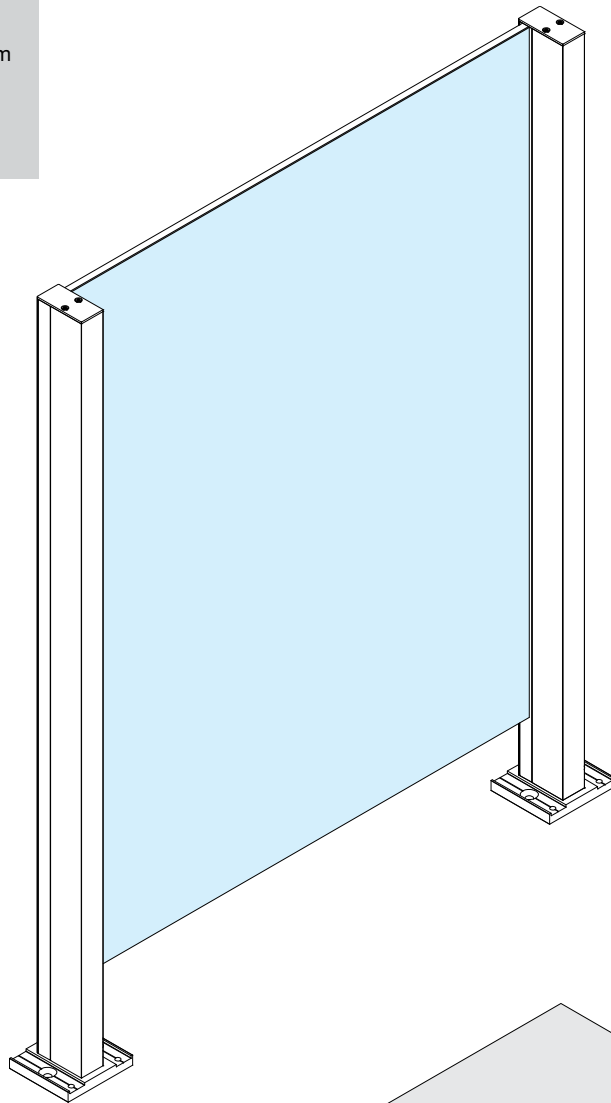
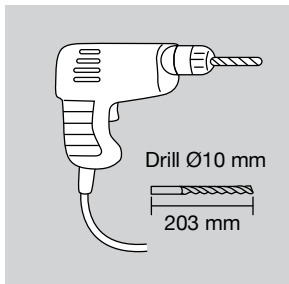

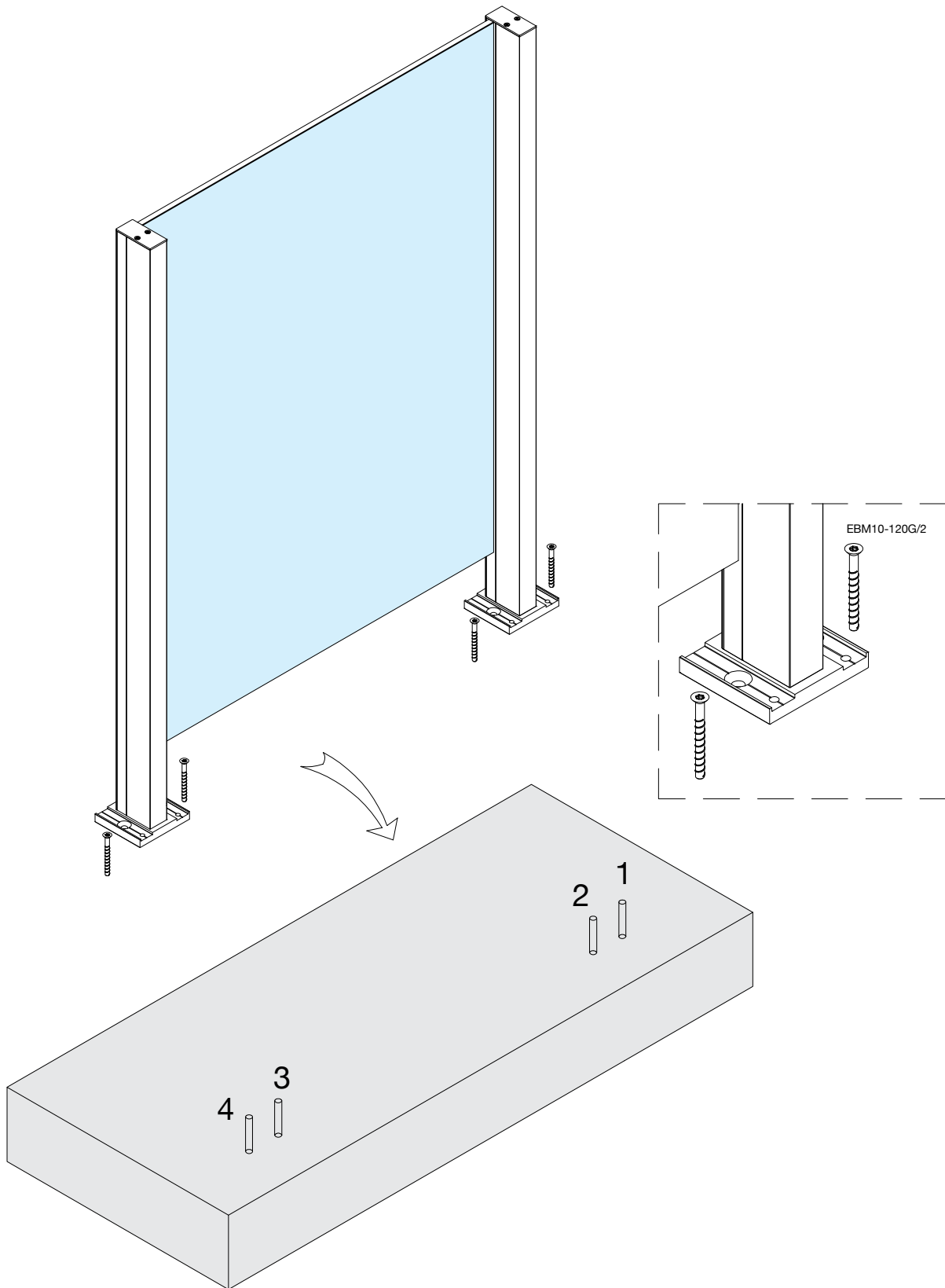

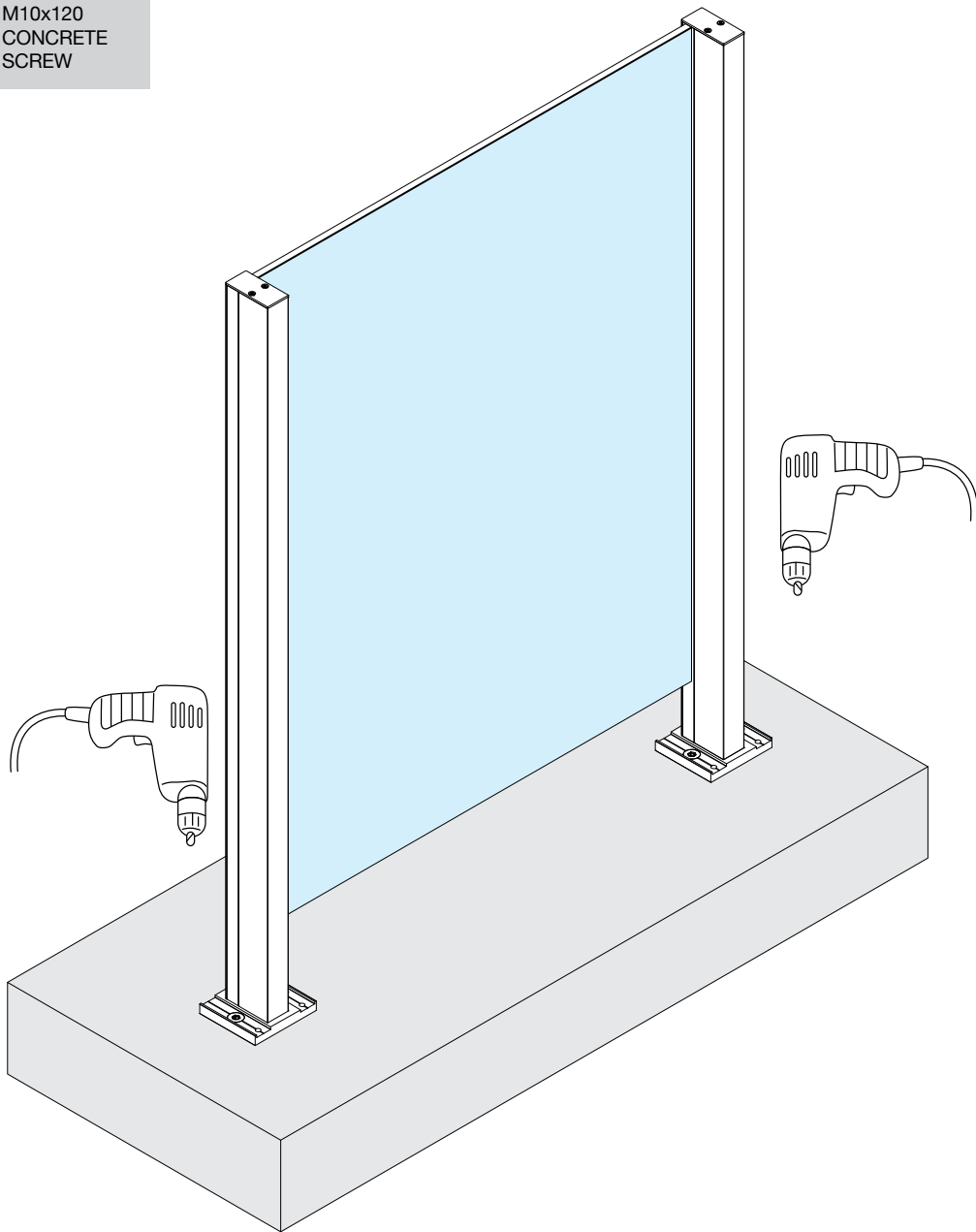

Οδηγίες συγκράτησης του υαλοπίνακα στους τύπους των Orbit / Guidelines for glass panel support in Orbit types

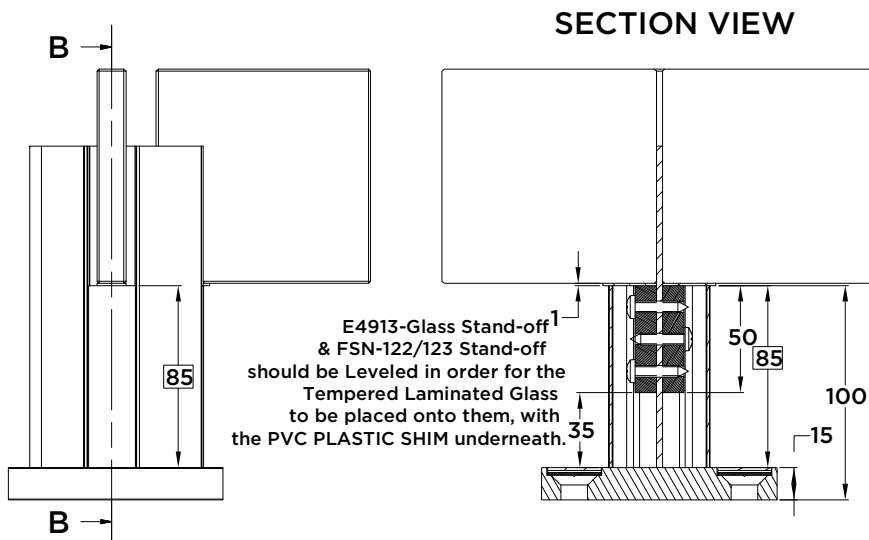
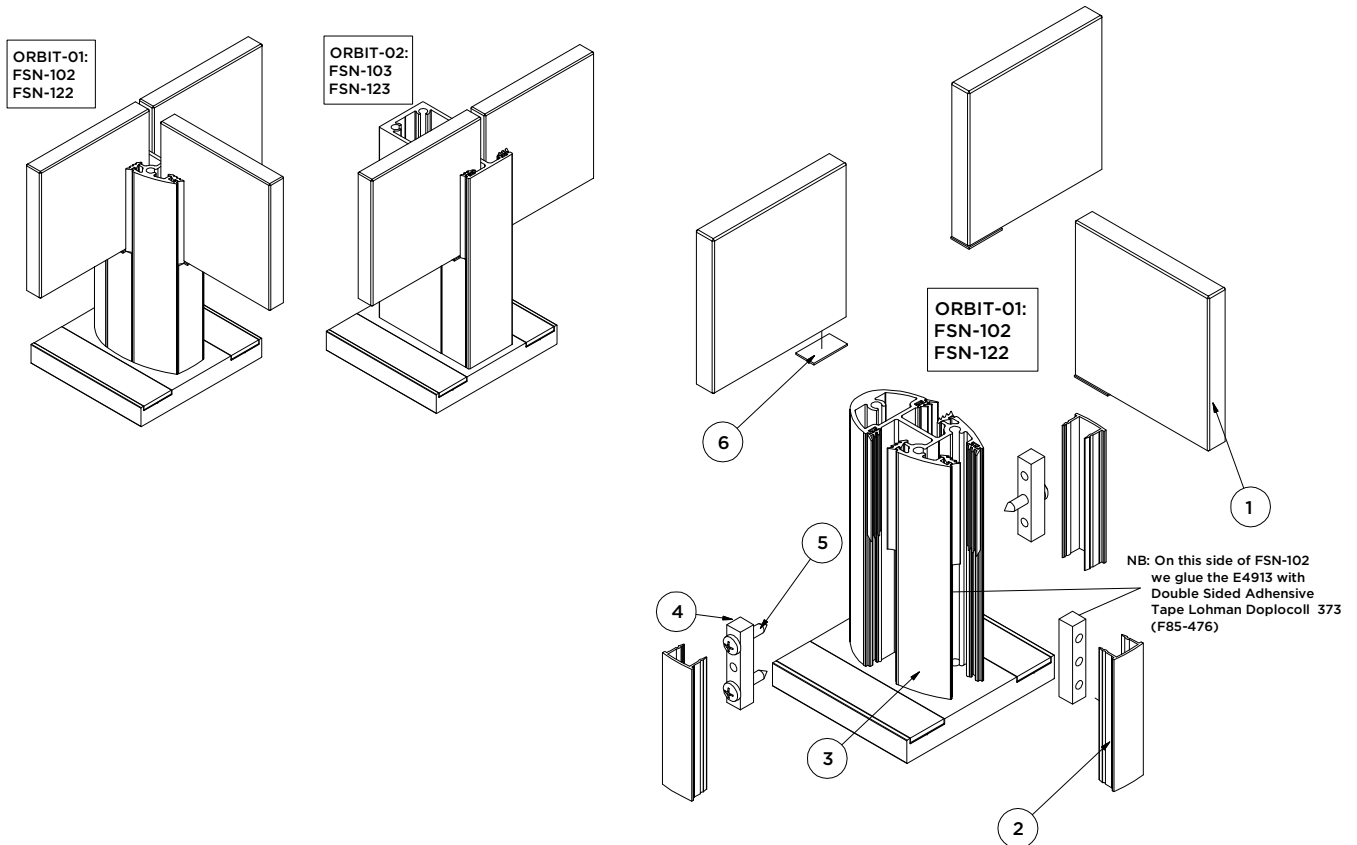

* Exactly the same fixation applies also for ORBIT-02: FSN-103/123

Τεμάχια Item	Ποσότητα Qty	Κωδικός Part Number	Περιγραφή Description
1	3	-	Tempered Laminated Glass 13.52mm Glass Panel TSG
2	3	FSN-122 / FSN-123	Glass Panel Stand-Off
3	1	FSN-102 / FSN-103	ORBIT-01 POST
4	3	E4913	INFILL WITH SCREWS
5	3	DIN 7504N - 5,5 x 25	(Sheetmetal) Tapping Screw
6	3	F85-410, or F85-411, or F85-020, or F85-021	Glass Panel Shim 1mm

- * F85-410 ->1mm PVC WHITE sheet 2m to be cut to pieces of 14x25x1mm, or
- * F85-411 ->1mm PVC WHITE sheet 2m to be cut to pieces of 14x25x1mm, or
- * F85-E020 ->1mm PVC WHITE sheet 150mm to be cut to pieces of 14x25x1mm, or
- * F85-E021 ->1mm PVC WHITE sheet 300mm to be cut to pieces of 14x25x1mm.

Orbit

Profiles & Accessories



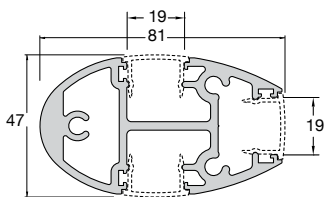

Κωδικός / Code: **FSN-102**

ΒΑΡΟΣ / WEIGHT: 2384 gr/m
 ΚΟΛΩΝΑ ΟΒΑΛ 45x80
 COLUMN OVAL 45x80

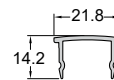

Κωδικός / Code: **FSN-122**

ΒΑΡΟΣ / WEIGHT: 163 gr/m
 ΚΑΠΑΚΙ ΚΟΛΩΝΑΣ FSN-102
 COVER FOR COLUMN FSN-102

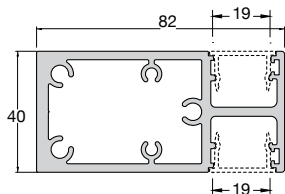

Κωδικός / Code: **FSN-103**

ΒΑΡΟΣ / WEIGHT: 2367 gr/m
 ΚΟΛΩΝΑ 40x82 (ΧΩΡΙΣ ΚΑΠΑΚΙ)
 COLUMN 40x82 (WITHOUT CAP)

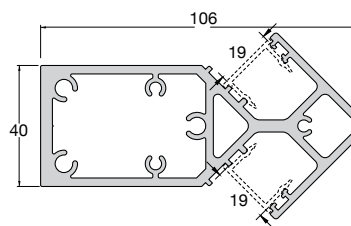

Κωδικός / Code: **FSN-104**

ΒΑΡΟΣ / WEIGHT: 3118 gr/m
 ΓΩΝΙΑΚΗ ΚΟΛΩΝΑ
 COLUMN CORNER

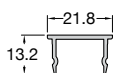

Κωδικός / Code: **FSN-123**

ΒΑΡΟΣ / WEIGHT: 156 gr/m
 ΚΑΠΑΚΙ ΚΟΛΩΝΑΣ FSN-103/104
 COVER FOR COLUMN FSN-103/104

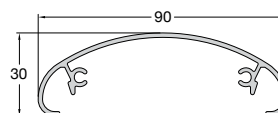

Κωδικός / Code: **FSN-222**

ΒΑΡΟΣ / WEIGHT: 736 gr/m
 ΚΑΠΑΚΙ ΚΟΥΠΑΣΤΗΣ ΟΒΑΛ 90x30
 COVER FOR HANDRAIL OVAL 90x30

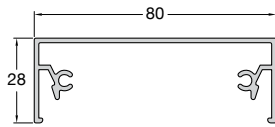

Κωδικός / Code: **FSN-221**

ΒΑΡΟΣ / WEIGHT: 754 gr/m
 ΚΑΠΑΚΙ ΚΟΥΠΑΣΤΗΣ 80x28
 COVER FOR HANDRAIL 80x28

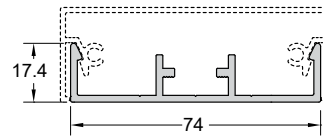

Κωδικός / Code: **CLS-201**

ΒΑΡΟΣ / WEIGHT: 757 gr/m
 ΒΑΣΗ ΚΟΥΠΑΣΤΗΣ FSN-221/222
 BASE FOR HANDRAIL FSN-221/222



Κωδικός / Code: **4289**

ΓΩΝΙΑΚΟΣ ΣΥΝΔΕΣΜΟΣ 90° ΓΙΑ ΚΟΥΠΑΣΤΗ CLS-201
 CORNER CONNECTOR 90° FOR HANDRAIL CLS-201



Κωδικός / Code: **4275**

ΣΥΝΔΕΣΜΟΣ ΚΟΥΠΑΣΤΗΣ
 HANDRAIL CONNECTOR



Κωδικός / Code: **4713**

ΠΕΛΜΑ ΚΟΛΩΝΑΣ FSN-102
 SUPPORT FOOT FOR COLUMN FSN-102



Κωδικός / Code: **4733**

ΠΕΛΜΑ ΚΟΛΩΝΑΣ FSN-102
 SUPPORT FOOT FOR COLUMN FSN-102



Κωδικός / Code: **4716**
 ΓΩΝΙΑΚΟ ΠΕΛΜΑ ΚΟΛΩΝΑΣ FSN-102
 CORNER SUPPORT FOOT FOR COLUMN FSN-102

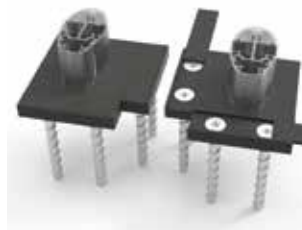

Κωδικός / Code: **4736**
 ΓΩΝΙΑΚΟ ΠΕΛΜΑ ΚΟΛΩΝΑΣ FSN-102
 CORNER SUPPORT FOOT FOR COLUMN FSN-102



Κωδικός / Code: **4738**
 ΠΕΛΜΑ ΚΟΛΩΝΑΣ FSN-102 ΑΡΙΣΤΕΡΟ
 SUPPORT FOOT FOR COLUMN FSN-102 LEFT



Κωδικός / Code: **4739**
 ΠΕΛΜΑ ΚΟΛΩΝΑΣ FSN-102 ΔΕΞΙ
 SUPPORT FOOT FOR COLUMN FSN-102 RIGHT



Κωδικός / Code: **4714**
 ΠΕΛΜΑ ΚΟΛΩΝΑΣ FSN-103
 SUPPORT FOOT FOR COLUMN FSN-103



Κωδικός / Code: **4734**
 ΠΕΛΜΑ ΚΟΛΩΝΑΣ FSN-103
 SUPPORT FOOT FOR COLUMN FSN-103

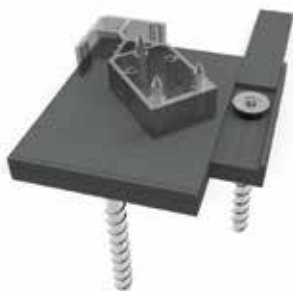

Κωδικός / Code: **4715**
 ΠΕΛΜΑ ΚΟΛΩΝΑΣ FSN-104
 SUPPORT FOOT FOR COLUMN FSN-104

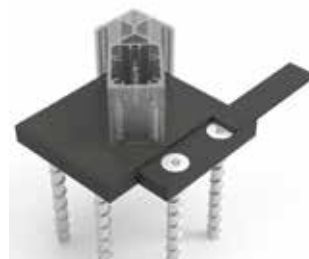

Κωδικός / Code: **4735**
 ΠΕΛΜΑ ΚΟΛΩΝΑΣ FSN-104
 SUPPORT FOOT FOR COLUMN FSN-104



Κωδικός / Code: **4759**
 ΕΞ. ΣΤΗΡΙΓΜΑ ΚΟΛΩΝΑΣ FSN-102 (ΒΑΡΕΩΣ ΤΥΠΟΥ)
 EXT. WALL SUPPORT FOR COLUMN FSN-102 (HEAVY DUTY)



Κωδικός / Code: **4760**
 ΕΞ. ΣΤΗΡΙΓΜΑ ΚΟΛΩΝΑΣ FSN-103 (ΒΑΡΕΩΣ ΤΥΠΟΥ)
 EXT. WALL SUPPORT FOR COLUMN FSN-103 (HEAVY DUTY)



Κωδικός / Code: **4752**
 ΣΤΗΡΙΓΜΑ ΚΟΛΩΝΑΣ FSN-102
 WALL SUPPORT FOR COLUMN FSN-102



Κωδικός / Code: **4756**
 ΣΤΗΡΙΓΜΑ ΚΟΛΩΝΑΣ FSN-102 (ΒΑΡΕΩΣ ΤΥΠΟΥ)
 WALL SUPPORT FOR COLUMN FSN-102 (HEAVY DUTY)



Κωδικός / Code: **4924**
 ΤΑΠΑ ΚΟΛΩΝΑΣ FSN-102
 END CAP FOR COLUMN FSN-102



Κωδικός / Code: **4925**
 ΤΑΠΑ ΚΟΛΩΝΑΣ FSN-102 ΜΒ (ΑΡΙΣΤΕΡΗ)
 END CAP FOR COLUMN FSN-102 (LEFT)



Κωδικός / Code: **4926**
 ΤΑΠΑ ΚΟΛΩΝΑΣ FSN-102 ΜΒ (ΔΕΞΙΑ)
 END CAP FOR COLUMN FSN-102 (RIGHT)



Κωδικός / Code: **4927**
 ΤΑΠΑ ΚΟΛΩΝΑΣ FSN-102 (1)
 END CAP FOR COLUMN FSN-102 (1)



Κωδικός / Code: **4928**
 ΤΑΠΑ ΚΟΛΩΝΑΣ FSN-102 (2)
 END CAP FOR COLUMN FSN-102 (2)



Κωδικός / Code: **4929**
 ΤΑΠΑ ΚΟΛΩΝΑΣ FSN-102 (3)
 END CAP FOR COLUMN FSN-102 (3)



Κωδικός / Code: **4936**

ΤΑΠΑ ΚΟΛΩΝΑΣ FSN-102 (ΑΡΙΣΤΕΡΗ)
END CAP FOR COLUMN FSN-102 (LEFT)



Κωδικός / Code: **4937**

ΤΑΠΑ ΚΟΛΩΝΑΣ FSN-102 MB (ΔΕΞΙΑ)
END CAP FOR COLUMN FSN-102 (RIGHT)



Κωδικός / Code: **4930**

ΤΑΠΑ ΚΟΛΩΝΑΣ FSN-103
END CAP FOR COLUMN FSN-103



Κωδικός / Code: **4931**

ΤΑΠΑ ΚΟΛΩΝΑΣ FSN-103 (ΑΡΙΣΤΕΡΗ)
END CAP FOR COLUMN FSN-103 (LEFT)

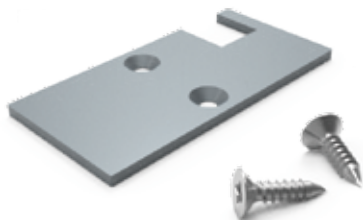

Κωδικός / Code: **4932**

ΤΑΠΑ ΚΟΛΩΝΑΣ FSN-103 (ΔΕΞΙΑ)
END CAP FOR COLUMN FSN-103 (RIGHT)



Κωδικός / Code: **4933**

ΤΑΠΑ ΚΟΛΩΝΑΣ FSN-103 (2)
END CAP FOR COLUMN FSN-103 (2)



Κωδικός / Code: **4934**

ΤΑΠΑ ΚΟΛΩΝΑΣ FSN-104
END CAP FOR COLUMN FSN-104



Κωδικός / Code: **4935**

ΤΑΠΑ ΚΟΛΩΝΑΣ FSN-104 (2)
END CAP FOR COLUMN FSN-104 (2)



Κωδικός / Code: **4947**

ΓΩΝΙΑΚΗ ΤΑΠΑ ΚΟΛΩΝΑΣ FSN-102
END CORNER CAP FOR COLUMN FSN-102



Κωδικός / Code: **4948**

ΤΑΠΑ ΚΟΛΩΝΑΣ FSN-103
END CORNER CAP FOR COLUMN FSN-103



Κωδικός / Code: **4921**

ΤΑΠΑ ΚΟΥΠΑΣΤΗΣ FSN-222
END CAP FOR HANDRAIL FSN-222



Κωδικός / Code: **4270**

ΣΥΝΔΕΣΜΟΣ CLS-201/301/302/305
CONNECTOR FOR CLS-201/301/302/305



Κωδικός / Code: **4913**

ΥΠΟΣΤΗΡΙΓΜΑ ΤΖΑΜΙΟΥ ORBIT 1/2
GLASS SUPPORT ORBIT 1/2



Κωδικός / Code: **US530-2/3/4 PRM**

ΛΑΣΤΙΧΟ ΣΦΗΝΑ
GLAZING GASKET

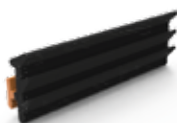

Κωδικός / Code: **4912**

ΛΑΣΤΙΧΟ ΣΦΗΝΑ ΟΔΗΓΟΥ F50-319 ΓΙΑ ΤΖΑΜΙ 10mm
GASKET FOR F50-319 RAIL 10mm GLASS



Κωδικός / Code: **US530-1 PRM**

ΛΑΣΤΙΧΟ ΣΦΗΝΑ 1 MM
GLAZING GASKET

Elxis



Elxis Assembly



RAIL ASSEMBLY TYPICAL STEPS:

1. ASSEMBLE POST & FOOTPLATE
2. FIX ASSEMBLED POST ONTO THE GROUND
3. SCREW GLASS HOLDER (DETAIL F) ONTO POST ON THE UPPER PART & LOWER PART OF THE POST
4. MOUNT ASSEMBLED GLASS PANEL ONTO POST GLASS HOLDER
5. SCREW FIX RECTANGULAR HANDRAIL ONTO POST, TO CONNECT POSTS IN THE LINE
6. FINALLY, CLICK & CONNECT THE TOP HANDRAIL PART ONTO THE RECTANGULAR HANDRAIL TO FULLFILL THE RAIL ASSEMBLY

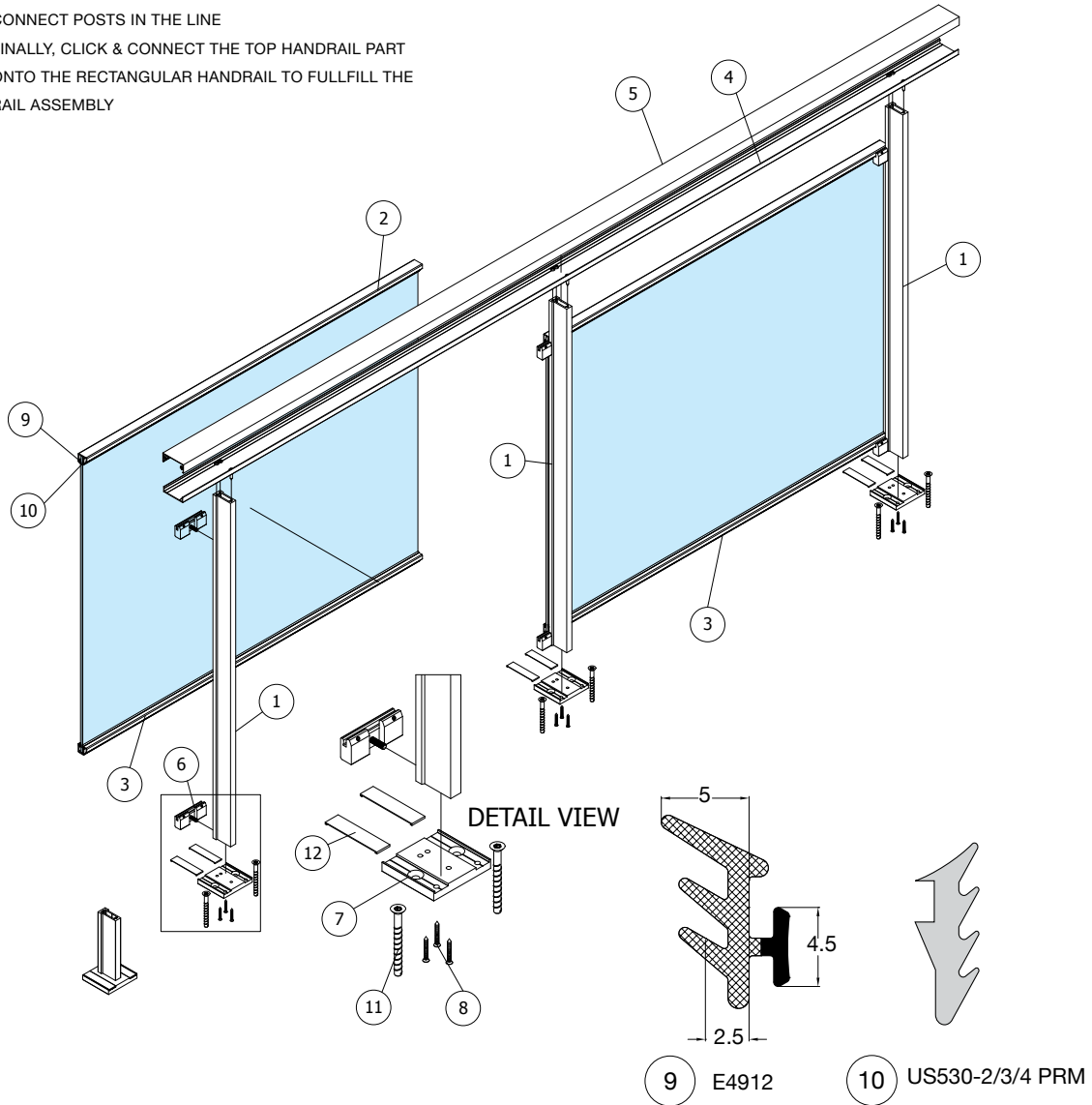

ΛΙΣΤΑ ΥΛΙΚΩΝ / PARTS LIST			
TEM ITEM	ΠΟΣ QTY	ΚΩΔΙΚΟΣ PART NUMBER	ΠΕΡΙΓΡΑΦΗ / DESCRIPTION
1	3	FSN-101	ΚΟΛΩΝΑ ELXIS / ELXIS POST
2	2	FSN-301	ΑΝΩ ΟΔΗΓΟΣ ΤΖΑΜΙΟΥ / GLASS GUIDE RAIL
3	2	FSN-300	ΚΑΤΩ ΟΔΗΓΟΣ ΤΖΑΜΙΟΥ / GLASS GUIDE RAIL
4	1	CLS-201	ΒΑΣΗ ΚΟΥΠΙΑΣΤΗΣ / HANDRAIL BASE
5	1	FSN-221	ΚΑΠΑΚΙ ΚΟΥΠΙΑΣΤΗΣ / HANDRAIL COVER
6	6	4753	ΣΥΓΚΡΑΤΗΡΑΣ ΥΑΛΟΠΙΝΑΚΑ GLASS HOLDER
7	3	4711	ΠΕΛΑΜΑ ELXIS / ELXIS FOOTPLATE
8	9	DIN7982-6.3x50	ΒΙΔΕΣ ΠΕΛΑΜΑΤΟΣ / FOOTPLATE SCREWS
9	2	E4912	ΛΑΣΤΙΧΟ / GASKET
10	2	US530-2/3/4 PRM	ΛΑΣΤΙΧΟ ΣΦΗΝΑ / GLAZING GASKET
11	2	EBM-10120G/2	ΜΠΕΤΟΒΙΔΑ / FISCHER CONCRETE SCREW
12	2	E4710	ΚΑΠΑΚΙ ΠΕΛΑΜΑΤΟΣ / FOOTPLATE COVER

STEP 1

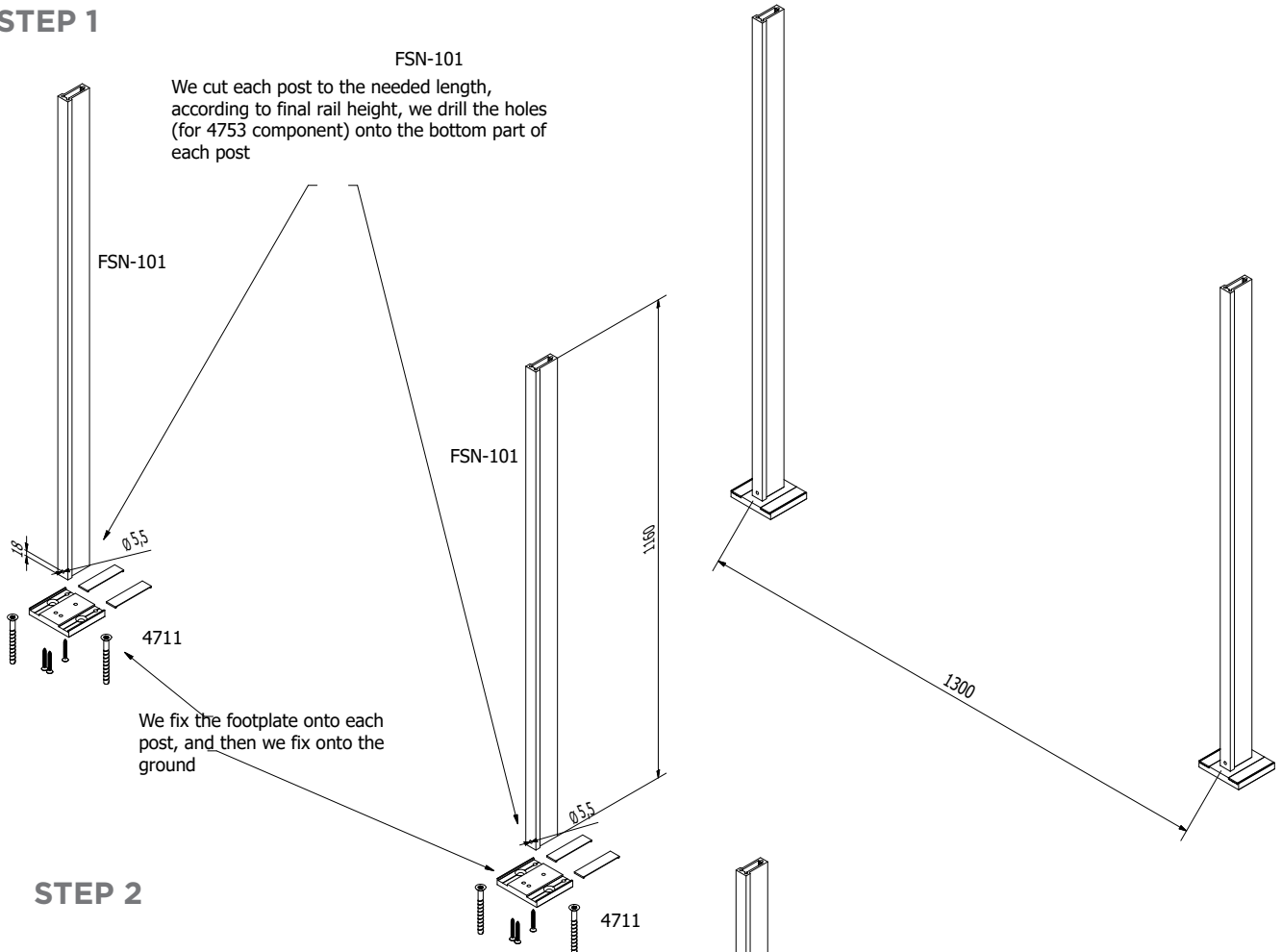

STEP 2

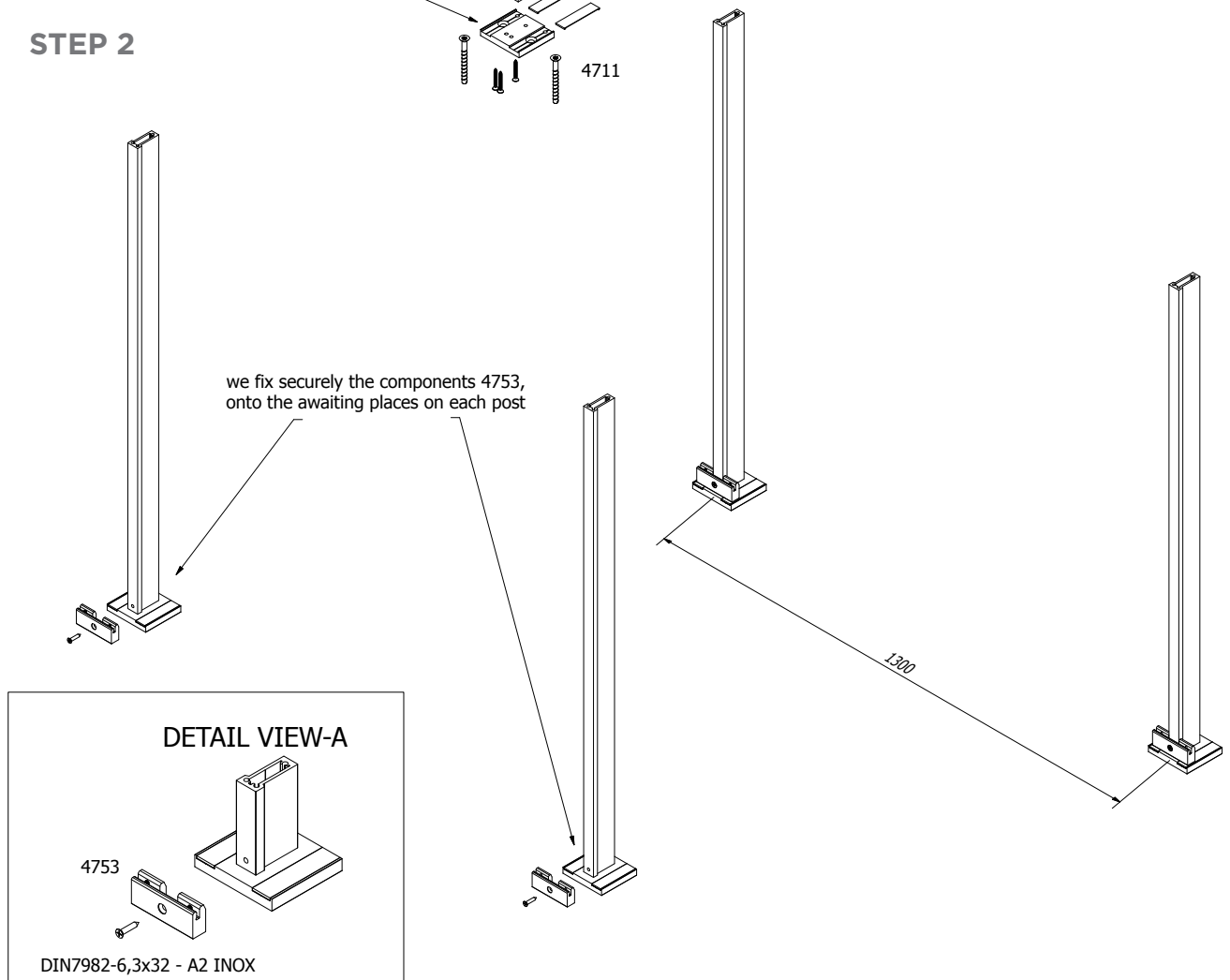

STEP 3

We mount the Glass Guide FSN-300 onto the posts, and then we screw firmly with set screw **DIN 913-M6x12 - A2 INOX** onto **FSN300**

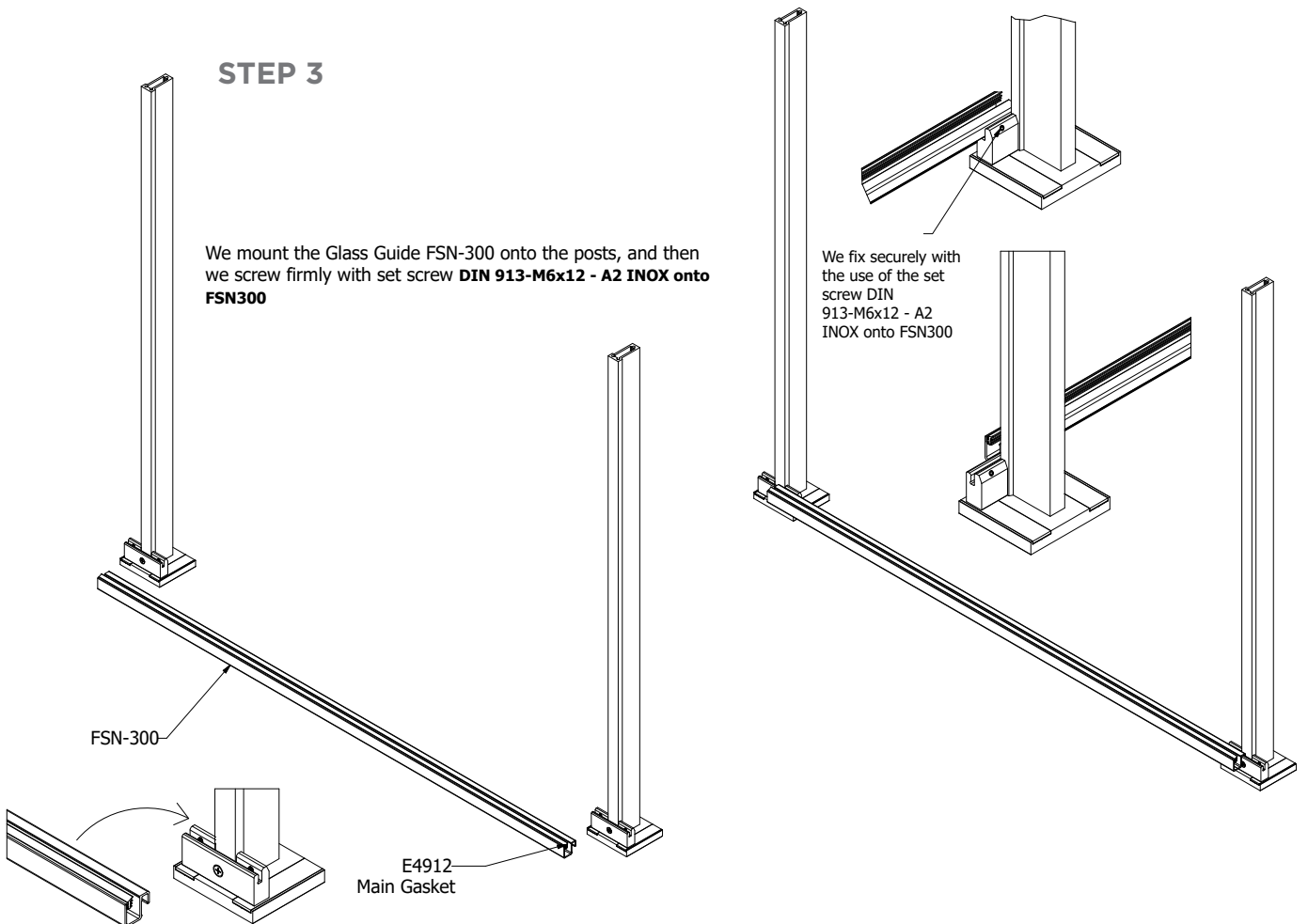

STEP 4

We predrill FSN-203, according to respective post distance, so as to fix it onto the two posts FSN 101

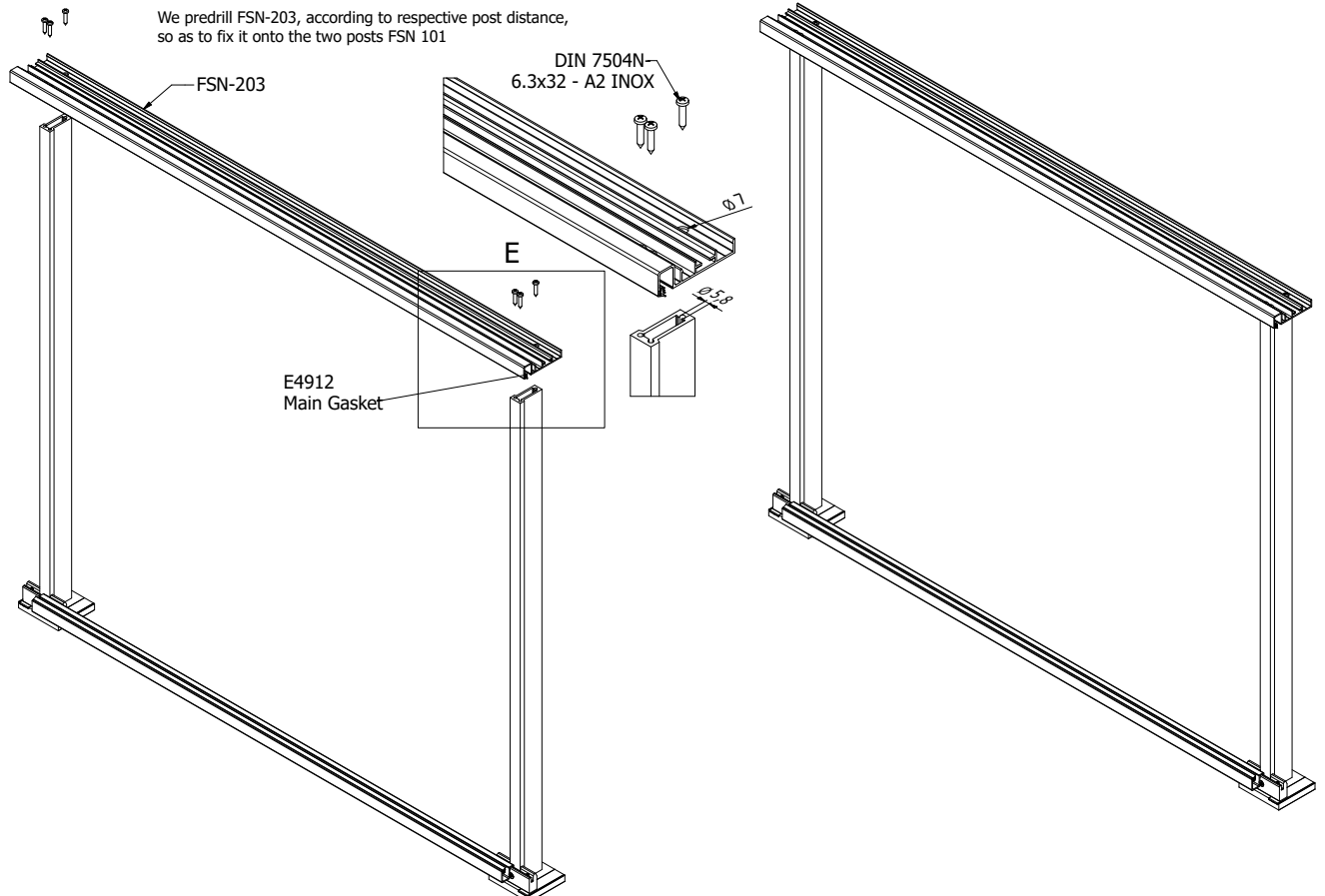

STEP 5

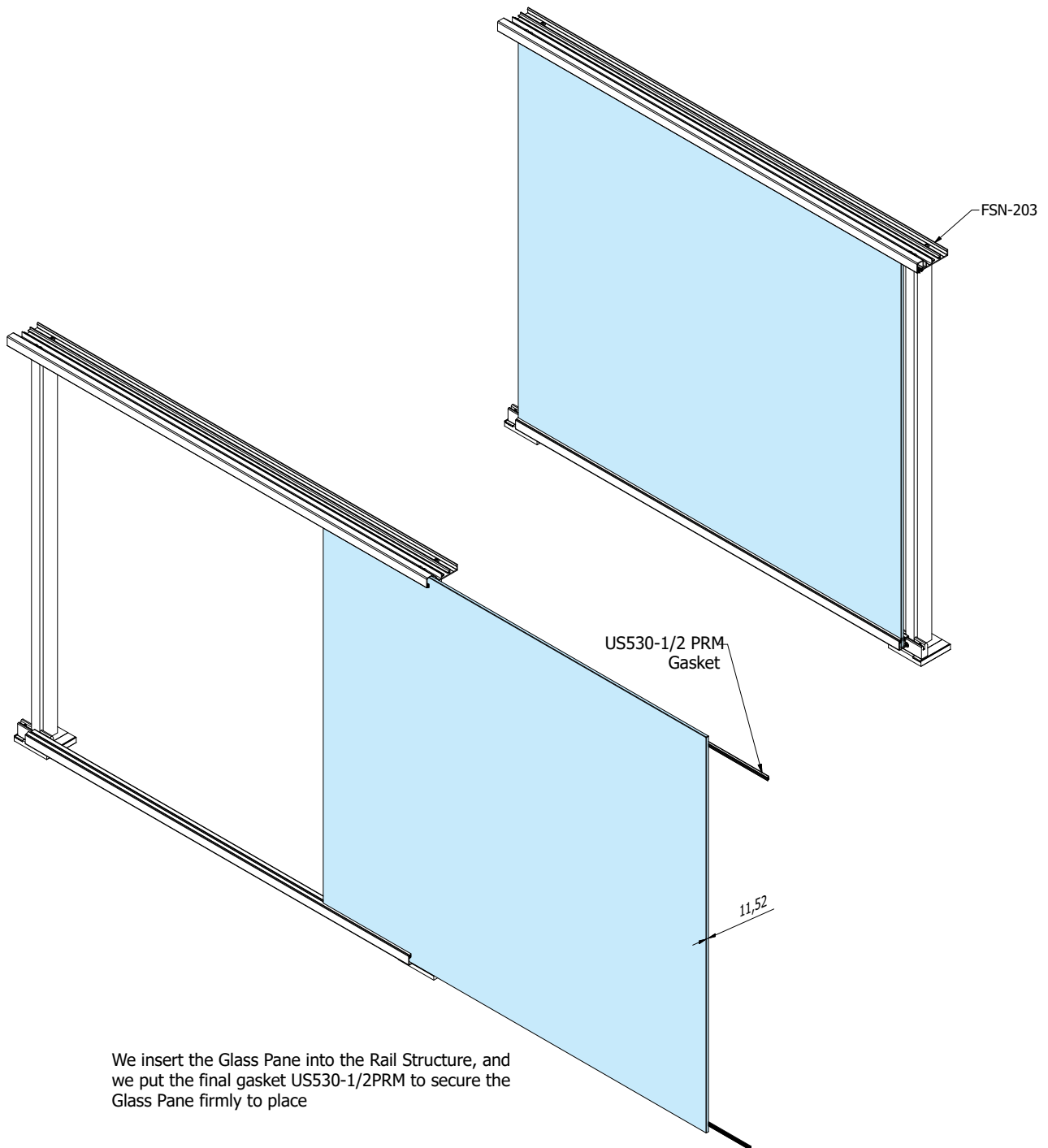

We insert the Glass Pane into the Rail Structure, and we put the final gasket US530-1/2PRM to secure the Glass Pane firmly to place

STEP 6

Finally, we clip the FSN-223 top part onto the FSN-203 bottom handrail part

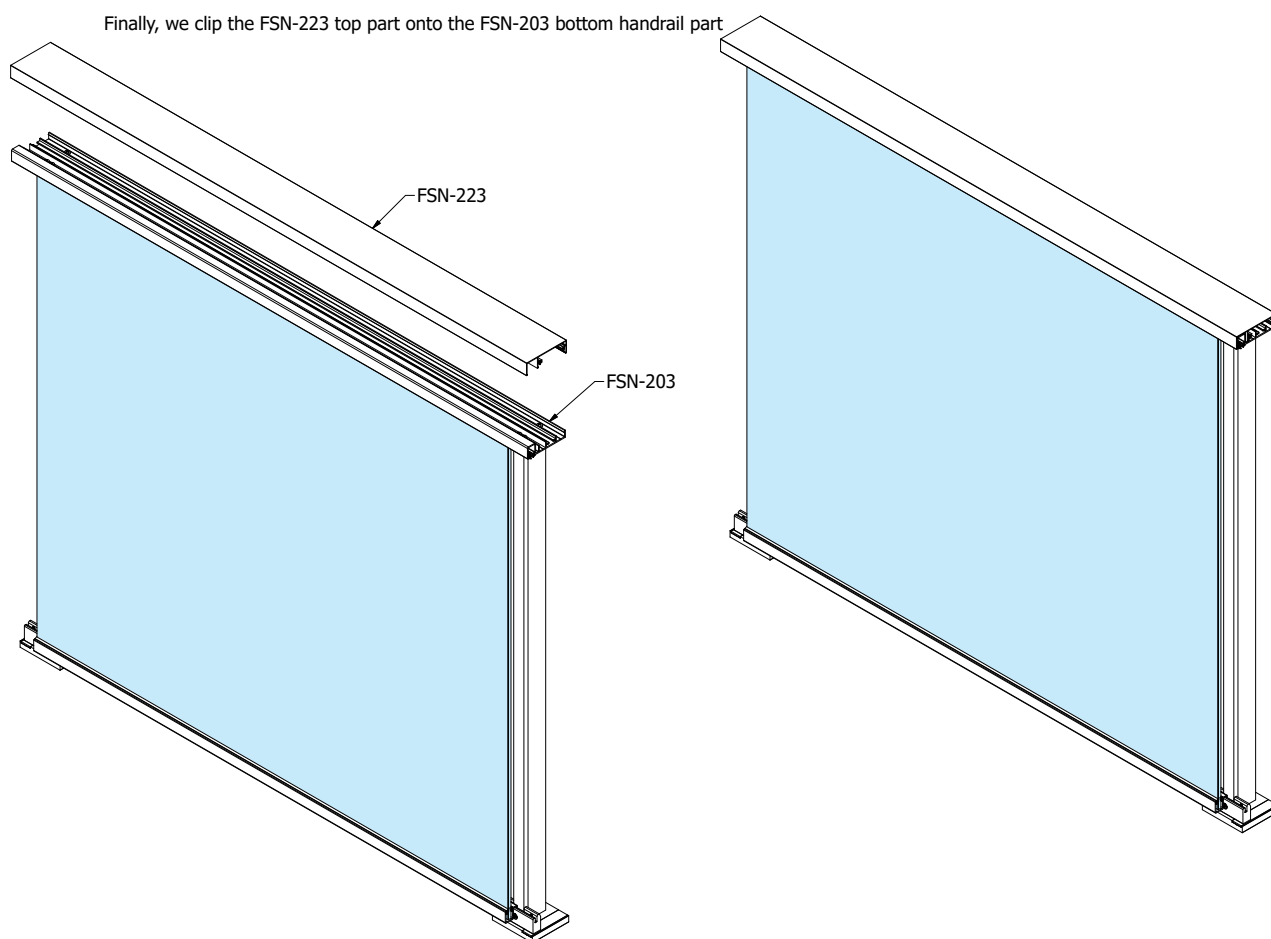

Elxis Profiles & Accessories



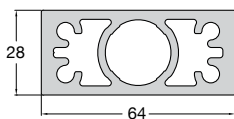

Κωδικός / Code: **FSN-105**

ΒΑΡΟΣ / WEIGHT: 2354 gr/m

ΚΟΛΩΝΑ 28x64

COLUMN 28x64

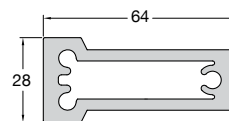

Κωδικός / Code: **FSN-101**

ΒΑΡΟΣ / WEIGHT: 1980 gr/m

ΚΟΛΩΝΑ 28x64

COLUMN 28x64

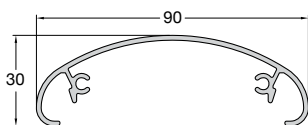

Κωδικός / Code: **FSN-222**

ΒΑΡΟΣ / WEIGHT: 736 gr/m

ΚΑΠΑΚΙ ΟΒΑΛ ΚΟΥΠΑΣΤΗΣ 90X30

COVER FOR HANDRAIL 90X30

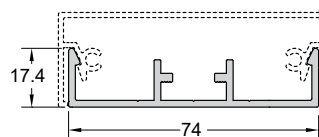

Κωδικός / Code: **CLS-201**

ΒΑΡΟΣ / WEIGHT: 757 gr/m

ΒΑΣΗ ΚΟΥΠΑΣΤΗΣ FSN-221/222

BASE FOR HANDRAIL FSN-221/222

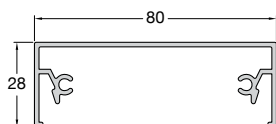

Κωδικός / Code: **FSN-221**

ΒΑΡΟΣ / WEIGHT: 754 gr/m

ΚΑΠΑΚΙ ΚΟΥΠΑΣΤΗΣ 80X28

COVER FOR HANDRAIL 80X28

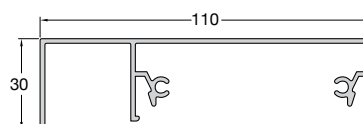

Κωδικός / Code: **FSN-223**

ΒΑΡΟΣ / WEIGHT: 1006 gr/m

ΚΑΠΑΚΙ ΚΟΥΠΑΣΤΗΣ 110x30

COVER FOR HANDRAIL 110x30

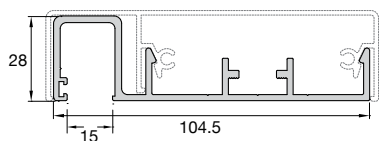

Κωδικός / Code: **FSN-203**

ΒΑΡΟΣ / WEIGHT: 1260 gr/m
 ΒΑΣΗ ΚΟΥΠΑΣΤΗΣ FSN-223
 BASE FOR HANDRAIL FSN-223

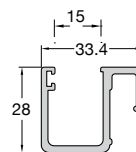

Κωδικός / Code: **FSN-300**

ΒΑΡΟΣ / WEIGHT: 607 gr/m
 ΟΔΗΓΟΣ ΚΑΤΩ ΤΖΑΜΙΟΥ
 GUIDE FOR GLASS (DOWN)

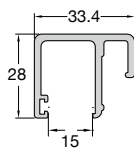

Κωδικός / Code: **FSN-301**

ΒΑΡΟΣ / WEIGHT: 607 gr/m
 ΟΔΗΓΟΣ ΑΝΩ ΤΖΑΜΙΟΥ
 GUIDE FOR GLASS (UP)



Κωδικός / Code: **4167**

ΕΝΔΟΔΑΠΕΔΙΟ ΣΤΗΡΙΓΜΑ ΓΙΑ ΚΟΛΩΝΑ FSN-105
 INFLOOR SUPPORT FOR COLUMN FSN-105



Κωδικός / Code: **4289**

ΓΩΝΙΑΚΟΣ ΣΥΝΔΕΣΜΟΣ 90° ΓΙΑ ΚΟΥΠΑΣΤΗ CLS-201
 CORNER CONNECTOR 90° FOR HANDRAIL CLS-201



Κωδικός / Code: **4275**

ΣΥΝΔΕΣΜΟΣ ΚΟΥΠΑΣΤΗΣ
 HANDRAIL CONNECTOR



Κωδικός / Code: **4711**

ΠΕΛΜΑ ΚΟΛΩΝΑΣ FSN-101
 SUPPORT FOOT FOR COLUMN FSN-101



Κωδικός / Code: **4731**
 ΠΕΛΜΑ ΚΟΛΩΝΑΣ FSN-105
 SUPPORT FOOT FOR COLUMN FSN-105



Κωδικός / Code: **4717**
 ΠΕΛΜΑ ΚΟΛΩΝΑΣ FSN-105
 SUPPORT FOOT FOR COLUMN FSN-105

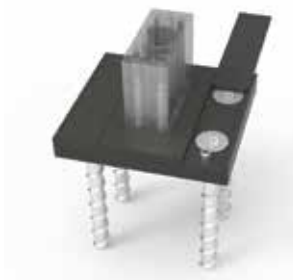

Κωδικός / Code: **4737**
 ΠΕΛΜΑ ΚΟΛΩΝΑΣ FSN-105
 SUPPORT FOOT FOR COLUMN FSN-105



Κωδικός / Code: **4923**
 ΤΑΠΑ ΚΟΥΠΑΣΤΗΣ FSN-223
 END CAP FOR HANDRAIL FSN-223



Κωδικός / Code: **US530-2/3/4 PRM**
 ΛΑΣΤΙΧΟ ΣΦΗΝΑ
 GLAZING GASKET

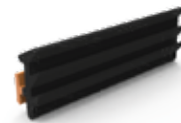

Κωδικός / Code: **4912**
 ΛΑΣΤΙΧΟ ΣΦΗΝΑ
 GLAZING GASKET



Κωδικός / Code: **4938**
 ΤΑΠΑ ΚΟΛΩΝΑΣ FSN-101
 END CAP FOR COLUMN FSN-101



Κωδικός / Code: **EA410-420M**
 ΛΑΣΤΙΧΟ ΣΦΗΝΑ 1 MM
 GLAZING GASKET



Κωδικός / Code: **4751**
 ΣΤΗΡΙΓΜΑ ΚΟΛΩΝΑΣ FSN-101
 WALL SUPPORT FOR COLUMN FSN-101



Κωδικός / Code: **4755**
 ΣΤΗΡΙΓΜΑ ΚΟΛΩΝΑΣ FSN-101 (ΒΑΡΕΩΣ ΤΥΠΟΥ)
 WALL SUPPORT FOR COLUMN FSN-101 (HEAVY DUTY)



Κωδικός / Code: **4753 / 4758**
 ΣΤΗΡΙΓΜΑ ΤΖΑΜΙΟΥ ΚΟΛΩΝΑΣ FSN-101
 GLASS SUPPORT FOR COLUMN FSN-101



Κωδικός / Code: **4270**
 ΣΥΝΔΕΣΜΟΣ CLS-201/301/302/305
 CONNECTOR FOR CLS-201/301/302/305



Κωδικός / Code: **4921**
 ΤΑΠΑ ΚΟΥΠΑΣΤΗΣ FSN-222
 END CAP FOR HANDRAIL FSN-222



Κωδικός / Code: **4922**
 ΤΑΠΑ ΚΟΥΠΑΣΤΗΣ FSN-221
 END CAP FOR HANDRAIL FSN-221

Synthesis



Synthesis Assembly



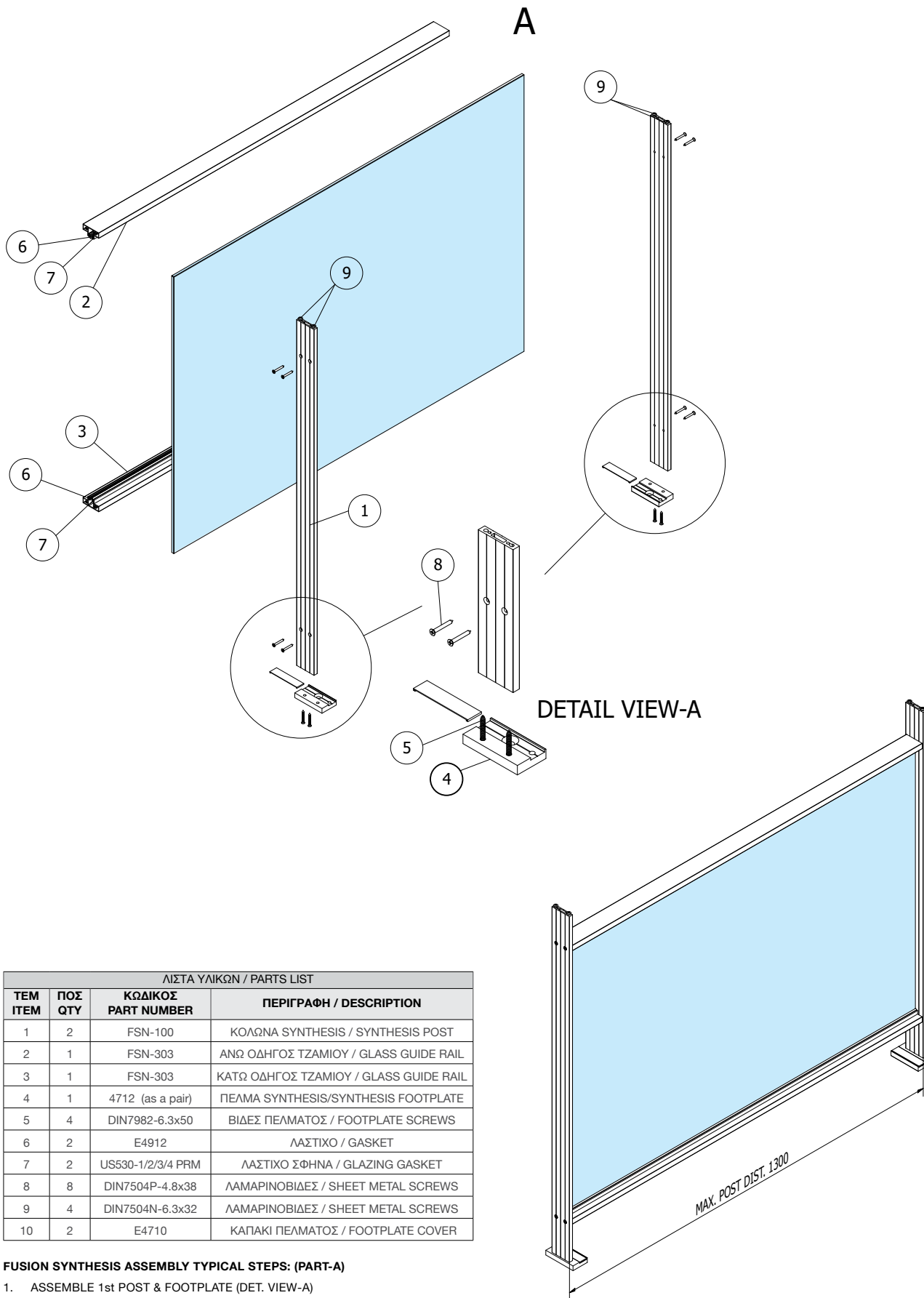

ΛΙΣΤΑ ΥΛΙΚΩΝ / PARTS LIST			
TEM ITEM	ΠΟΣ QTY	ΚΩΔΙΚΟΣ PART NUMBER	ΠΕΡΙΓΡΑΦΗ / DESCRIPTION
1	2	FSN-100	ΚΟΛΩΝΑ SYNTHESIS / SYNTHESIS POST
2	1	FSN-303	ΑΝΩ ΟΔΗΓΟΣ ΤΖΑΜΙΟΥ / GLASS GUIDE RAIL
3	1	FSN-303	ΚΑΤΩ ΟΔΗΓΟΣ ΤΖΑΜΙΟΥ / GLASS GUIDE RAIL
4	1	4712 (as a pair)	ΠΕΛΜΑ SYNTHESIS/SYNTHESIS FOOTPLATE
5	4	DIN7982-6.3x50	ΒΙΔΕΣ ΠΕΛΜΑΤΟΣ / FOOTPLATE SCREWS
6	2	E4912	ΛΑΣΤΙΧΟ / GASKET
7	2	US530-1/2/3/4 PRM	ΛΑΣΤΙΧΟ ΣΦΗΝΑ / GLAZING GASKET
8	8	DIN7504P-4.8x38	ΛΑΜΑΡΙΝΟΒΙΔΕΣ / SHEET METAL SCREWS
9	4	DIN7504N-6.3x32	ΛΑΜΑΡΙΝΟΒΙΔΕΣ / SHEET METAL SCREWS
10	2	E4710	ΚΑΠΑΚΙ ΠΕΛΜΑΤΟΣ / FOOTPLATE COVER

FUSION SYNTHESIS ASSEMBLY TYPICAL STEPS: (PART-A)

1. ASSEMBLE 1st POST & FOOTPLATE (DET. VIEW-A)
2. SCREW FSN-303 ONTO THE LOWER PART OF THE POST
3. SCREW FSN-303, ONTO THE UPPER PART OF THE POST
4. INSERT GASKETS & GLASS INTO FSN-303 PROFILES
5. ASSEMBLE 2nd POST & FOOTPLATE (DET. VIEW-A), AND SCREW IT ONTO AWAITING ASSEMBLY TO FORM TOTAL STRUCTURE OF ONE GLASS PANE
6. PUT TOTAL ASSEMBLED RAIL TYPE PANEL ONTO THE GROUND

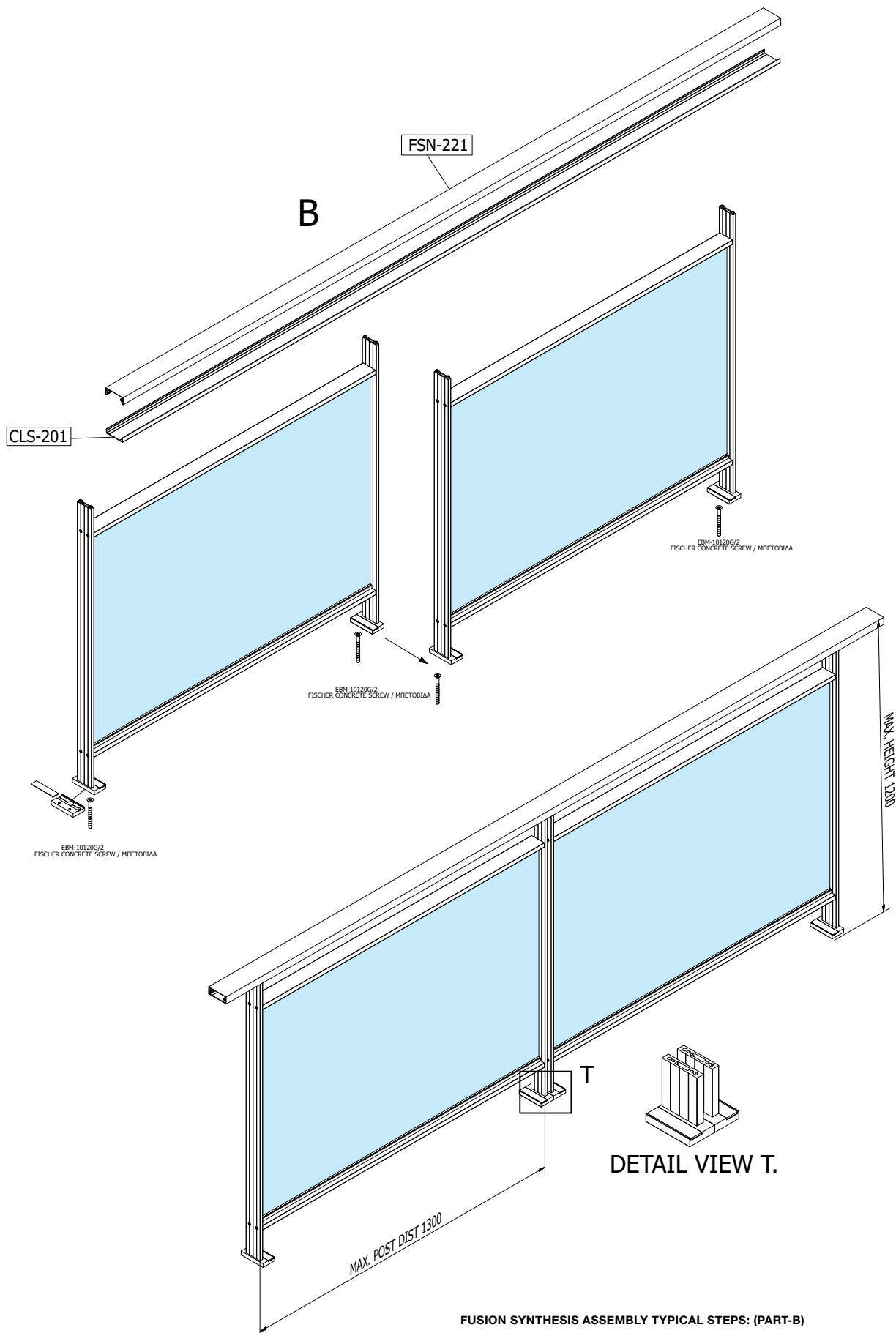

ΛΙΣΤΑ ΥΛΙΚΩΝ / PARTS LIST

TEM ITEM	ΠΟΣ QTY	ΚΩΔΙΚΟΣ PART NUMBER	ΠΕΡΙΓΡΑΦΗ / DESCRIPTION
1	1	CLS-201	ΒΑΣΗ ΚΟΥΠΙΑΣΤΗΣ / HANDRAIL BASE
2	1	FSN-221	ΚΑΠΑΚΙ ΚΟΥΠΙΑΣΤΗΣ / HANDRAIL COVER

FUSION SYNTHESIS ASSEMBLY TYPICAL STEPS: (PART-B)

7. FIX TWO ASSEMBLED RAIL PANELS CLOSE TO EACH OTHER ONTO THE GROUND (DET. VIEW- T), WITH FISCHER CONCRETE SCREW
8. SCREW HANDRAIL BOTTOM PART ON THE TOP PART OF THE POSTS
9. CLICK AND CONNECT HANDRAIL UPPER PART ONTO THE HANDRAIL BOTTOM PART TO COMPLETE THE RAIL TYPE ASSEMBLY

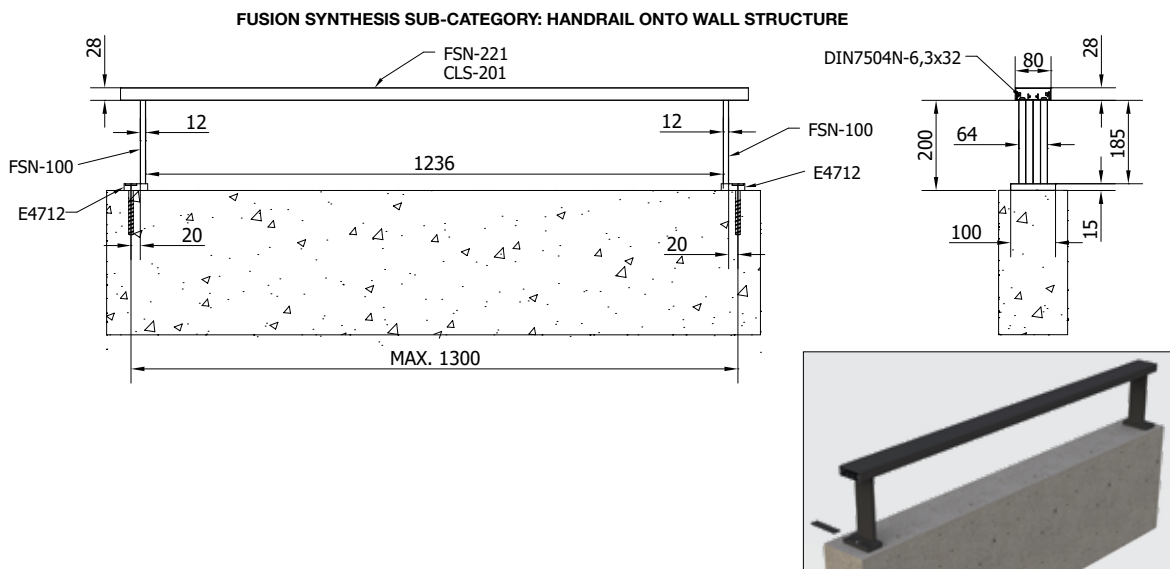
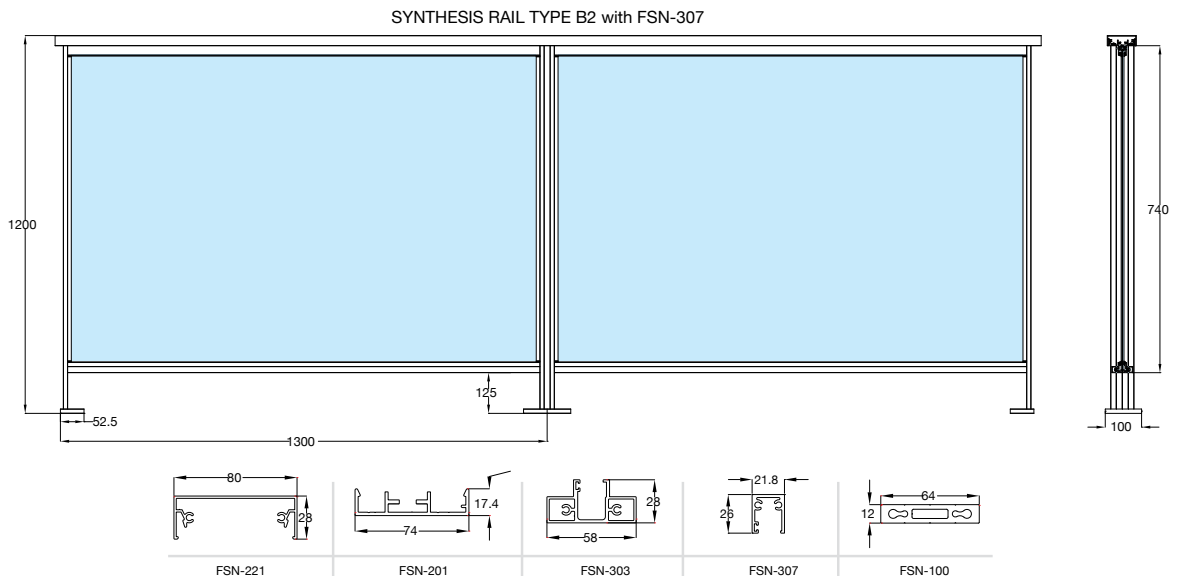
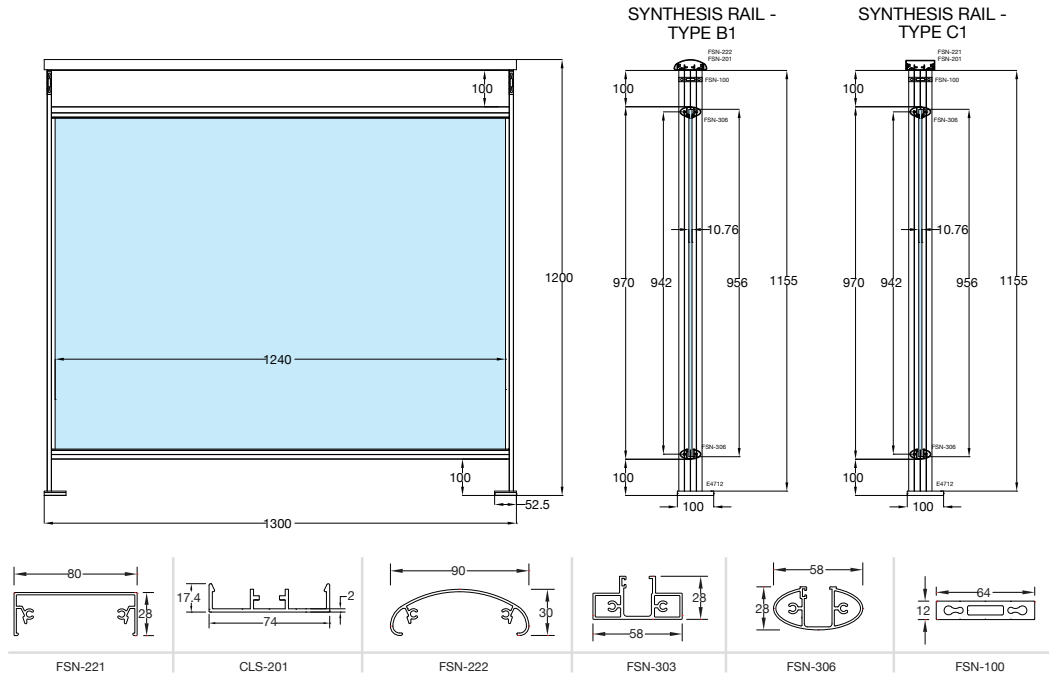

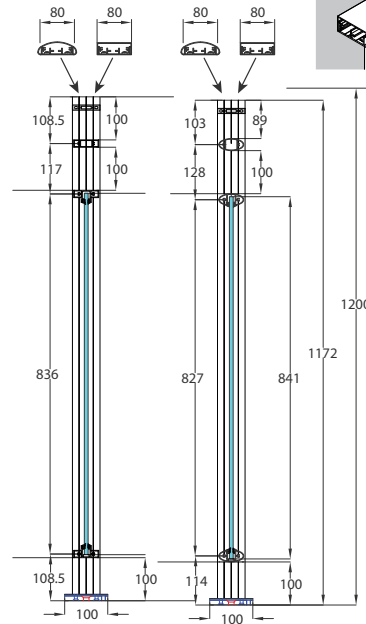
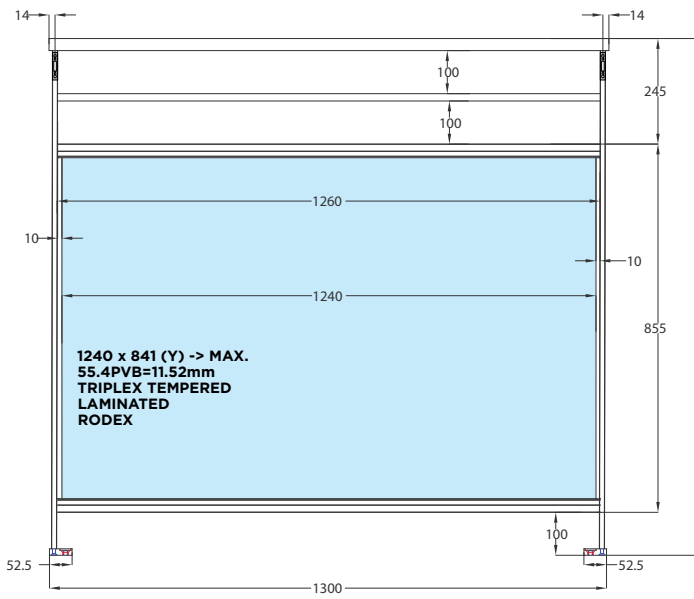

TYPE B3



TYPE C3

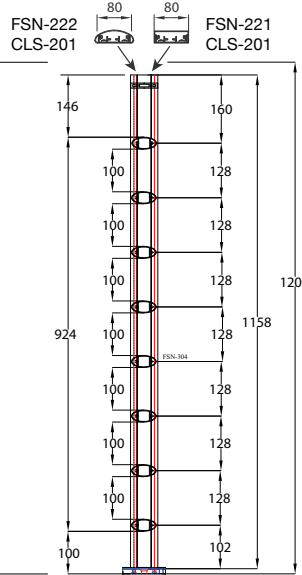
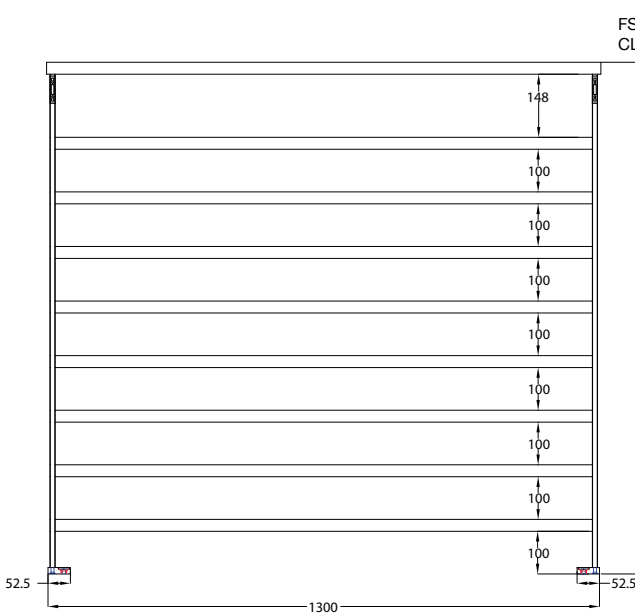
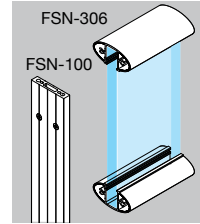
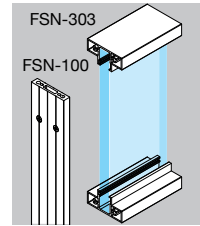

TYPE B4



TYPE C4

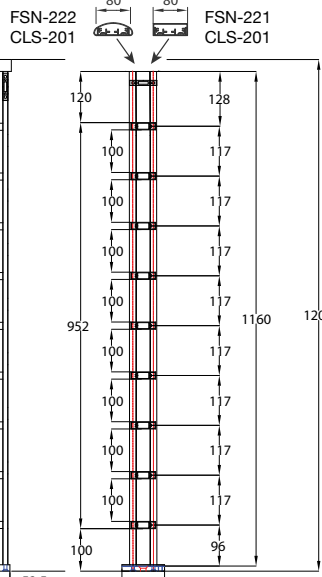
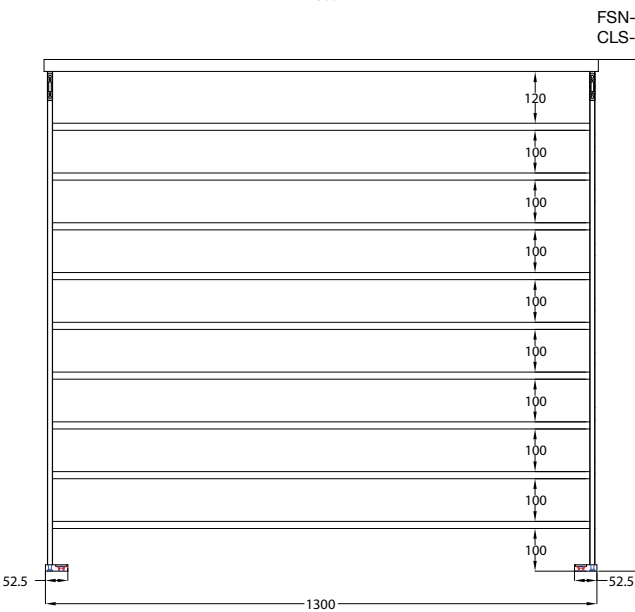
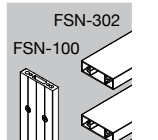
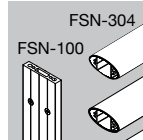

TYPE B4



TYPE C4

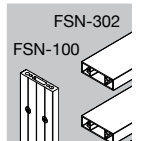
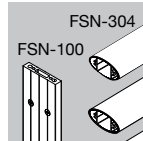
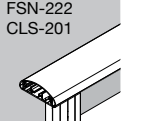

STEP 1

We cut the post FSN-100 to the needed length, we predrill the holes for mounting of the FSN-302 inner rails, and fix securely the footplate 4702 onto the awaiting post, and then fix the post to the ground.

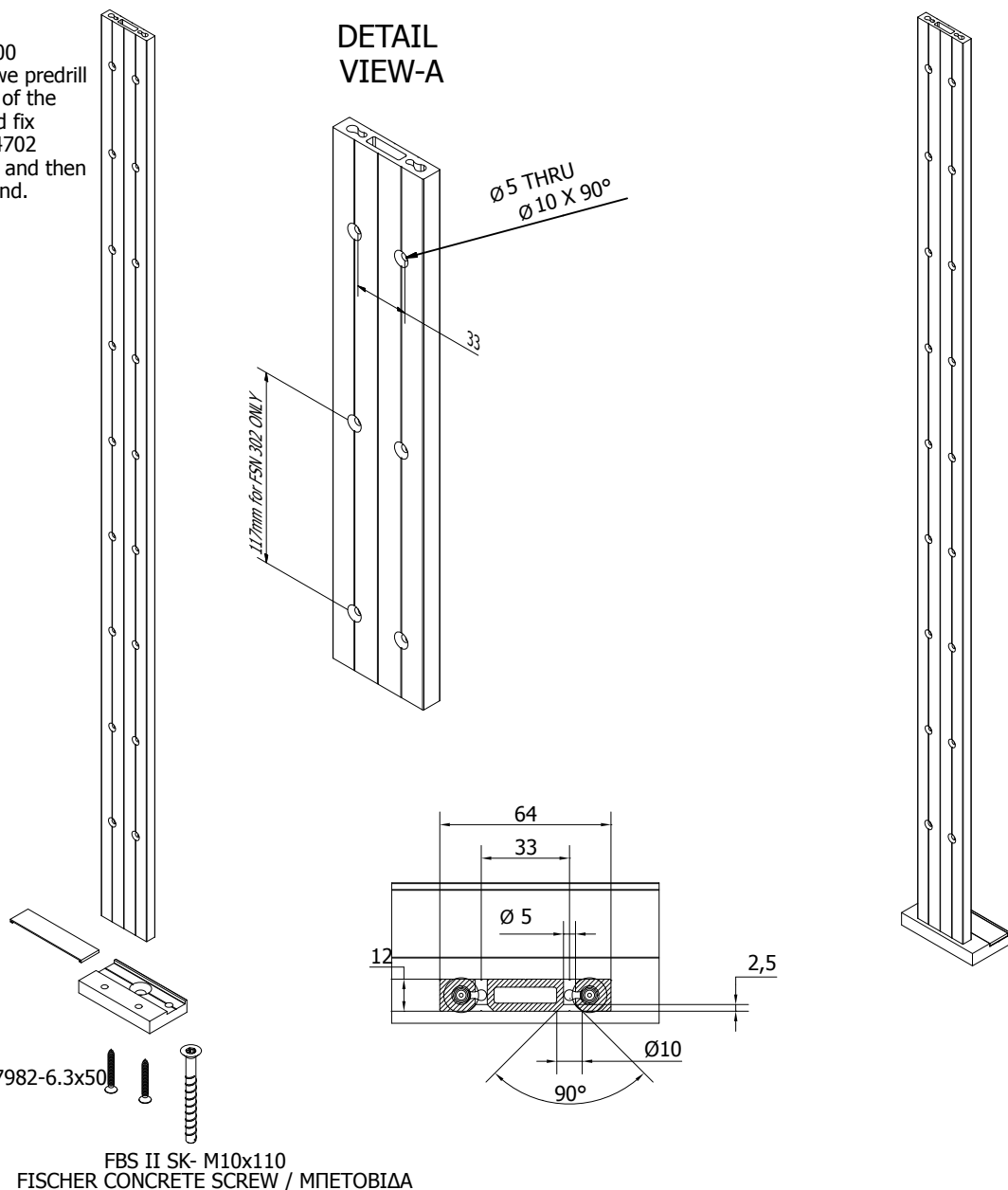

STEP 2

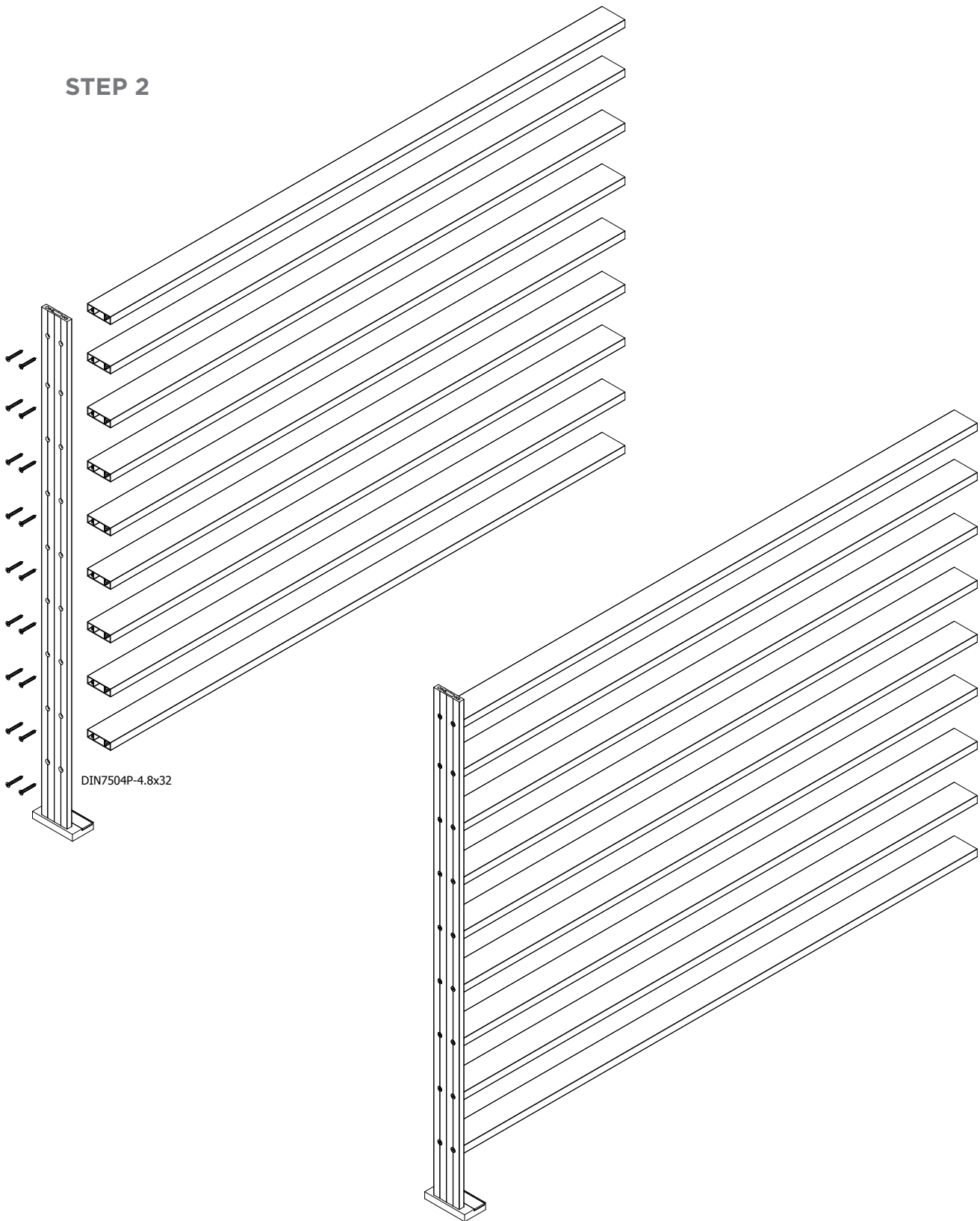

We screw the inner rails FSN-302 onto the post FSN-100.

STEP 3

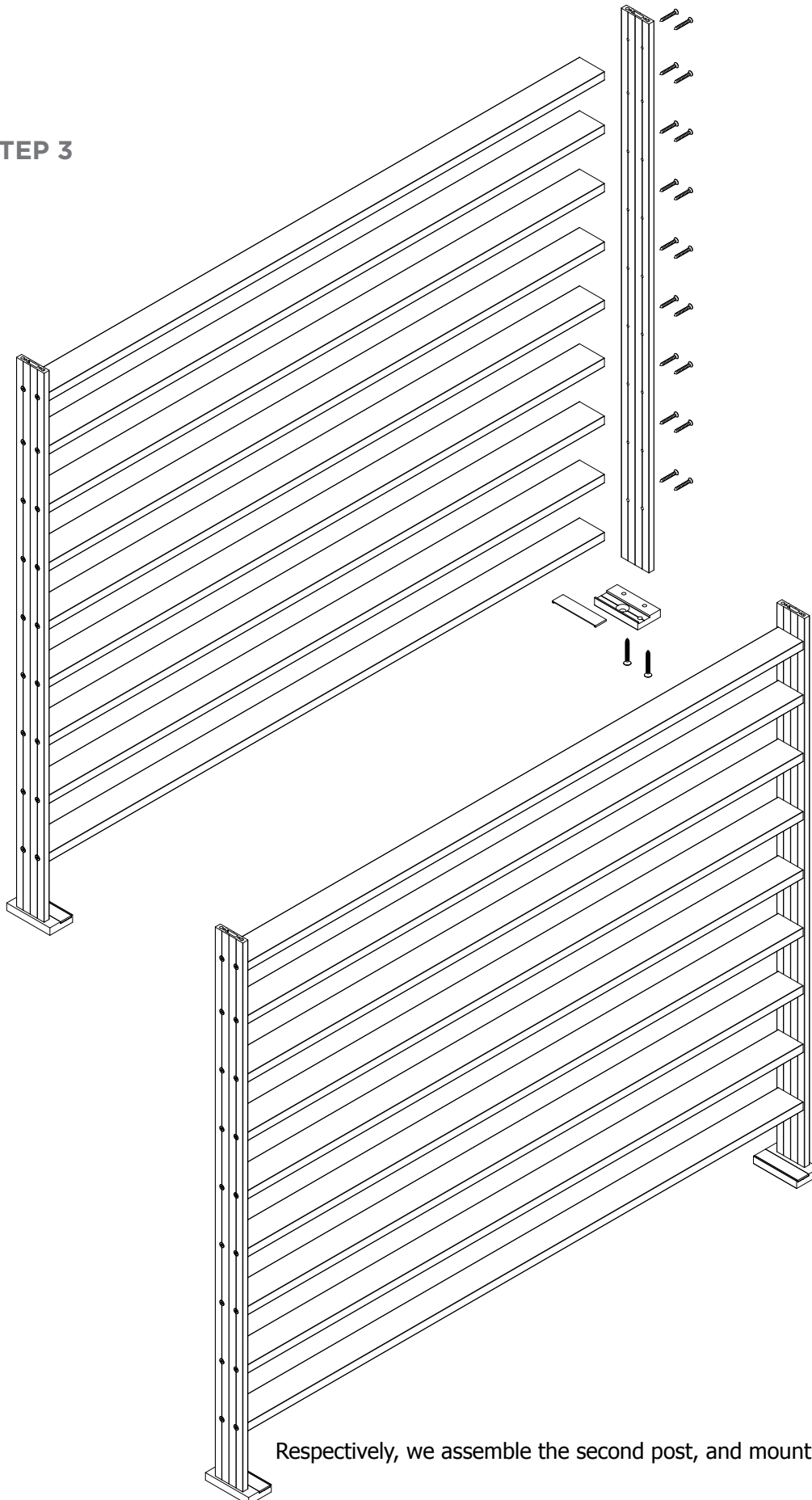

Respectively, we assemble the second post, and mount it onto the rail.

We predrill the bottom handrail part CLS-201, and then we mount it onto the awaiting rail, and we screw firmly onto the two posts, to the given positions.

STEP 4

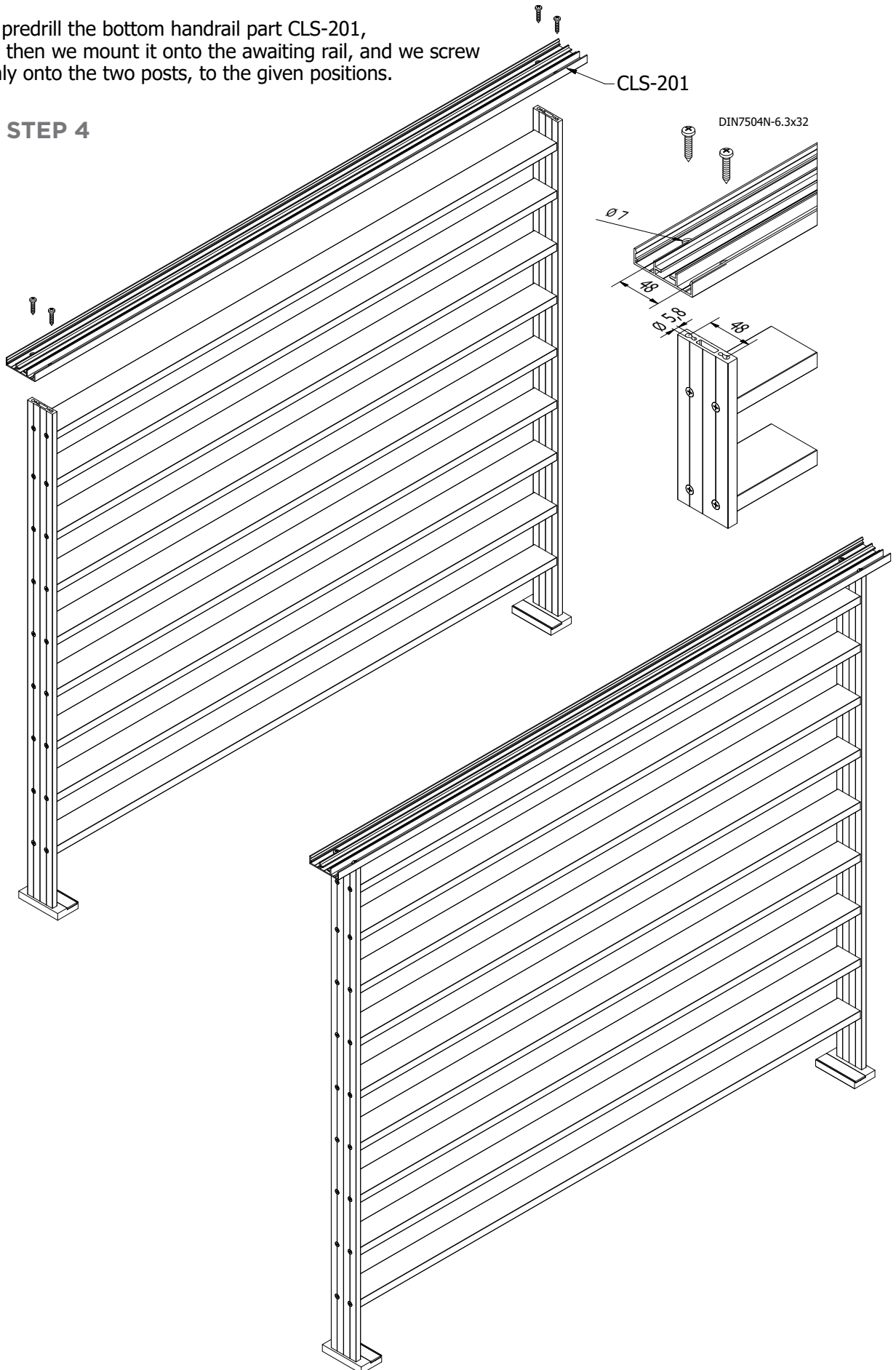

STEP 5

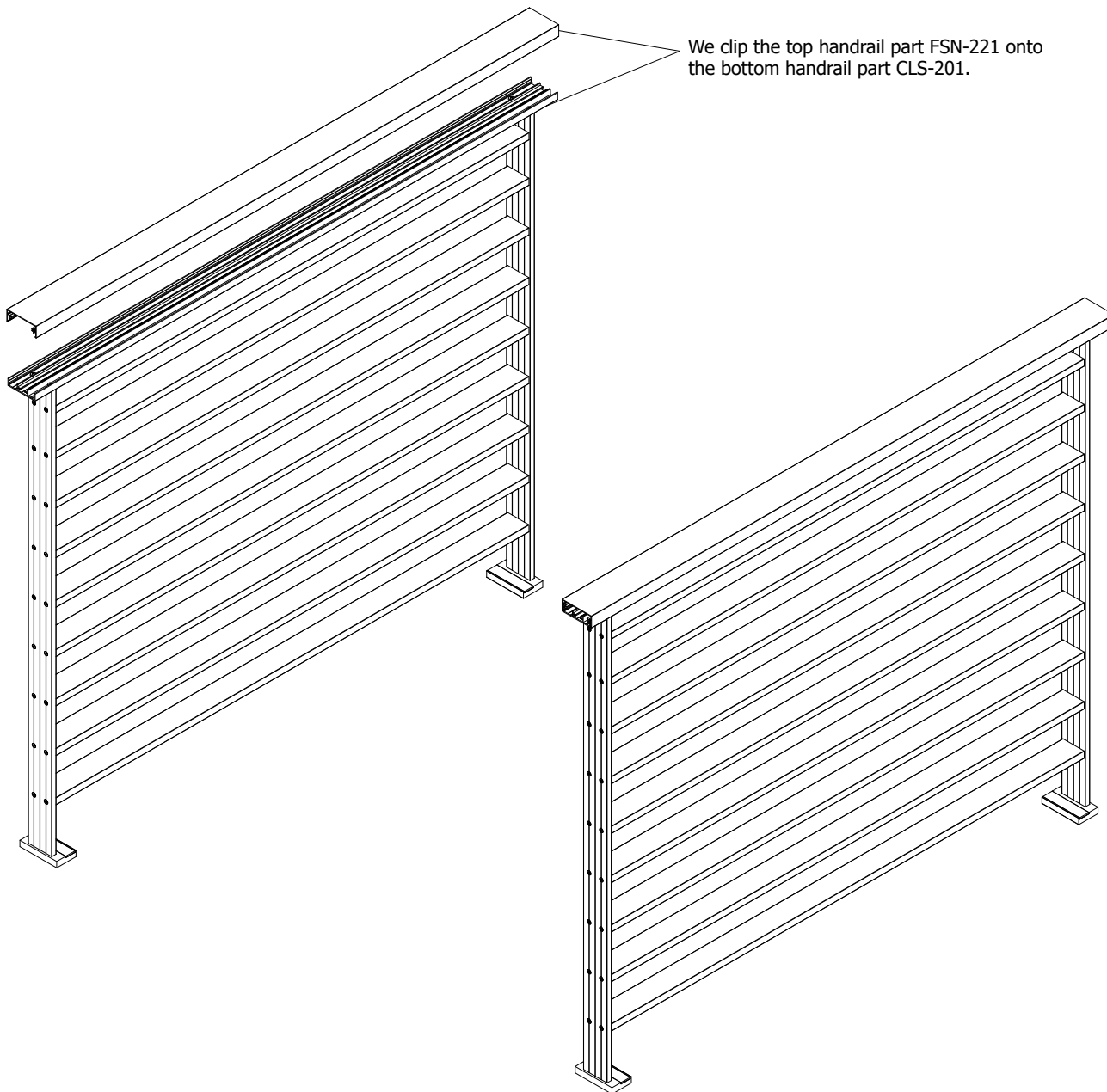

Synthesis

Ground fixing guide



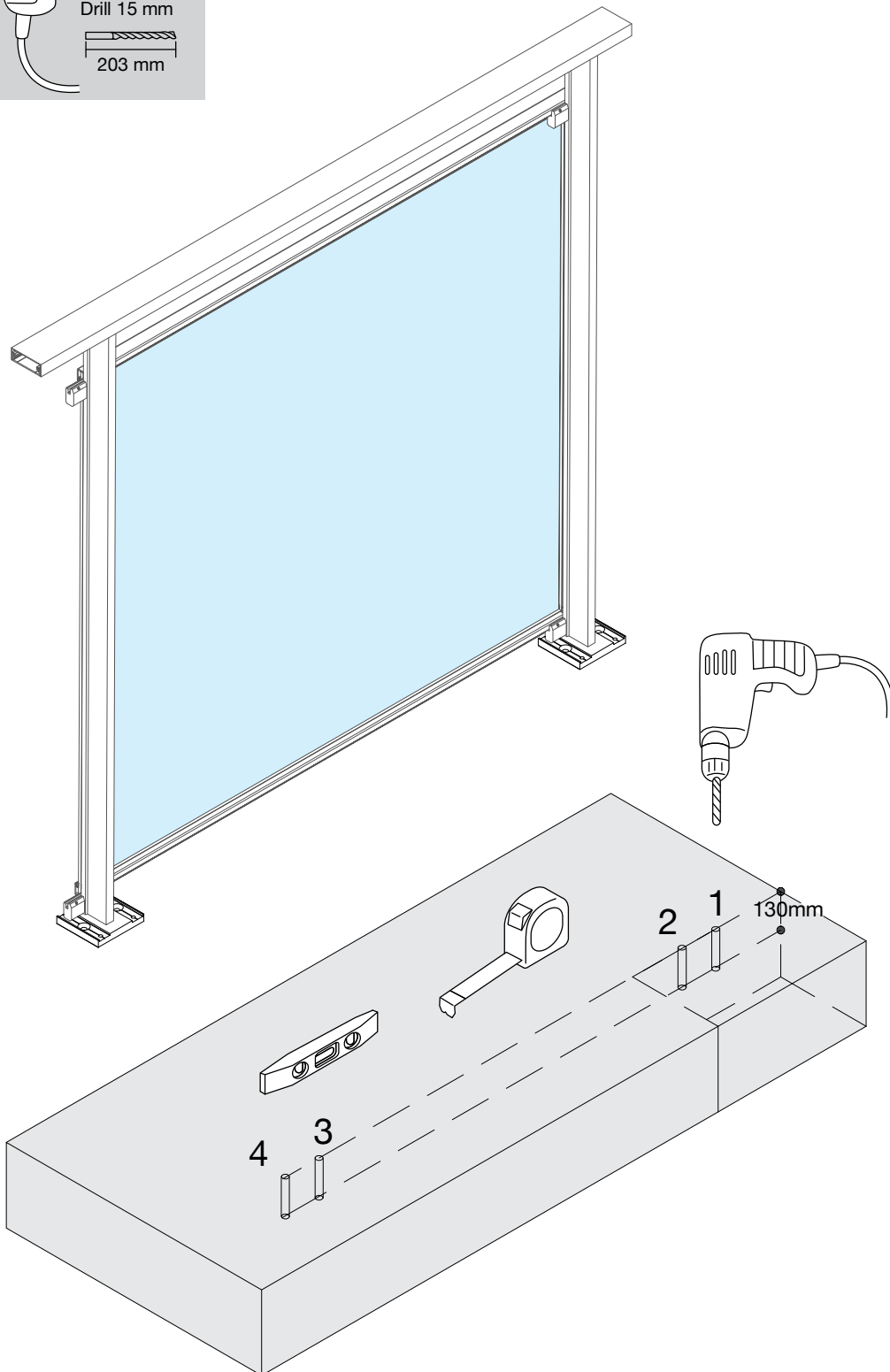
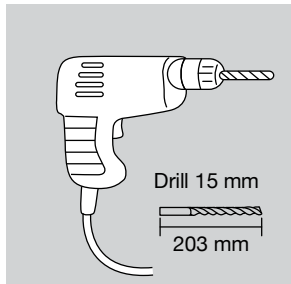

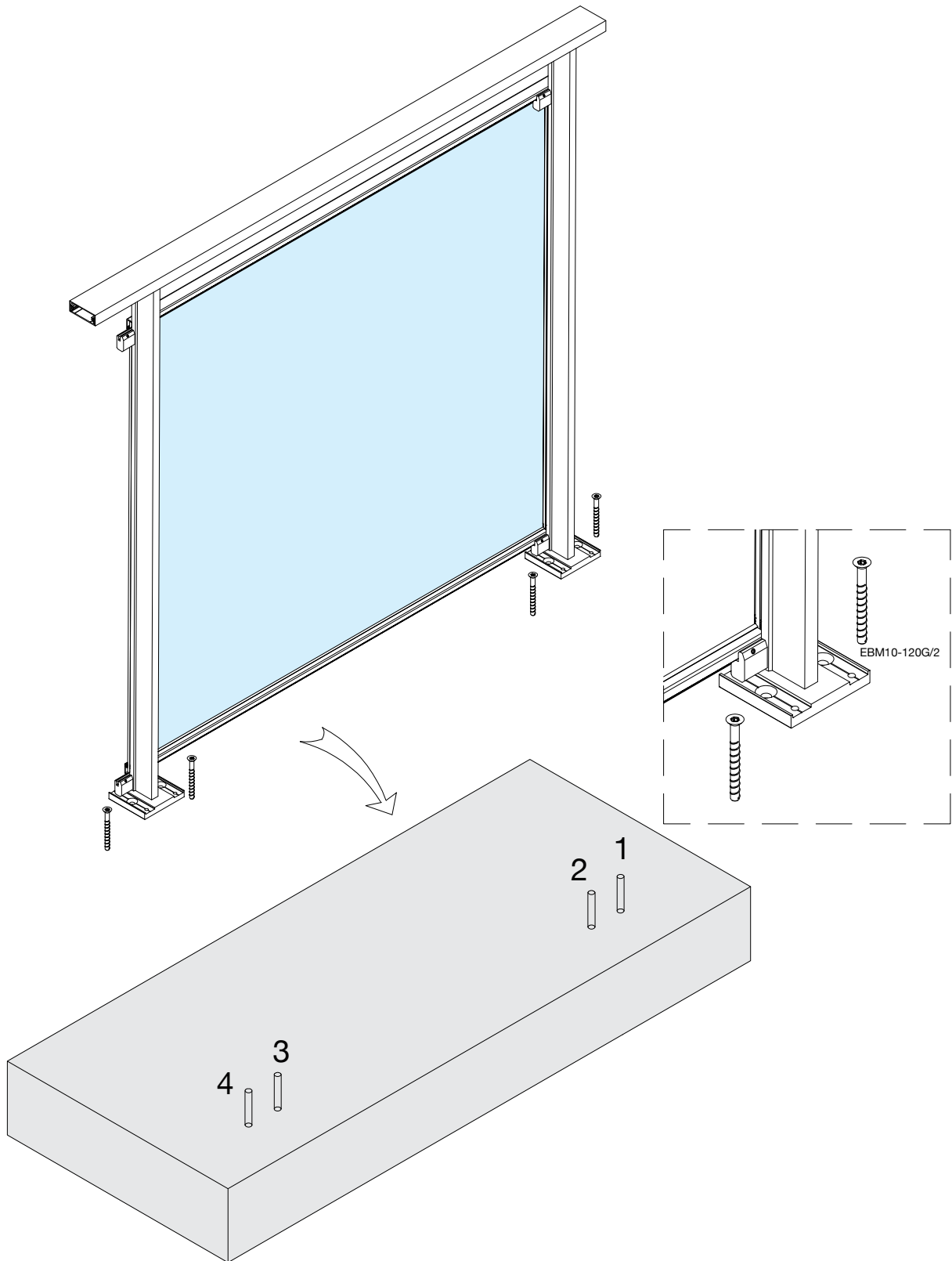

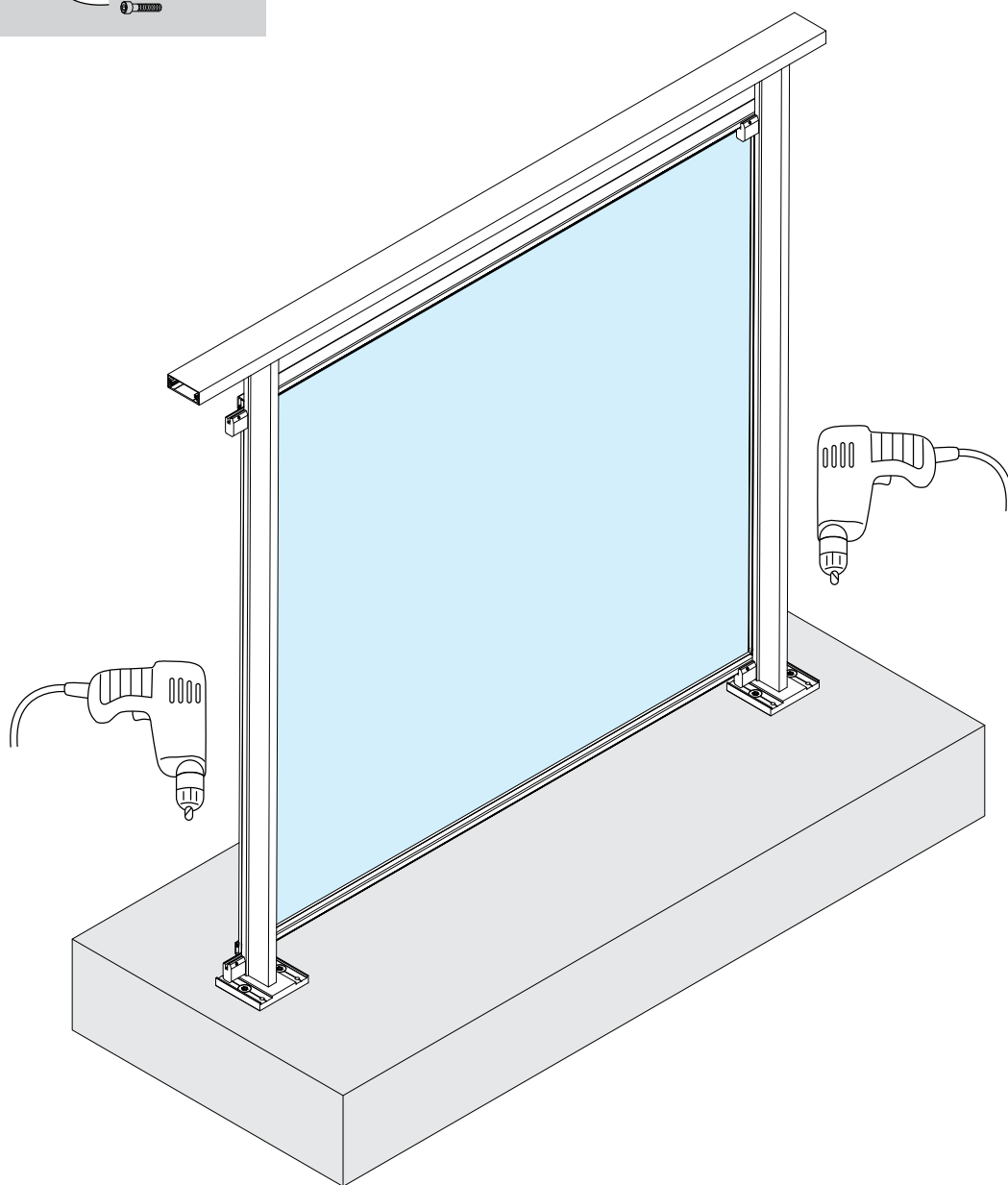
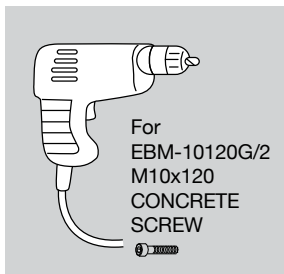

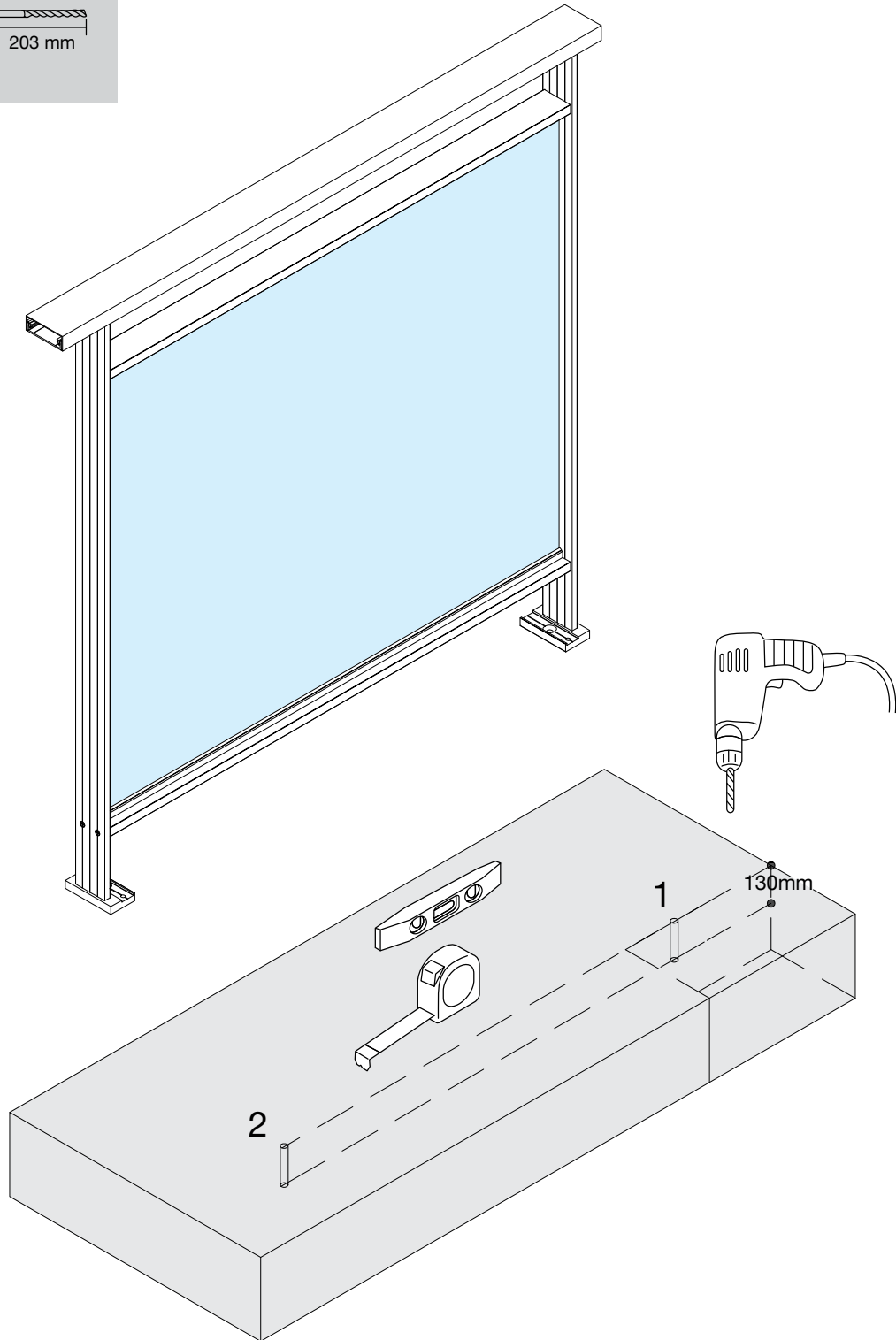
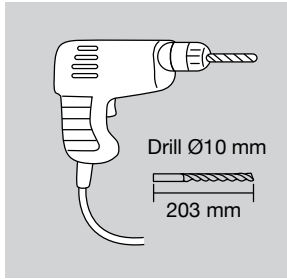

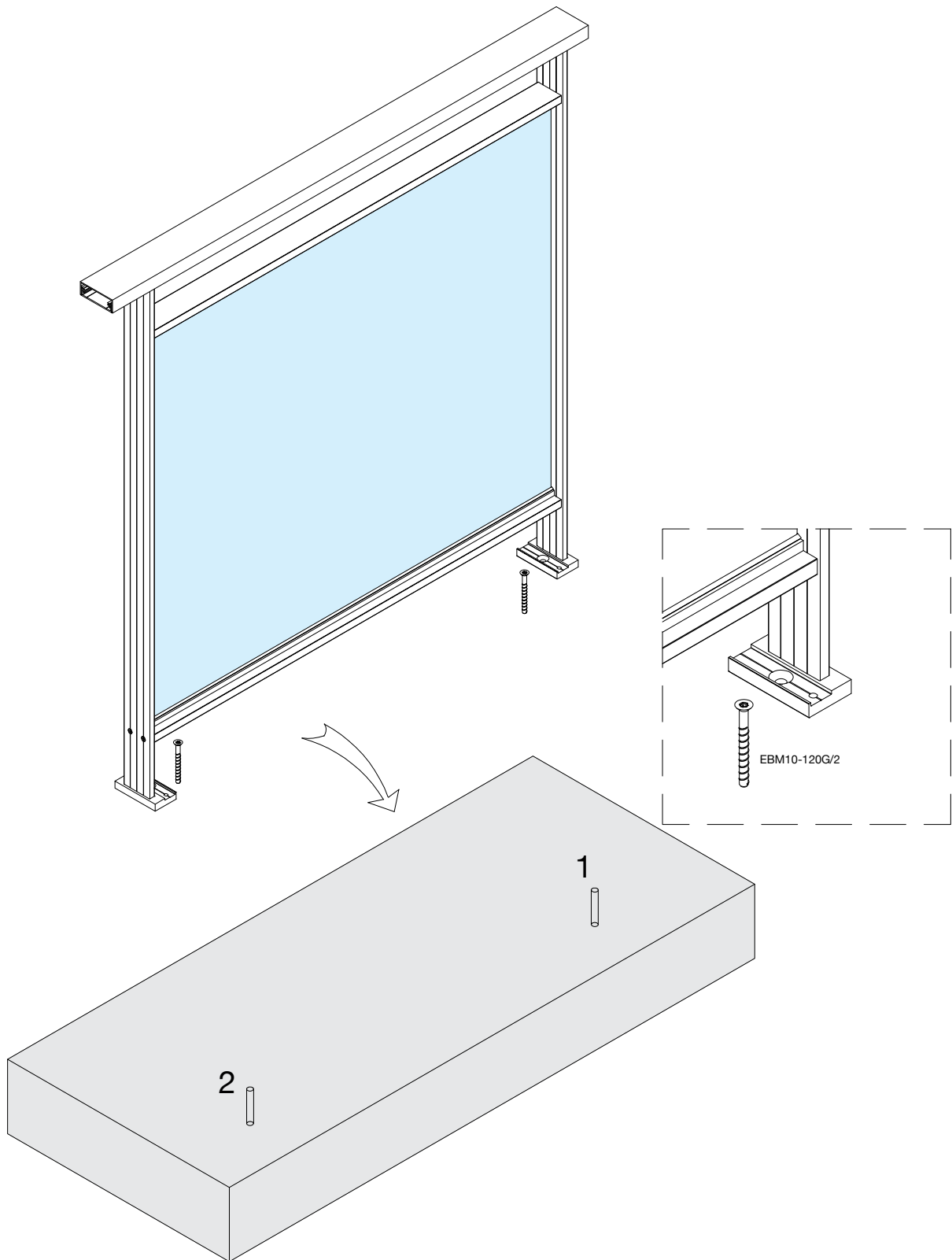

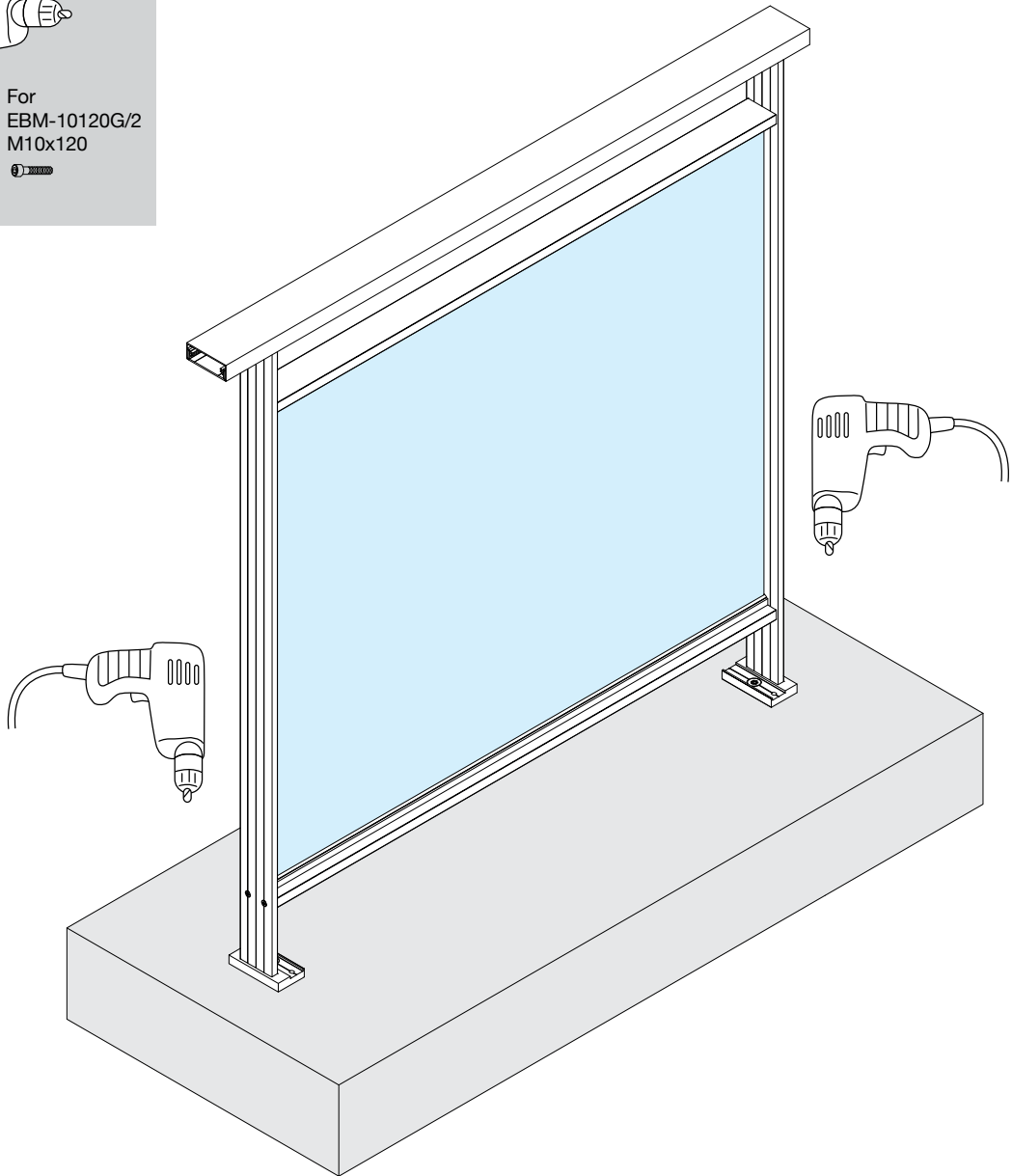

Synthesis Profiles & Accessories



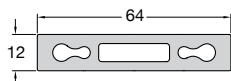

Κωδικός / Code: **FSN-100**

ΒΑΡΟΣ / WEIGHT: 1442 gr/m

ΚΟΛΩΝΑ 12x64

COLUMN 12x64

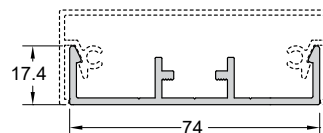

Κωδικός / Code: **CLS-201**

ΒΑΡΟΣ / WEIGHT: 1442 gr/m

ΒΑΣΗ ΚΟΥΠΑΣΤΗΣ FSN-221/222

BASE FOR HANDRAIL FSN-221/222

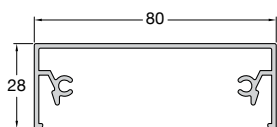

Κωδικός / Code: **FSN-221**

ΒΑΡΟΣ / WEIGHT: 754 gr/m

ΚΑΠΑΚΙ ΚΟΥΠΑΣΤΗΣ 80X28

COVER FOR HANDRAIL 80X28

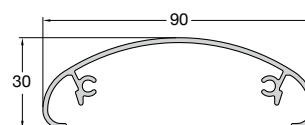

Κωδικός / Code: **FSN-222**

ΒΑΡΟΣ / WEIGHT: 736 gr/m

ΚΑΠΑΚΙ ΟΒΑΛ ΚΟΥΠΑΣΤΗΣ 90X30

COVER FOR HANDRAIL 90X30

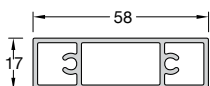

Κωδικός / Code: **FSN-302**

ΒΑΡΟΣ / WEIGHT: 781 gr/m

ΚΑΡΕ 58x17

SQUARE 58x17

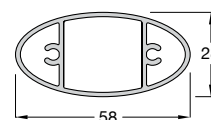

Κωδικός / Code: **FSN-304**

ΒΑΡΟΣ / WEIGHT: 804 gr/m

ΠΡΟΦΙΛ ΟΒΑΛ 58x28

PROFILE OVAL 58X28

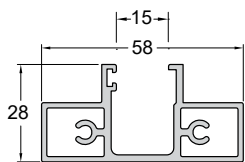

Κωδικός / Code: **FSN-303**

ΒΑΡΟΣ / WEIGHT: 976 gr/m
 ΟΔΗΓΟΣ ΤΖΑΜΙΟΥ 58x28
 GUIDE FOR GLASS 58x28

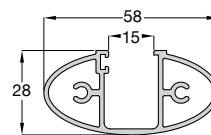

Κωδικός / Code: **FSN-306**

ΒΑΡΟΣ / WEIGHT: 976 gr/m
 ΟΔΗΓΟΣ ΤΖΑΜΙΟΥ ΟΒΑΛ
 GUIDE OVAL FOR GLASS

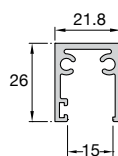

Κωδικός / Code: **FSN-307**

ΒΑΡΟΣ / WEIGHT: 475 gr/m
 ΟΔΗΓΟΣ ΤΖΑΜΙΟΥ 21.8x26
 GUIDE FOR GLASS 21.8x26

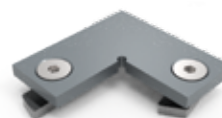

Κωδικός / Code: **4289**

ΓΩΝΙΑΚΟΣ ΣΥΝΔΕΣΜΟΣ 90° ΓΙΑ ΚΟΥΠΑΣΤΗ CLS-201
 CORNER CONNECTOR 90° FOR HANDRAIL CLS-201



Κωδικός / Code: **4275**

ΣΥΝΔΕΣΜΟΣ ΕΣΩΤΕΡΙΚΟΥ ΟΔΗΓΟΥ CLS-302 ΕΥΘΕΙΑ
 CONNECTOR FOR GUIDE CLS-302



Κωδικός / Code: **4712**

ΠΕΛΜΑ ΚΟΛΩΝΑΣ FSN-100
 SUPPORT FOOT FOR COLUMN FSN-100

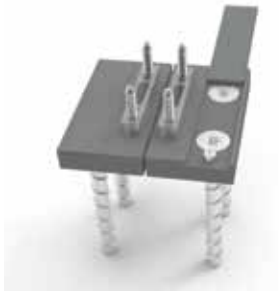

Κωδικός / Code: **4732**
 ΠΕΛΜΑ ΚΟΛΩΝΑΣ FSN-100
 SUPPORT FOOT FOR COLUMN FSN-100

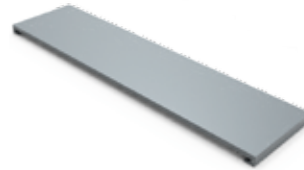

Κωδικός / Code: **E4710**
 ΚΑΠΑΚΙ ΠΕΛΜΑΤΟΣ 4712
 FOOT COVER FOR 4712



Κωδικός / Code: **4922**
 ΤΑΠΑ ΚΟΥΠΑΣΤΗΣ FSN-221
 END CAP FOR HANDRAIL FSN-221



Κωδικός / Code: **4921**
 ΤΑΠΑ ΚΟΥΠΑΣΤΗΣ FSN-222
 END CAP FOR HANDRAIL FSN-222



Κωδικός / Code: **4270**
 ΣΥΝΔΕΣΜΟΣ CLS-201/301/302/305
 CONNECTOR FOR CLS-201/301/302/305

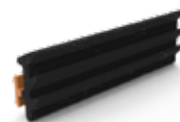

Κωδικός / Code: **4912**
 ΛΑΣΤΙΧΟ ΣΦΗΝΑ
 GLAZING GASKET



Κωδικός / Code: **US530-2/3/4 PRM**

ΛΑΣΤΙΧΟ ΣΦΗΝΑ
GLAZING GASKET



Κωδικός / Code: **UA410-420M**

ΛΑΣΤΙΧΟ ΣΦΗΝΑ 1 MM
GLAZING GASKET 1 MM

Πάκτωση των πελμάτων στο μπετόν (ελάχιστες απαιτήσεις)
Ground anchoring of support feet (minimum requirements)

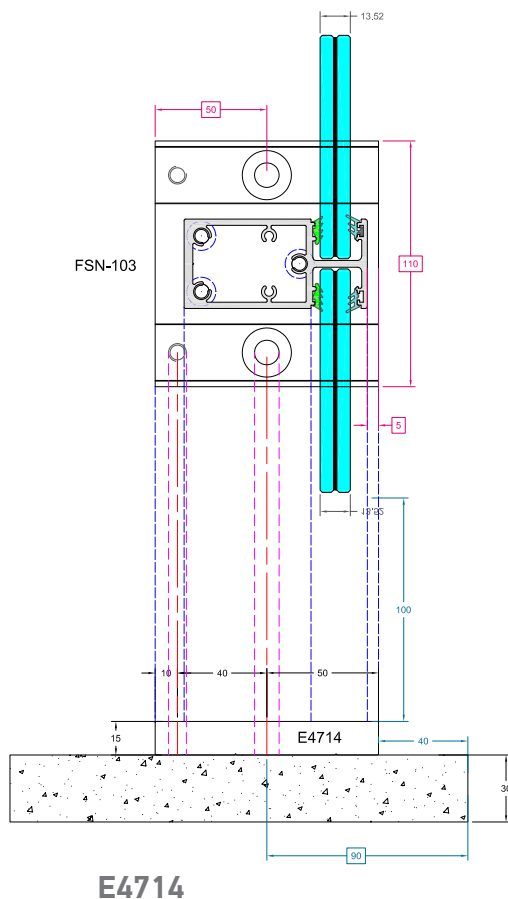
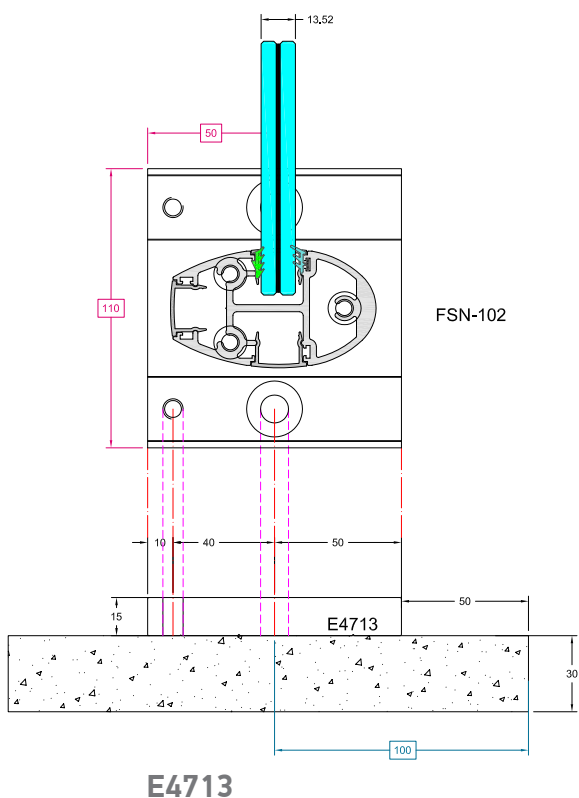
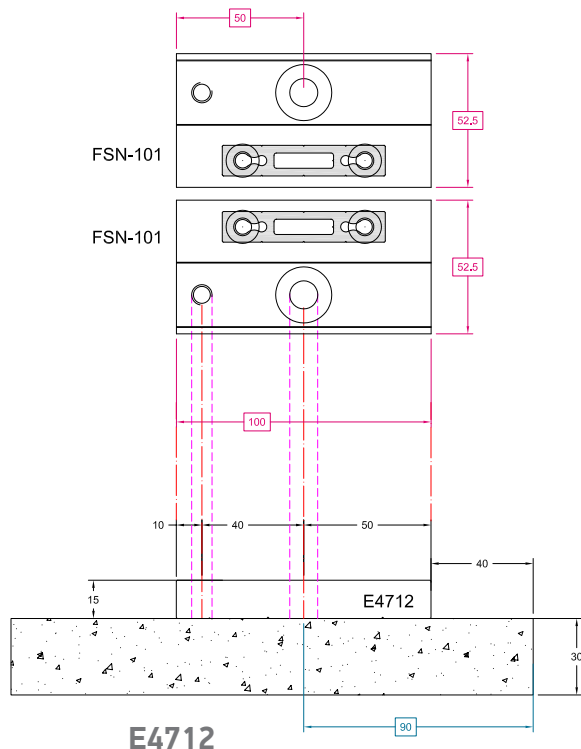
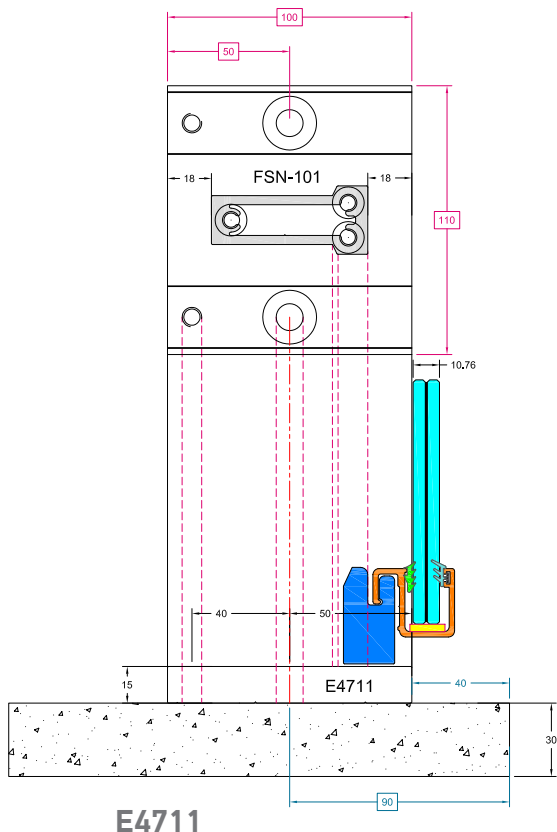

Μέγιστη εισχώρηση του υαλοπίνακα στα προφίλ Fusion Orbit-01/-02 FSN-102 / 103 / 104 θα είναι μέχρι 15mm. /
 Maximum glass Insertion into Fusion Orbit-01/-02 profiles FSN-102 / 103 / 104 would be 15mm.

E4715

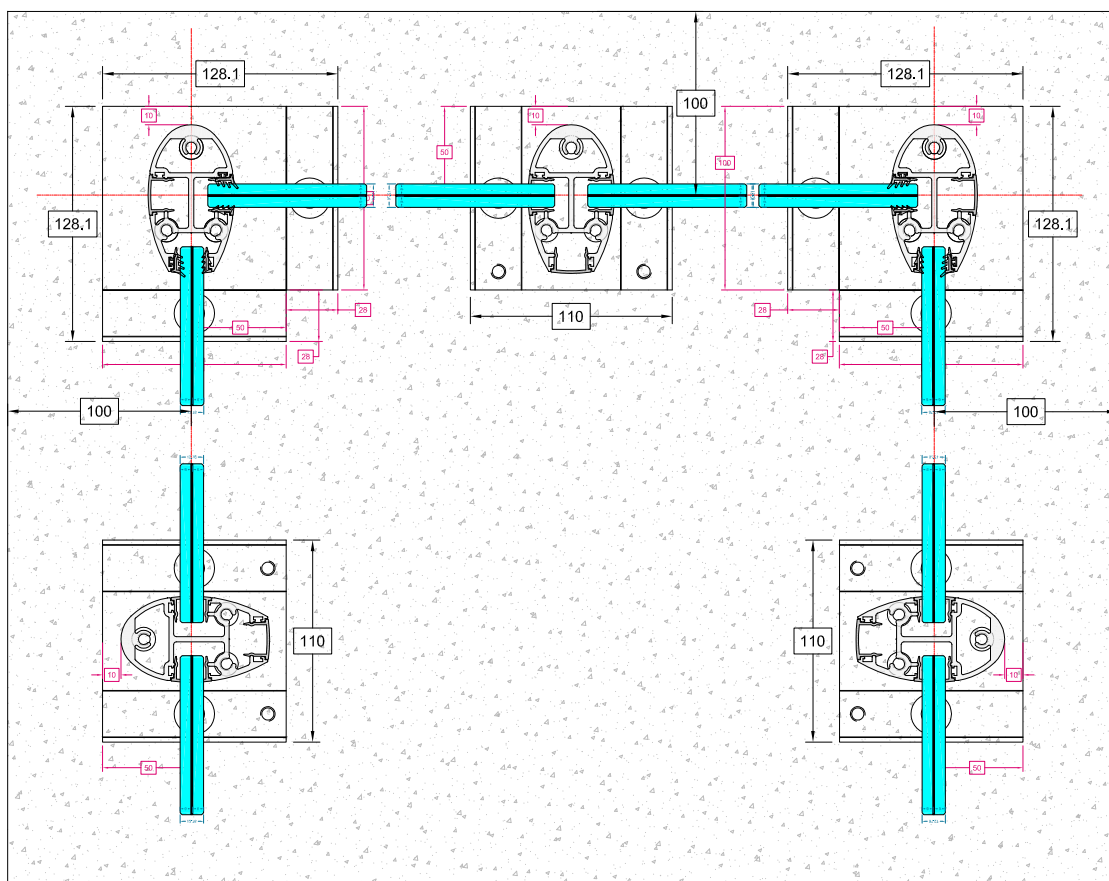
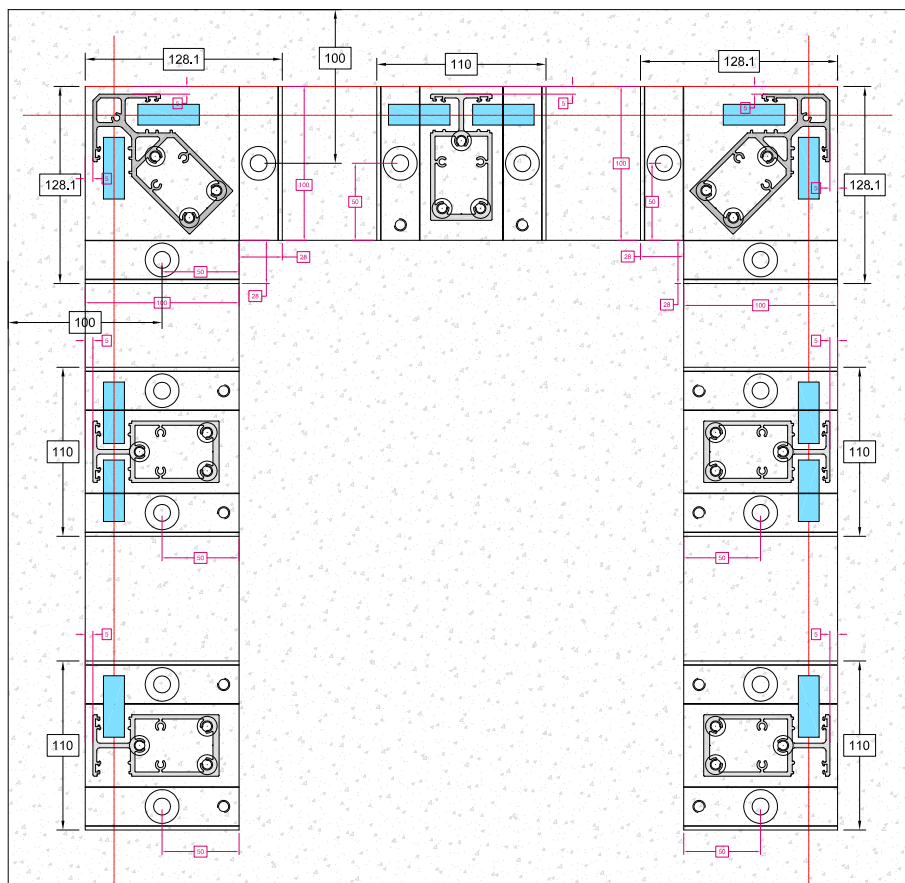

E4716

Σύνδεση κουπαστών στον τοίχο με τα εξαρτήματά τους / Wall fixing Fusion rail tops with their accessories

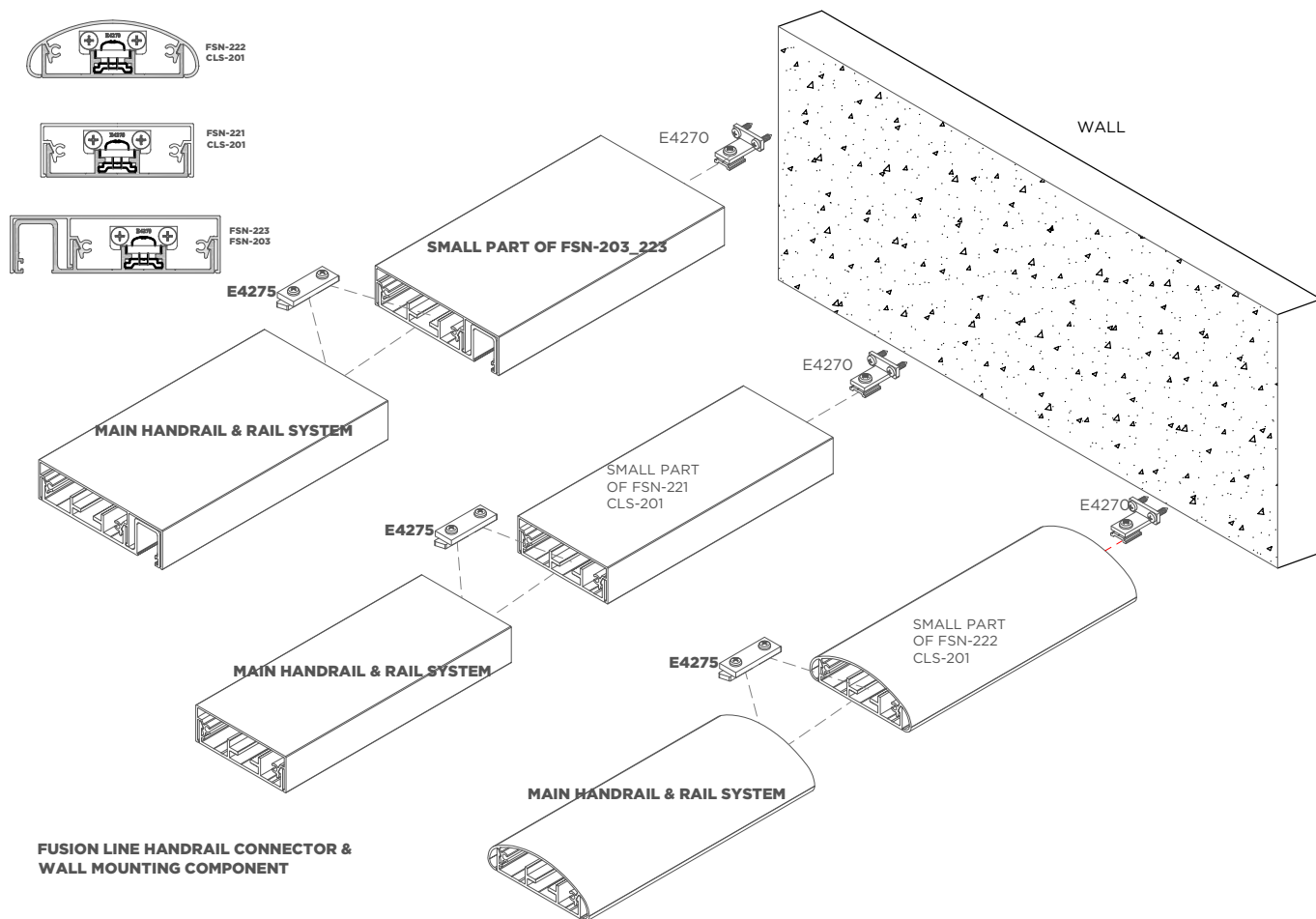

Αγκύρια στερέωσης / Concrete anchors



Κωδικός / Code: **EB7991-1070**
 ΒΙΔΑ ΑΛΛΕΝ INOX DIN7991 M10X70
 INOX ALLEN SCREW DIN7991 M10X70



Κωδικός / Code: **EB01M-1060**
 ΕΚΤΟΝΟΥΜΕΝΟ ΜΕΤΑΛΙΚΟ ΟΥΠΑ
 EXPANSION PLUG



Κωδικός / Code: **EBM-10120G/2**
 ΤΣΙΜΕΝΤΟΒΙΔΑ ΦΡΕΖΑΤΗ 10X120 ΑΛΛΕΝ
 ALLEN TORX CONCRETE SCREW 10X120



Κωδικός / Code: **EBM-75092G**
 ΜΠΕΤΟΒΙΔΑ ΦΡΕΖΑΤΗ TORX
 TORX CONCRETE SCREW



Κωδικός / Code: **EBM-75112G**
 ΜΠΕΤΟΒΙΔΑ ΦΡΕΖΑΤΗ TORX
 TORX CONCRETE SCREW

REQUIRED TOOLS

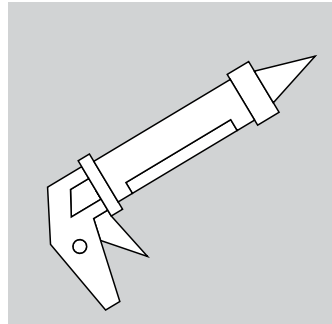
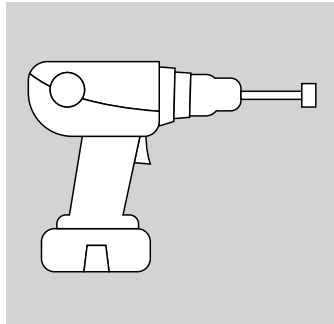
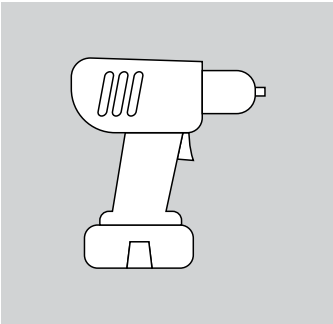
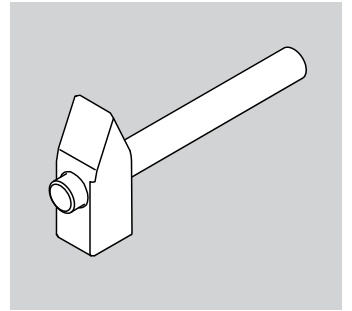
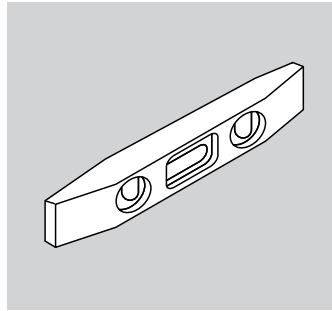
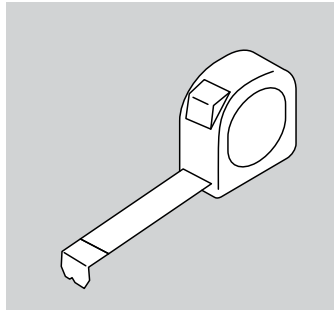
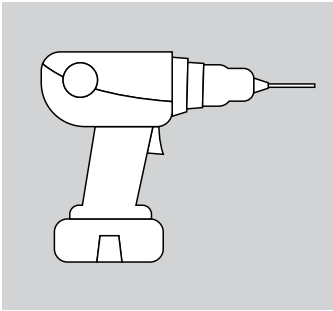



320 11 Inofita Viotia, Greece

T. +30 22620 47000

F. +30 22620 47090

www.aluminco.com